



## Pneumatic Cylinders

E.MC has been creating, developing and continuously improving the quality and design of your pneumatic cylinders for over 20 years. The extensive technical research team at E.MC continues to strive for improved methods and technologies. Our manufacturing facilities operate seamlessly with quality testing and monitoring at the top priority. The 3-point positioning system used to precisely machine head caps and pistons utilizes cutting edge 3D CNC machining.

As a global distributor of high end pneumatics, our products provide the solutions you need for your most challenging projects.

At E.MC we're committed to excellence, precision and ongoing development. Let us take you from 'Good to Great'.



## ☉ Installation and Use

1. To ensure the component has not been damaged during transport please inspect the device prior to
2. Confirm the pneumatic cylinder selected aligns with the loader.
3. If using a pneumatic cylinder supporting high temperatures or cold environments, utilize anti-freezing accessories.
4. Before connecting tubing to your pneumatic cylinder, make sure all lines are clean and free of debris. We your working medium with a minimum 25um filtration prior to installation.
5. Applying lateral load may limit the life cycle of your pneumatic cylinder if not installed properly. Please ensure a clean, level surface.
6. If storing your pneumatic cylinder for future use, always ensure the device is treated with an anti-rust ports covered.

## ☉ Attention Points

1. Place filter near the direction control valve to remove any possible iron rust, particles or water which may the tube.
2. When using your cylinder in corrosive environments always use appropriate tubing materials in conjunction
3. Ensure the cross section of tube between the cylinder and directional control valve has the appropriate stated piston speed.
4. Remove all particulates, iron rust etc. prior to installation or repair.
5. Always use appropriate seals and lubricants to connect your component.
6. Piston rods should be chosen for use based on actual load. Varying load rates may adversely affect the component.

## ☉ After Use

1. When installing the cylinder in temperatures below 5°C or above 60°C, use the appropriate sealing tape etc.
2. If using pneumatic cylinders in corrosive or dangerous environments, take appropriate protective you contact us if you intended use extends into harsh environments.
3. The compressed air entering the component but be free of particles and moisture.
4. The air cushion is designed to absorb the impact of the piston at the end of the stroke.
5. The cushion positioning is pre-set with your device. Adjusting the cushion can be done by adjusting the right to strengthen the buffer, or left to weaken it.
6. For best results avoid using the pneumatic cylinder directly under cutting compounds, refrigerants, rust and

## ☉ Please Note

1. Always use the correct cylinder for the appropriate amount of force for your objective.
2. Applying excessive force causing damage to the cylinder barrel may create scaring within the barrel resulting in poor performance.
3. Please ensure you are installing your cylinder on a level surface to avoid shifting which could result in poor performance of your component.
4. Always use the appropriate cylinder for your specific project. Installing the incorrect cylinder for your project can result in damage to your device.

# General Information About Pneumatic Cylinder



## Air Cylinder Theory – Force Table

Bore Size(mm)	8		10		12		16		20		25		
OD of rod(mm)	4		4		6		6		8		10		
Acting type	Double acting		Double acting		Double acting		Double acting		Double acting		Double acting		
	Push force	Pull force	Push force	Pull force	Push force	Pull force	Push force	Pull force	Push force	Pull force	Push force	Pull force	
Actual working area (mm <sup>2</sup> )	50.2	37.7	78.5	65.9	113	84.8	201	172.7	314	263.8	490.6	412.1	
Working pressure (Mpa)	0.1	5.02	3.77	7.85	6.59	11.30	8.48	20.10	17.27	31.40	26.38	49.06	41.21
	0.2	10.04	7.54	15.70	13.18	22.60	16.96	40.20	34.54	62.80	52.76	98.12	82.42
	0.3	15.06	11.31	23.55	19.77	33.90	25.44	60.30	51.81	94.20	79.14	147.18	123.63
	0.4	20.08	15.08	31.40	26.36	45.20	33.92	80.40	69.08	125.60	105.52	196.24	164.84
	0.5	25.10	18.85	39.25	32.95	56.50	42.40	100.50	86.35	157.00	131.90	245.30	206.05
	0.6	30.12	22.62	47.10	39.54	67.80	50.88	120.60	103.62	188.40	158.28	294.36	247.26
	0.7	35.14	26.39	54.95	46.13	79.10	59.36	140.70	120.89	219.80	184.66	343.42	288.47
	0.8	40.16	30.16	62.80	52.72	90.40	67.84	160.80	138.16	251.20	211.04	392.48	329.68
	0.9	45.18	33.93	70.65	59.31	101.70	76.32	180.90	155.43	282.60	237.42	441.54	370.89

## Air Cylinder Theory – Force Table

$$F = P \times A$$

Actual piston working area ( mm<sup>2</sup> )  
Working pressure (Mpa)  
Theoretical force of cylinder (N)

## Air Cylinder Theory – Force Table

Bore Size(mm)	32		40		50		63		80		100		125		160		200		
OD of rod(mm)	12		16		20		20		25		25		32		40		40		
Acting type	Double acting		Double acting		Double acting		Double acting		Double acting		Double acting		Double acting		Double acting		Double acting		
	Push force	Pull force	Push force	Pull force	Push force	Pull force	Push force	Pull force	Push force	Pull force	Push force	Pull force	Push force	Pull force	Push force	Pull force	Push force	Pull force	
Actual working area (mm <sup>2</sup> )	804	690	1256	1055	1963	1649	3117	2803	5026	4536	7853	7362	12272	11468	20106	18849	31416	30157	
Working pressure (Mpa)	0.1	80.4	69.0	125.6	105.5	196.3	164.9	311.7	280.3	502.6	453.6	785.3	736.2	1227.2	1146.8	2010.6	1884.9	3141.6	3015.7
	0.2	160.8	138.0	251.2	211.0	392.6	329.8	623.4	560.6	1005.2	907.2	1570.6	1472.4	2454.4	2293.6	4021.2	3769.8	6283.2	6031.4
	0.3	241.2	207.0	376.8	316.5	588.9	494.7	935.1	840.9	1507.8	1360.8	2355.9	2208.6	3681.6	3440.4	6031.8	5654.7	9424.8	9047.1
	0.4	321.6	276.0	502.4	422.0	785.2	659.6	1246.8	1121.2	2010.4	1814.4	3141.2	2944.8	4908.8	4587.2	8042.4	7539.6	12566.4	12062.8
	0.5	402.0	345.0	628.0	527.5	981.5	824.5	1558.5	1401.5	2513.0	2268.0	3926.5	3681.0	6136.0	5734.0	10053.0	9424.5	15708.0	15078.5
	0.6	482.4	414.0	753.6	633.0	1177.8	989.4	1870.2	1681.8	3015.6	2721.6	4711.8	4417.2	7363.2	6880.8	12063.6	11309.4	18849.6	18094.2
	0.7	562.8	483.0	879.2	738.5	1374.1	1154.3	2181.9	1962.1	3518.2	3175.2	5497.1	5153.4	8590.4	8027.6	14074.2	13194.3	21991.2	21109.9
	0.8	643.2	552.0	1004.8	844.0	1570.4	1319.2	2493.6	2242.4	4020.8	3628.8	6282.4	5889.6	9817.6	9174.4	16084.8	15079.2	25132.8	24125.6
	0.9	723.6	621.0	1130.4	949.5	1766.7	1484.1	2805.3	2522.7	4523.4	4082.4	7067.7	6625.8	11044.8	10321.2	18095.4	16964.1	28274.4	27141.3

## Product Selection

### 1、Confirm the internal diameter of the cylinder

- ① Axial load thrust of the cylinder shall be confirmed according to actual load situation of the required cylinder;
- ② Load rate  $\eta$  of the cylinder shall be confirmed according to the action situation of the load;  
Load rate has relationship with action speed of the cylinder, which is generally recommended as:  
Under static load or low speed:  $\eta \leq 0.7$   
Speed 50~50mm /s:  $\eta \leq 0.5$   
When speed  $>500$ mm /s:  $\eta \leq 0.3$
- ③ Working pressure of the cylinder shall be confirmed according to the condition of air supply.

### 2、Confirm the cylinder stroke

The stroke of cylinder is pre-selected according to the ratio of cylinder operation distance and stroke of transmission mechanism.  
To facilitate installing and debugging, there shall be proper allowance left for the stroke calculated. Standard strokes guaranteed with quick supply are advised to be chosen as possible as one can, which can help to cut down your cost.

### 3、Confirm the cylinder type

The type of the cylinder shall be selected according to the specific requirements of application and installation of the cylinder.

### 4、Selection of buffer way of the cylinder

There are different buffer devices equipped to the cylinders made by our company. Customer shall choose them according to the action situation of actual load. If both of the load and speed are higher, it is difficult to absorb the impact only by the buffer of the cylinder itself. Therefore, buffer circuit must be designed or use external buffer to release the impact.

### 5、Confirm whether the cylinder has magnet

Whether the cylinder has sensor switch shall be confirmed according to the actual situation. And relative magnetic switch shall be chosen to use together.

### 6、Selection of installation mode of the cylinder

Installation mode of the cylinder shall be selected according to the application and installation requirements of the cylinder.

### 7、Selection of connecting mode of piston rod of the cylinder

After the cylinder is pre-selected, it is necessary to check the stability of piston rod (especially the piston is thinner, longer and larger) of the cylinder according to different installation modes and the air consumption under actual application condition shall be checked.

## Maintenance and Service

- 1、Maintenance should be done under safety condition, please turn off the power and air source first; making sure there is no air leaving in the tube;
- 2、Before attaching/removing rod end attachments, the cylinder must be fully retracted. The rod should never be pulled out, or be rotated when attaching/removing the rod end attachments. The rod end attachment should be screwed tightly on the rod end, with balanced locking force. Before usage, make sure no interference is present by manually checking the cylinder and attachment. After that, air can be supplied to the cylinder for use;
- 3、There should be no damage in the sliding parts between the cylinder and piston rod to prevent the air leakage caused by poor action of the cylinder and damage of seal parts of piston rod;
- 4、If the cylinder is not used for a long time, it shall be regularly actuated and shall be coated with oil to prevent it get rusted;
- 5、Please read the relevant content in this manual for the requirement of the cylinder about the air quality, application condition, tube connection and cylinder lubrication.

## Debugging

- 1、Speed control valve shall be installed at the two sides of the cylinder.
  - Check valve shall be opened gradually from completely closed state when the cylinder is debugged and the drive speed of the cylinder shall be gradually and slowly adjusted to the required speed.
  - There are two ways for installing check valve, including exhaust throttle and inlet throttle. Exhaust throttle is mostly adopted in pneumatic system because the cylinder will produce back pressure during work through exhaust throttle and ensuring relatively stable moving speed or speed adjustment, which will help avoid impact on cylinder cover caused by sudden and quick propulsion of piston rod when starting.
- 2、When the cylinder with buffer function is debugged, according to the load and speed, the flow control valve mounted on the cylinder cover shall be adjusted gradually from low to high level to ensure the cylinder will have no rebounding. What shall be noticed is not to adjust the buffer to the end state in debugging the stroke, otherwise there will be poor buffer or damage of seals caused by piston under high-speed situation.

## Installation and Use

- 1、 Prevent debris and dirt and other impurities into the cylinder before connect with pipe. 1~1.5 thread pitch should be reserved for wrapping tape. Don't wrap the tape around .

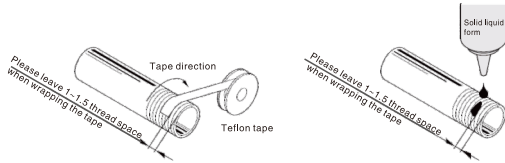

- 2、 To avoid overusing or inflowing of the liquid glue into the body when using liquid fixing glue (anaerobic adhesive) to lock the fitting, or it will get the parts stuck, leading not good performance.

- 3、 The axes of piston rod shall corresponde with the moving direction of load (coaxial). Piston rod and cylinder will produce opposite force which can easily damage the internal. The internal surface of the cylinder, guide sleeve, the surface of piston rod and seals.

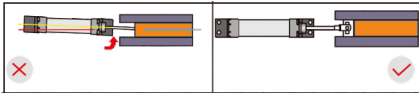

- 4、 Avoid direct connection of piston rod, or it will suffer vertical gravity: it shall add idler wheels under the load bottom to support the guide rail (as in below right photo). It is wrong installation as in below left photo, because the piston rod and cylinder will produce opposite force which can easily bend piston rod and damage the internal surface of the cylinder, guide sleeve, the surface of piston rod and seals.

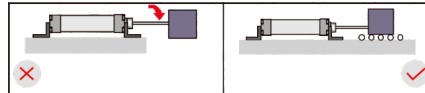

- 5、 Avoid direct connection of piston rod, or it will suffer vertical gravity: it shall add idler wheels under the load bottom to support the guide rail (as in below right photo). It is wrong installation as in below left photo, because the piston rod and cylinder will produce opposite force which can easily bend piston rod and damage the internal surface of the cylinder, guide sleeve, the surface of piston rod and seals.

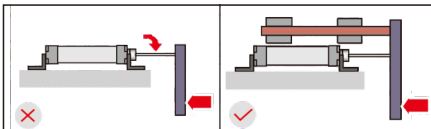

- 6、 To prevent that back activity hinge is far from force supply point, the piston rod will be influenced by torque force. To use middle action support to shorten the long distance between support point and force supply point.

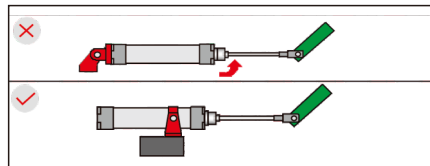

- 7、 Long-stroke cylinder shall set middle guide support to prevent natural drop of piston rod and to prevent the damage on piston rod caused by the droop of piston rod, bend of the cylinder, vibration and external load.

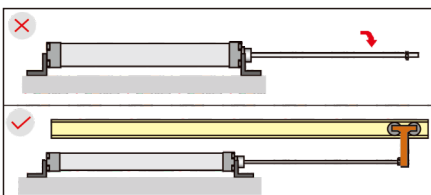

- 8、 It tends to bend at long stroke, thus the installation bracket shall be moved to the front cover.

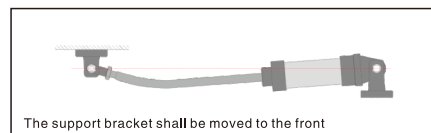

- 9、 The fixed cylinder shall not be connected with the rocker carrying out circular action (fixed with LB). At this time, it shall be connected with swing cylinder (fixed with CA/ CB/TC )

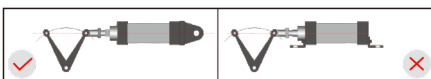

## Installation and Use

10. If the height (H) between installation surface of bearing bracket and the position of bearing is too great, when cylinder works, the installation part of the support will produce great torque force, Which may cause damage to installing bolt and other parts.

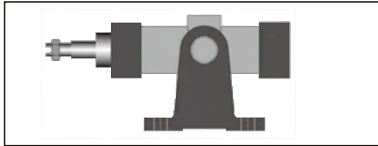

11. Proper installation shall be adopted considering the direction of load (flange type installation).

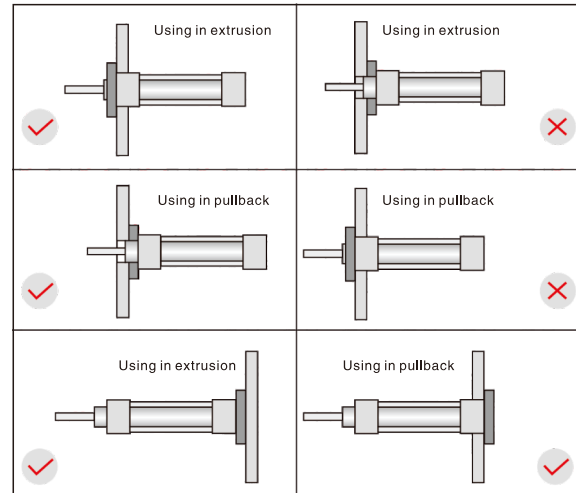

## SG

### Compact Guide Cylinder

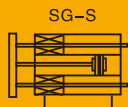

#### Specifications



Bore(mm)	6	10	12	16	20	25	32	40	50	63
Acting type	Double acting									
Working medium	Clean Air(after 40 μm filtration)									
Working pressure (MPa)	0.1~1.0									
Guaranteed pressure (MPa)	1.5									
Working temperature (°C)	-20~80( No freezing)									
Piston speed (mm/s)	30~500									
Cushion	Rubber cushion									
Stroke tolerance(mm)	$\begin{matrix} +1.0 \\ 0 \end{matrix}$									
No-rotating precision ★	SGL	—	± 0.08°	± 0.07°	± 0.06°	± 0.06°	± 0.05°			
	SGM	± 0.10°		± 0.09°	± 0.08°	± 0.08°	± 0.06°			
Port Size	M3 × 0.5		M5 × 0.8		G1/8 ①			G1/4 ①		

★ Retract position. ① PT、NPT port size is optional.

#### How to Order?

Series No	Type No	Type	Bore X	Stroke	Magnet No	Thread Type
SG	L: Linear bearing M: Slide bearing		6 10 12	25 50 75	S: With magnet	Blank: G P: PT T: NPT
	Blank: Standard type J: Adjuster type		...	...		

#### Order Example:

SG series, linear bearing, bore 16mm, stroke 30mm, EPR code is: SGL16X30-S

#### Optional Accessories

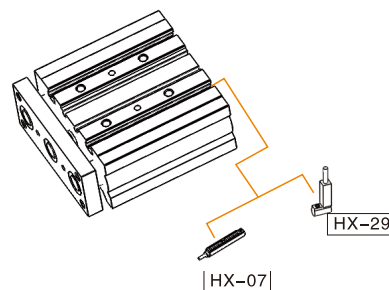

Note: Short stroke please use HX-29 series due to limited space.

#### Stroke

Bore (mm)	Standard Stroke (mm)	Max. Stroke (mm)
6	5 10 15 20	20
10	5 10 15 20 25 30	30
12	10 20 25 30 40 50 60 70 75 80 90 100 125 150	150
16	10 20 25 30 40 50 60 70 75 80 90 100 125 150 175 200	200
20/25	20 25 30 40 50 60 70 75 80 90 100 125 150 175 200 225 250	250
32-63	25 30 40 50 60 70 75 80 90 100 125 150 175 200 225 250	250

Note: Above chart shows standard stroke, for unstandard stroke, please contact with us.

#### How to Mount ?

Fixation of screw on top surface

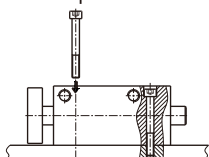

Fixation of screw at bottom surface

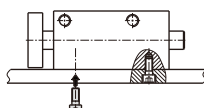

Fixation of screw at back surface

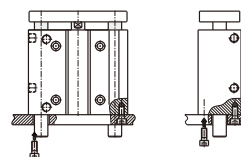

Fixation of T slot at bottom

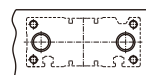
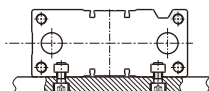



# SG Series Compact Guide Cylinder



## Main Dimension

### SG12~63

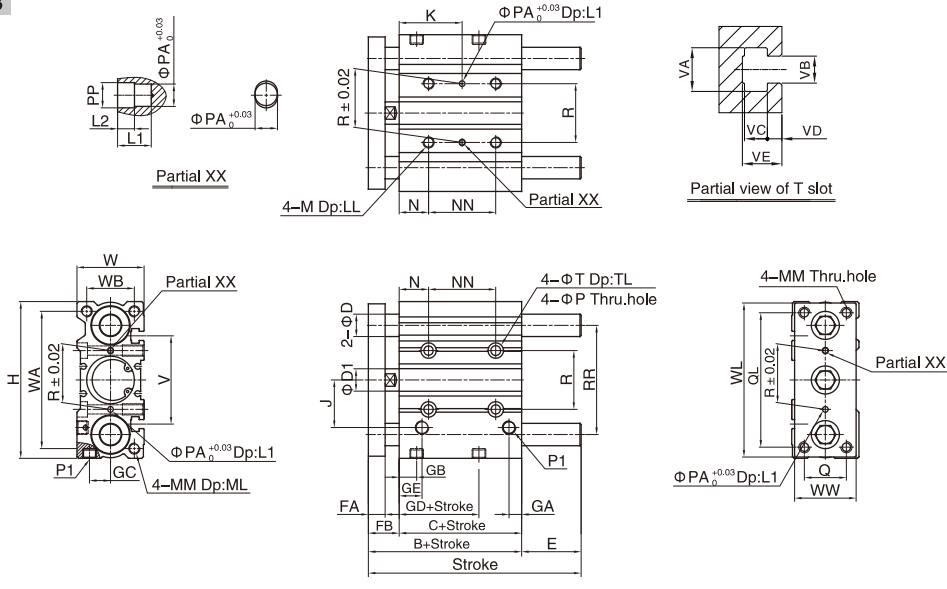

(mm)

Bore\Sign	E(SGL)				E(SGM)				NN				K								
	≤30	31-100	101-200	>200	≤50	51-100	101-200	>200	≤30	31-100	101-200	>200	≤30	31-100	101-200	>200					
12	0	13	43	-	0	13	43	-	20	40	110	-	15	25	60	-					
16	0	19	49	-	0	19	49	-	24	44	110	-	17	27	60	-					
20	0	27	51	69	0	27	51	69	24	44	120	200	29	39	77	117					
25	0	28.5	51	68.5	0	28.5	51	68.5	24	44	120	200	29	39	77	117					
Bore\Sign	≤50	51-100	101-200	>200	≤50	51-100	101-200	>200	≤40	41-100	101-200	>200	≤40	41-100	101-200	>200					
32	5.5	42.5	58.5	80.5	5.5	42.5	58.5	80.5	24	48	124	200	33	45	83	121					
40	0	36	52	74	0	36	52	74	24	48	124	200	34	46	84	122					
50	4	46	62	89	4	46	62	89	24	48	124	200	36	48	86	124					
63	0	41	57	84	0	41	57	84	28	52	128	200	38	50	88	124					
Bore\Sign	B	C	FA	FB	P1	GA	GB	GC	GD	GE	R	RR	N	P	PA	PP	T	TL	M	LL	D1
12	42	29	8	13	M5X0.8	7.5	11	8	13	11	23	41	5	4.2	3	3.5	8	4.5	M5X0.8	10	6
16	46	33	8	13	M5X0.8	8	11	10	15	11	24	46	5	4.2	3	3.5	8	4.5	M5X0.8	10	8
20	53	37	10	16	1/8"	9	10.5	10.5	12.5	10.5	28	54	17	5.2	3	3.5	9.5	5.5	M6X1.0	12	10
25	53.5	37.5	10	16	1/8"	9	11.5	13.5	12.5	11.5	34	64	17	5.2	4	4.5	9.5	5.5	M6X1.0	12	12
32	59.5	37.5	12	22	1/8"	9	12.5	15	7	12.5	42	78	21	6.9	4	4.5	11	7.5	M8X1.25	16	16
40	66	44	12	22	1/8"	10	14	18	13	14	50	86	22	6.9	4	4.5	11	7.5	M8X1.25	16	16
50	72	44	16	28	1/4"	11	12	21.5	9	14	66	110	24	8.7	5	6	14	9	M10X1.5	20	20
63	77	49	16	28	1/4"	13.5	16.5	28	14	16.5	80	124	24	8.7	5	6	14	9	M10X1.5	20	20
Bore\Sign	D(SGL)	D(SGM)	J	W	WA	WB	WL	WW	H	Q	QL	MM	ML	L1	L2	V	VA	VB	VC	VD	VE
12	6	8	18	26	50	18	56	22	58	14	48	M4X0.7	10	6	3	37	7.4	4.4	3.7	2	6.2
16	8	10	19	30	56	22	62	25	64	16	54	M5X0.8	12	6	3	38	7.4	4.4	3.7	2.5	6.7
20	10	12	25	36	72	24	81	30	83	18	70	M5X0.8	13	6	3	44	8.4	5.4	4.5	2.8	7.8
25	12	16	28.5	42	82	30	91	38	93	26	78	M6X1.0	15	6	3	50	8.4	5.4	4.5	3	8.2
32	16	20	34	48	98	34	110	44	112	30	96	M8X1.25	20	6	3	63	10.5	6.5	5.5	3.5	9.5
40	16	20	38	54	106	40	118	44	120	30	104	M8X1.25	20	6	3	72	10.5	6.5	5.5	4	11
50	20	25	47	64	130	46	146	60	148	40	130	M10X1.5	22	8	4	92	13.5	8.5	7.5	4.5	13.5
63	20	25	55	78	142	58	158	70	162	50	130	M10X1.5	22	8	4	110	17.8	11	10	7	18.5

### SGJ

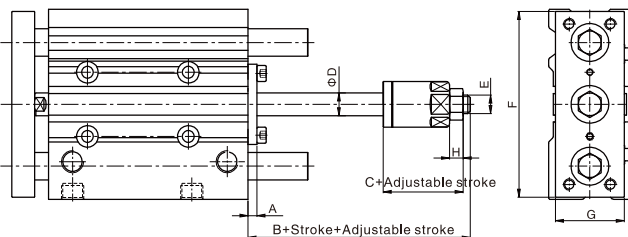

Bore\Sign	A	B	C	D	E	F	G	H
12	3	20	17	6	M5X0.5	56	22	4
16	3	24	21	8	M6X1.0	62	25	5
20	4	29	25	10	M8X1.25	81	30	6
25	5	32	29	12	M10X1.25	91	38	6
32	6	35	29	16	M14X1.5	110	44	8
40	6	35	29	16	M14X1.5	118	44	8
50	8	40	32	20	M18X1.5	146	60	11
63	8	40	32	20	M18X1.5	158	70	11

# EN Series Double Shaft Cylinder

## EN

### Double Shaft Cylinder

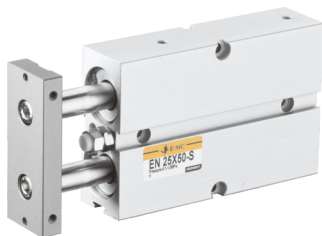
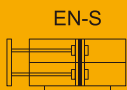

### Specifications

Bore(mm)	10	16	20	25	32
Acting type	Double acting				
Working medium	Clean Air(after 40 μ m filtration)				
Working pressure (MPa)	0.1~1.0				
Guaranteed pressure (MPa)	1.5				
Working temperature (°C)	-20~80( No freezing)				
Speed range (mm/s)	30~500				
Cushion type	Rubber cushion				
Stroke tolerance(mm)	+1.0 0				
Adjusting stroke (mm)	-8~0		-5~0		
No-return precision	± 0.4°		± 0.3°		
Port Size	M5 × 0.8				G1/8 ①

① PT、NPT port size is optional.

### How to Order?

Series No	Bore X	Stroke	Magnet No	Thread Type
EN	10 16 20 ... 32	25 50 75 ...	S : With magnet	Blank: G P : PT T : NPT

#### Order Example:

EN series double shaft cylinder, Bore 32mm, stroke 30mm, with magnet, PT thread. ERP code is: EN32X30-S-P

### Product Features

- \* Double shaft provide good anti-bend performance and guarantee long life cycle and correct direction
- \* Suitable slot is designed for manetic sensor and fixing
- \* Embedding mounting and no need other brackets, room saving
- \* Easy to assemble and easy to maintain

### Optional Accessories

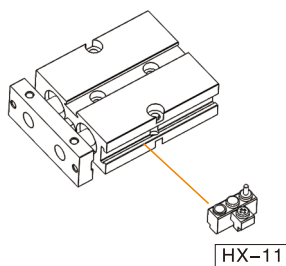

### Stroke

Bore (mm)	Standard Stroke (mm)	Max. Stroke (mm)
10	10 20 30 40 50 60 70 80 90 100	100
16~32	10 20 30 40 50 60 70 80 90 100 125 150 175 200	200

### Internal Structure

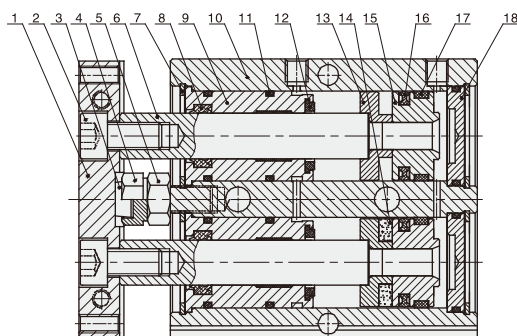

NO.	Part Name	Material
1	Fixing plate	Aluminum alloy
2	Nut	Carbon steel
3	Bumper	POM
4	Adjustable nut	Carbon steel
5	Screw	Carbon steel
6	Piston rod	S45C hard chrome carbon steel
7	C clip	Spring steel
8	Wiper seal	NBR
9	Head cover	Aluminum alloy
10	Body	Aluminum alloy
11	O-ring	NBR
12	Anti-bump cushion	TPU
13	Magnet holder	Aluminum alloy
14	Magnet	Plastic
15	Piston	Aluminum alloy
16	Piston seal	NBR
17	Wear ring	PTFE
18	Rear cover	Aluminum alloy



# EXS Series Double Shaft Cylinder



## EXS

### Double Shaft Cylinder



### Specifications

Bore(mm)	6	10	16	20	25	32
Acting type	Double acting					
Working Medium	Clean Air(after 40 μm filtration)					
Working Pressure (MPa)	0.1~1.0					
Guaranteed Pressure (MPa)	1.5					
Working Temperature (°C)	-20~80( No freezing)					
Speed range (mm/s)	30~500					
Cushion type	Rubber cushion					
Stroke tolerance(mm)	+1.0 0					
Adjustable stroke(mm)	-5~0					
No-rotating precision	± 0.2°	± 0.15°			± 0.1°	
Port Size	M5 × 0.8				G1/8 ①	

① PT、NPT port size is optional.

### How to Order?

Series No	Type No	Bore X	Stroke	Magnet No	Thread Type
EXS	M: Slide bearing	6 10 12 16 20 ...	25 50 75 ...	S : With magnet	Blank: G P : PT T : NPT

Order Example:

EXS series, Slide Bearing type, Bore 6mm, stroke 30mm ERP code is: EXSM6X30-S

Note: The cylinder's bore and stroke, mounting accessories details according to drawings.

### Optional Accessories

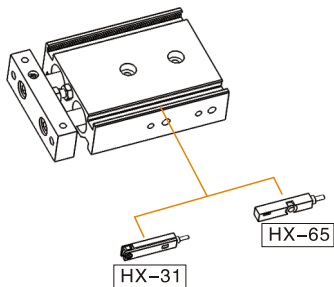

### Stroke

Bore (mm)	Standard Stroke (mm)	Max. Stroke (mm)
6	10 20 30 40 50	50
10	10 20 25 30 40 50 60 70 75 80 90 100	100
16-32	10 20 25 30 40 50 60 70 75 80 90 100 125 150 175 200	200

Note: The dimensions of non-std stroke cylinder has the same dimensions as the next longer stroke std. stroke cylinder.  
e.g. 27mm stroke cylinder has the same dimensions of 30 std. stroke cylinder.

### Internal Structure

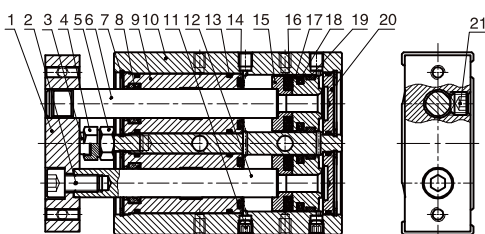

No.	Part Name	Material
1	Fixing plate	Aluminum alloy
2	Nut	Carbon steel
3	Bumper	POM
4	Adjustable nut	Carbon steel
5	Screw	Carbon steel
6	Piston rod	S45C hard chrome carbon steel
7	C clip	Spring steel
8	Wiper seal	NBR
9	Head cover	Aluminum alloy
10	Body	Aluminum alloy
11	Hex fix screw	Cu
12	Piston rod	S45C hard chrome carbon steel
13	O-ring	NBR
14	Anti-bump cushion	TPU
15	Magnet holder	Aluminum alloy
16	Magnet	Plastic
17	Piston	Aluminum alloy
18	Piston seal	NBR
19	Wear ring	PTFE
20	Rear cover	Aluminum alloy
21	Hex fix screw	Cu

## Main Dimension

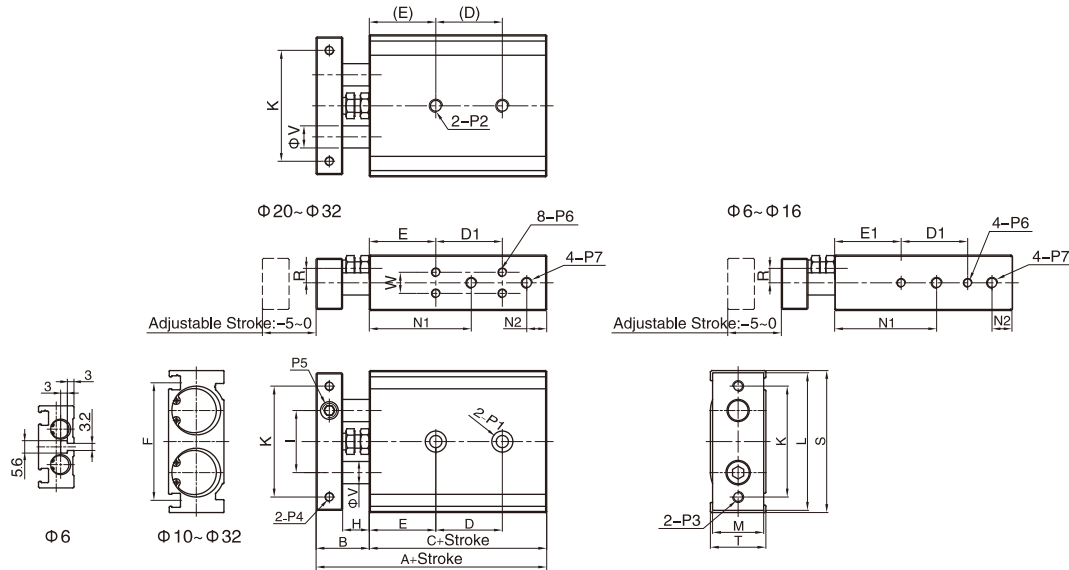

(mm)

Bore\Sign	A	B	C	D D1								E	E1	F	H	I	K	L	M	N1	N2	R
				10-25	30-50	60-80	90-100	125	150	175	200											
6	58.5	13.5	45	$D = 10 + \text{Stroke}/2$	$D1 = 13 + \text{Stroke}$	-	-	-	-	-	-	13	10	25.8	8	16	28	35	14	24.5	6.5	4.5
10	72	17	55	30	40	50	60	-	-	-	-	20	20	36.5	9	20	35	44	15	30	8	3.5
16	79	19	60	25	35	45	55	65	75	145	145	30	30	47.5	9	25	45	56	18	38	8	5
20	94	24	70	30	40	60	60	80	80	100	100	30	-	53	12	28	50	62	23	46	9	6.5
25	96	24	72	30	40	60	60	80	80	100	100	30	-	64	12	35	60	78	28	43	9	9
32	112	30	82	40	50	70	70	90	90	110	110	30	-	76	14	44	75	96	36	53	10	11.5

Bore\Sign	S	T	V	W	P1	P2	P3	P4	P5	P6	P7
6	37	16	4	-	Φ6.5 Dp:3.3; Thru.hole: Φ3.4	-	M3X0.5	M3X0.5	M3X0.5	M3X0.5 Dp:4.5	M5X0.8
10	46	17	6	-	Φ6.5 Dp:3.3; Thru.hole: Φ3.4	M4X0.7 Dp:7	M4X0.7	M3X0.5	M5X0.8	M3X0.5 Dp:5	M5X0.8
16	58	20	8	-	Φ8 Dp:4.4; Thru.hole: Φ4.3	M5X0.8 Dp:8	M5X0.8	M4X0.7	M6X1.0	M4X0.7 Dp:5	M5X0.8
20	64	25	10	9.5	Φ9.5 Dp:5.3; Thru.hole: Φ5.2	M6X1.0 Dp:10	M5X0.8	M4X0.7 Dp:6	M8X1.25	M4X0.7 Dp:5.5	M5X0.8
25	80	30	12	13	Φ11 Dp:6.3; Thru.hole: Φ6.8	M8X1.25 Dp:12	M6X1.0	M5X0.8 Dp:7.5	M8X1.25	M5X0.8 Dp:7	1/8"
32	98	38	16	20	Φ11 Dp:6.3; Thru.hole: Φ6.8	M8X1.25 Dp:12	M6X1.0	M5X0.8 Dp:8	M10X1.5	M5X0.8 Dp:7	1/8"

## EMQ

### Rotary Cylinder

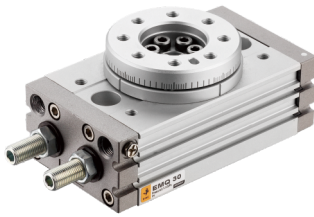
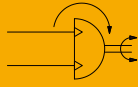

### Specifications

Bore Size(mm)		7	10	20	30	50
Acting type		Double Cylinder,Rack & Pinion Style,Double Acting				
Working medium		Clean Air(40um filtration or better)				
Working pressure range	With angle adjustable screw	0.1~0.7MPa		0.1~1.0MPa		
	With shock absorber	None		0.1~0.6MPa		
Proof pressure(MPa)		1.5MPa				
Working temperature ( °C )		-20~80 (Adjustment bolt); -10~80 (Shock absorber)				
Angle adjustable range		0~190°				
Repeat Accuracy	With angle adjustable screw	0.2°				
	With shock absorber	None		0.05°		
Theoretical Torque(NM)(0.5Mpa)		0.63	1.1	2.2	2.8	5.0
Cushion	With angle adjustable screw	Rubber bumper(Standard)				
	With shock absorber	None		Shock absorber(Optional)		
Port size	Front port	M5x0.8			G1/8①	
	Side port	M5x0.8			M5x0.8	
Weight(g)	With angle adjustable screw	270	530	1020	1310	2130
	With shock absorber	None	540	1020	1310	2140

Note: When setting the rotation angle for rotary tables with shock absorbers, following the above table. Failing to follow the guide may result in a decrease in energy absorption capacity.

① PT、NPT port size is optional

Bore Size(mm)		10	20	30	50
Minimum rotation angle that will not allow decrease of energy absorption ability		61°	52°	46°	66°

### How to Order?

Series No	Bore	Magnet No	Cushion Type	Thread Type
EMQ	7 10 20 30 50	S: With magnet (Magnet is standard)	A: With adjustment bolt R: With shock absorber (7 series no shock absorber is optional)	Blank: G P: PT T: NPT

#### Order Example:

EMQ Series Rotary Cylinder, Bore 30, with adjustment bolt, G Thread, ERP code is: EMQ30-S-A  
Note: Specific Bore and Stroke of the cylinder subject to the drawing.

### Optional Accessories

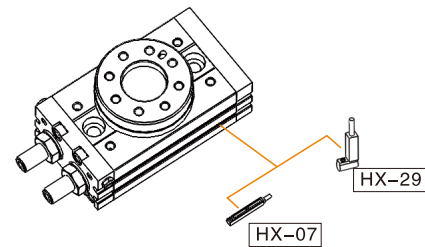

Note: Short stroke please use HX-29 series due to limited space.

### Allowable Kinetic Energy and Rotation Time Adjustment Range

Model	Allowable kinetic energy (J)		Rotation time adjustment range for stable operation (s/90°)	
	With adjutment bolt	With shok absorber	With adjutment bolt	With shok absorber
EMQ7	0.006	None	0.2~1.0	None
EMQ10	0.01	0.04	0.2~1.0	0.2~0.7
EMQ20	0.025	0.12	0.2~1.0	0.2~0.7
EMQ30	0.05	0.12	0.2~1.0	0.2~0.7
EMQ50	0.08	0.30	0.2~1.0	0.2~0.7

Note 1. If operated where the kinetic energy exceeds the allowable value, this may cause damage to the internal parts and result in product failure. Please pay special attention to the kinetic energy levels when designing and during operation to avoid exceeding the allowable limit.  
2. When the rotation time of the type with an internal absorber is set longer than the time shown in the table above, energy absorption of the shock absorber greatly decreases.

### Effective Output Torque

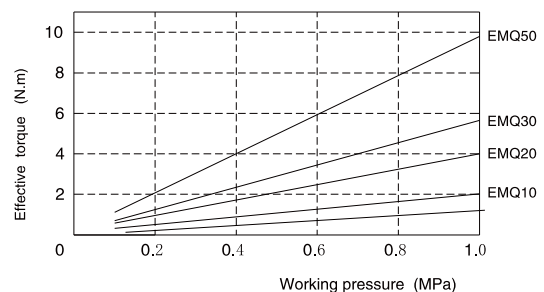

## Installation and Use

### 1. Rotation direction and rotation angle

- 1.1 When pressurized from port A, the shaft rotates clockwise and counter-clockwise when pressurized from port B.
- 1.2 To obtain the desired rotation angle, the rotation ends can be set within the range shown in the diagram by regulating the adjustment bolt.
- 1.3 Rotary table with a shock absorber is available to adjust the rotation angle.

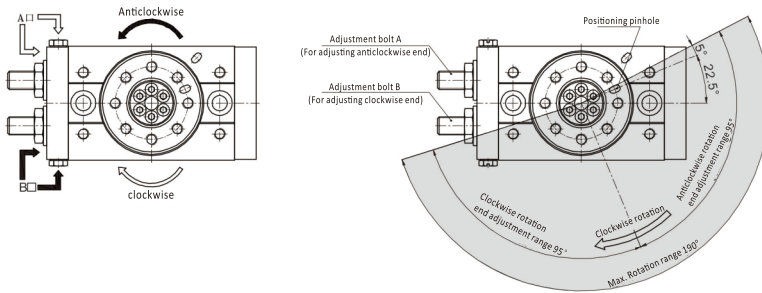

#### Note:

- \* The figure above shows the rotation range of from the positioning pinhole.
- \* Position of the pinhole in the figure above shows a counter-clockwise rotation where the rotation angle is set at 180° by equally tightening the A & B adjustment bolts.
- \* The adjustment bolt of the shock absorber is factory set to the maximum output. Please adjust inward for first use if necessary.

### 2. Rotation range example:

- 2.1 Rotation can be set by adjusting the A & B adjuster bolts.
- 2.2 Rotary tables with shock absorbers can be set to various angles.

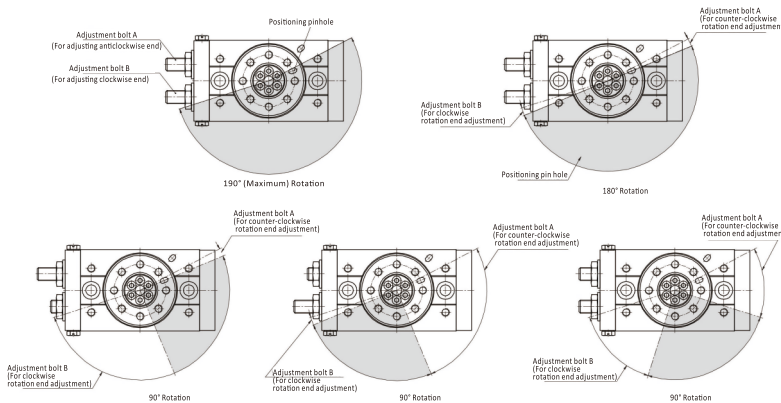

### 3. Adjustment angle per rotation (Adjustment bolt or shock absorber)

Bore size	Adjustment angle per rotation
7	10.2°
10	10.2°
20	7.4°
30	6.5°
50	8.2°

- 4. The rotation angle has been adjusted to the maximum output at the factory. Please do not extend the rotation angle beyond the maximum factory setting.
- 5. The movement energy should not exceed the maximum allowable energy, or the inner components can be damaged.
- 6. The rotary parts do not require lubrication.
- 7. Minimum operation pressure for a rotary table with a shock absorber is no less than 0.1Mpa.

### 8. Refer to the table below for tightening torques of the shock absorber setting nut.

Shock absorber size	Max. tightening torque (Nm)
M8X1.0	2.5
M10X1.0	3.5
M14X1.5	11

### 9. Never loosen the bottom screw of the shock absorber.

That may cause oil leakage.

### 10. Shock absorbers are consumable parts. When a decrease in energy absorption capacity is noticed, it must be replaced.

Series	Shock Absorber Type and Ordering code	Thread Type
EMQ10	AC0806-SN	M8X1.0
EMQ20	AC1007-SN	M10X1.0
EMQ30	AC1007-SN	M10X1.0
EMQ50	AC1412-SN	M14X1.5

### 11. Control the runout and parallelism of the dial according to the requirements of the following table:

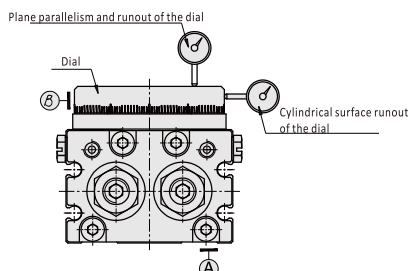

Items	Specific Requirements (mm)	Relative Datum
Plane parallelism of the dial	0.1	A
Plane runout of the dial	0.1	A
Cylindrical surface runout of the dial	0.1	B

# EMQ Series Rotary Cylinder



## Internal Structure

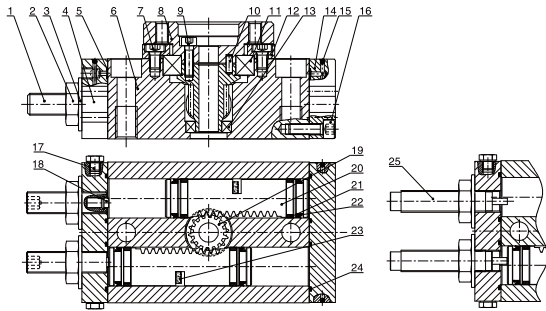

No.	Part Name	Material	No.	Part Name	Material
1	Adjustment screw	Carbon steel	14	Rear cover	Aluminum alloy
2	Hexagon nut	Carbon steel	15	Steel ball	Stainless steel
3	Seal washer	Carbon steel rubber coating	16	Hexagon socket head set screw	Carbon steel
4	Head cover	Aluminum alloy	17	Plug	Carbon steel
5	O-ring	NBR	18	Cushion pad	NBR
6	Barrel	Aluminum alloy	19	Pinion	Alloy steel
7	Hexagon socket head set screw	Carbon steel	20	Rack	Alloy steel
8	Dial	Aluminum alloy	21	Wear ring	PTFE
9	Hexagon socket head set screw	Carbon steel	22	Piston seal	NBR
10	Positioning pin	Stainless steel	23	Magnet	Sintered NdFeB
11	Deep groove ball bearing	Subassembly	24	O-ring	NBR
12	Plate	Aluminum alloy	25	Shock absorber	Subassembly
13	Deep groove ball bearing	Subassembly			

## Main Dimension

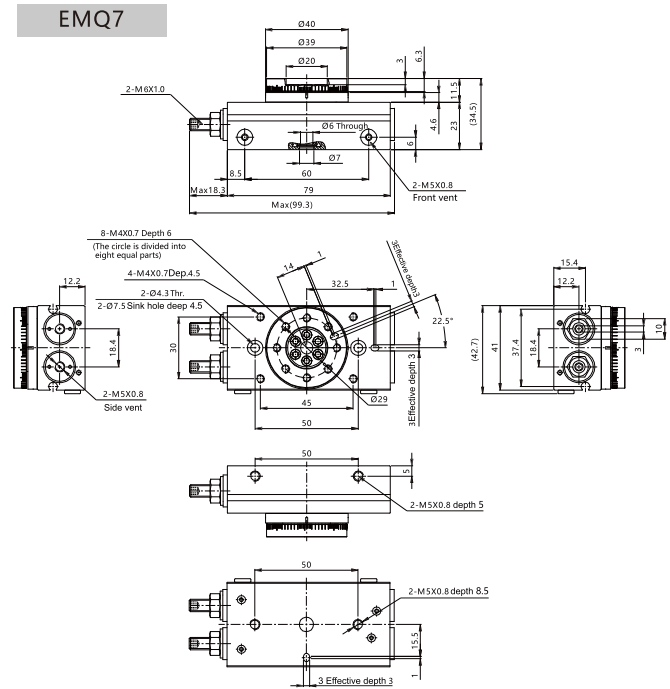

## EMQ10~50

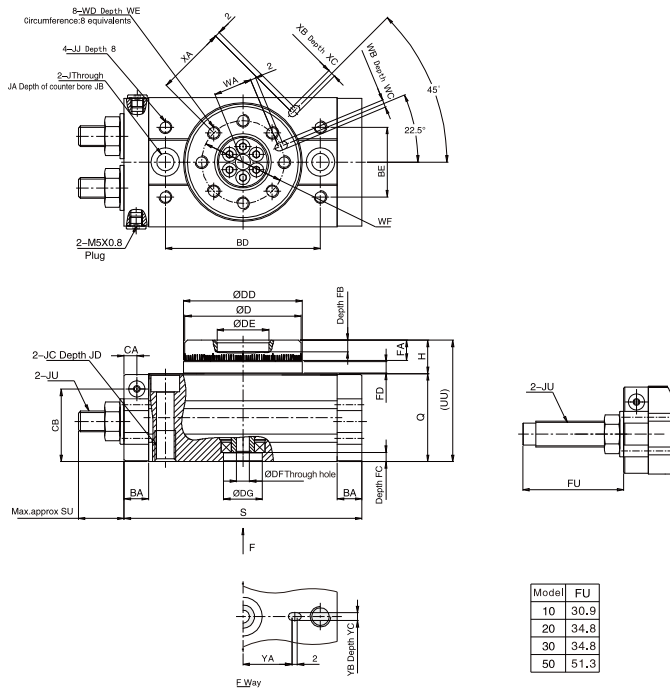

Model	FU
10	30.9
20	34.8
30	34.8
50	51.3

Model	AA	A	AV	AW	AY	BA	BB	BC	BD	BE	CA	CB	D	DD	DE	DF	DG	FA	FB	FC	FD	H	J	JA	JB	JC
10	52.8	50	20	15.5	4	9.5	34.5	28	60	27	5	28	45 <sup>0</sup> <sub>-0.062</sub>	46 <sup>0</sup> <sub>-0.062</sub>	20 <sup>+0.052</sup> <sub>0</sub>	5	15 <sup>+0.043</sup> <sub>0</sub>	7.8	4.5	3.5	4.5	13	6.8	11	6.5	M8X1.25
20	67.8	65	27.5	16	5	12	47	30	76	34	6.5	30	60 <sup>0</sup> <sub>-0.074</sub>	61 <sup>0</sup> <sub>-0.074</sub>	28 <sup>0</sup> <sub>-0.062</sub>	9	17 <sup>+0.043</sup> <sub>0</sub>	9.8	6.5	3	6.5	17	8.6	14	8.5	M10X1.5
30	72.4	70	29	18.5	5	12	50	32.5	84	37	7	33.5	65 <sup>0</sup> <sub>-0.074</sub>	67 <sup>0</sup> <sub>-0.074</sub>	32 <sup>0</sup> <sub>-0.062</sub>	10	22 <sup>+0.052</sup> <sub>0</sub>	9.8	5	3.5	6.5	17	8.6	14	8.5	M10X1.5
50	82.4	80	38	22	6	15.5	63	37.5	100	50	10	37.5	75 <sup>0</sup> <sub>-0.074</sub>	77 <sup>0</sup> <sub>-0.074</sub>	38 <sup>0</sup> <sub>-0.062</sub>	11	26 <sup>+0.052</sup> <sub>0</sub>	11.8	5.5	3.5	7.5	20	10.3	18	10.5	M12X1.75
Model	JD	JJ	JU	P	Q	S	SD	SE	SF	SU	UU	WA	WB	WC	WD	WE	WF	XA	XB	XC	YA	YB	YC			
10	12	M5X0.8	M8X1	M5X0.8	34	92	9	13	45	17.3	47	15	3 <sup>+0.025</sup> <sub>0</sub>	3.5	M5X0.8	8	32	27	3 <sup>+0.025</sup> <sub>0</sub>	3.5	19	4 <sup>+0.025</sup> <sub>0</sub>	3.5			
20	15	M6X1	M10X1	M5X0.8	37	117	10	12	59.7	24.8	54	20.5	4 <sup>+0.03</sup> <sub>0</sub>	4.5	M6X1	10	43	36	4 <sup>+0.03</sup> <sub>0</sub>	4.5	24	4 <sup>+0.03</sup> <sub>0</sub>	4.5			
30	15	M6X1	M10X1	1/8"	40	127	11.5	14	64.7	24.8	57	23	4 <sup>+0.03</sup> <sub>0</sub>	4.5	M6X1	10	48	39	4 <sup>+0.03</sup> <sub>0</sub>	4.5	28	4 <sup>+0.03</sup> <sub>0</sub>	4.5			
50	18	M8X1.25	M14X1.5	1/8"	46	152	14.5	15	74.7	31.3	66	26.5	5 <sup>+0.03</sup> <sub>0</sub>	5.5	M8X1.25	12	55	45	5 <sup>+0.03</sup> <sub>0</sub>	5.5	33	5 <sup>+0.03</sup> <sub>0</sub>	5.5			

## SHY Air Gripper

SHY:  
Standard double acting

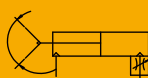

SHYSA:  
Single acting (N.O.)

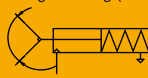

### Specifications



Bore size(mm)		10	16	20	25
Acting type		Double Acting/Single Acting			
Working medium		Clean Air(40 μ m filtration)			
Applicable pressure range	Double acting	Φ 10	0.15~0.7MPa(22~100psi)(1.5~7.0bar)		
		Φ 16~Φ 25	0.1~0.7MPa(15~100psi)(1.0~7.0bar)		
	Single acting	Φ 10	0.3~0.7MPa(45~100psi)(3.0~7.0bar)		
		Φ 16~Φ 25	0.25~0.7MPa(36~100psi)(2.5~7.0bar)		
Working temperature		-20~80°C(No freezing)			
Oil		Not required			
Maximum frequency		180(C.P.M)			
Port size		M3X0.5		M5X0.8	
Weight(g)		42	94	174	303

### How to Order?

Series	Type No.	Bore	Magnet No.
SHY:Y type gripper	Blank: Basic type SA: Single acting (N.O.)	10 16 20 25	S : With magnet (Magnet is standard)

Order Example:

SHY Series Air Gripper, Bore25, with magnet, ERP code is: SHY25-S

### Product Features

1. Single piston structure, large gripping torque.
2. Integrated with variable throttle valve, easy to adjust the gripping jaw opening & closing speed.
3. Reasonable gripping angle, wide range of application.
4. Accurate positioning accuracy, it is more accurate and reliable when gripping workpiece.
5. Multi mounting type, convenient for use in different application.
6. All series with magnet, easy to control.

### Optional Accessories

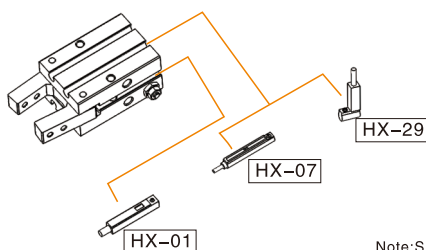

Note: Short stroke please use HX-29 series due to limited space.

### Theoretical Clamping Torque

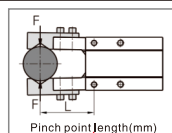

Acting type	Type	Theoretical clamping moment(N · cm)		Max pinch point length (L)(mm)	Open angle	Closure angle
		Closure clamping torque	Open clamping torque			
Double acting	SHY10	17.6XP	29.4XP	30	30°	-10°
	SHY16	90XP	129XP	40		
	SHY20	152XP	252XP	60		
	SHY25	304XP	473XP	70		
Single acting (N.O.)	SHYSA10	11.8XP	-	30		
	SHYSA16	71.2XP	-	40		
	SHYSA20	122.4XP	-	60		
	SHYSA25	252XP	-	70		

Note: In the above table, "P" represents the actual use of pneumatic pressure, "P" unit: Mpa

# SHY Series Air Gripper



## Internal Structure

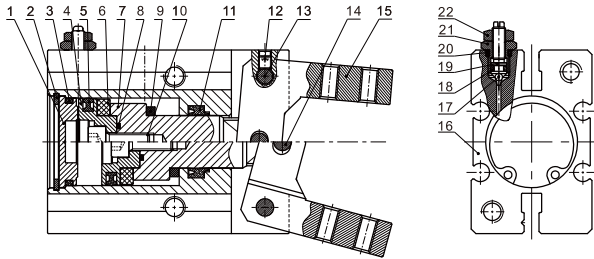

No.	Part Name	Material	No.	Part Name	Material
1	Rear cover	Aluminum alloy	12	Hexagon socket set screw	Carbon steel
2	C type retainer ring	Spring steel	13	Pin	Stainless steel
3	O-ring	NBR	14	Pin	Stainless steel
4	Piston	Aluminum alloy/Stainless steel(Φ10)	15	Claw	Cast steel
5	Piston seal	NBR	16	Barrel	Aluminum alloy
6	Magnet	Plastic	17	Steel ball	Stainless steel
7	Piston rod	Aluminum alloy/Stainless steel (Φ10, Φ16)	18	O-ring	NBR
8	O-ring	NBR	19	Buffer screw	Brass
9	Anti-bump cushion	PTEE	20	O-ring	NBR
10	Hexagon socket cap screw	Carbon steel	21	Buffer fixing screw	Brass
11	Piston rod seal	TPU/NBR(Φ25)	22	Hexagon nut	Carbon steel

## Main Dimension

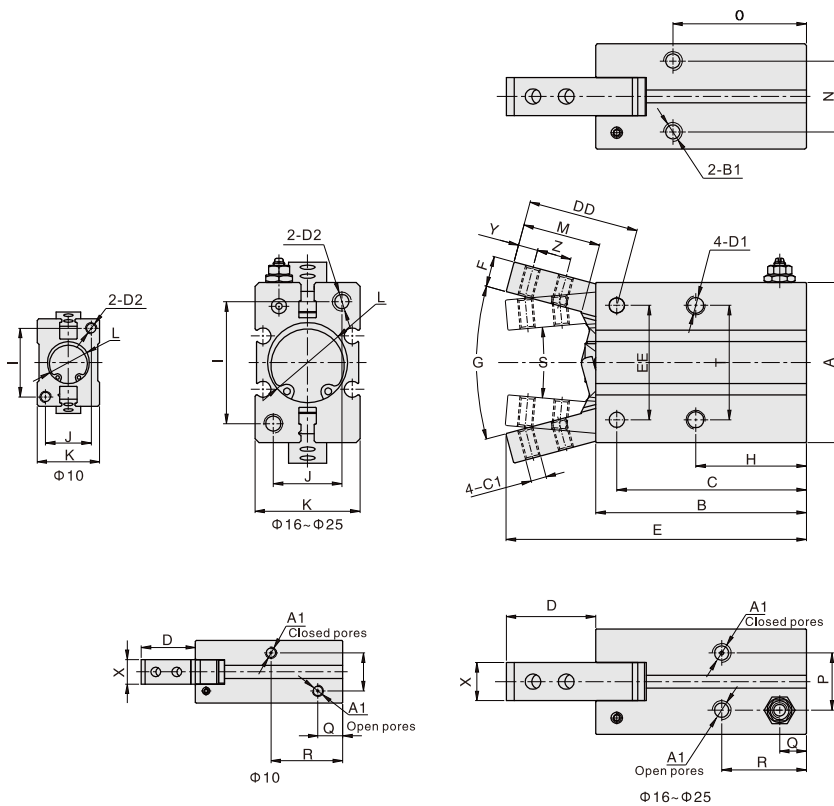

Bore/Sign	A	A1	B	B1	C	C1	D	DD	D1	D2	E	EE						
SHY10	23	M3X0.5	38.6	M3X0.5Depth6	35.8	M2.5X0.45	14.2	17.2	M3X0.5Depth6	M3X0.5Depth6	52.8	14						
SHY16	30.6	M5X0.8	44.6	M4X0.7Depth5.5	39.7	M3X0.5	18.9	23.6	M4X0.7Depth9.5	M4X0.7Depth8	63.5	24						
SHY20	42	M5X0.8	55.2	M5X0.8Depth8	49.7	M4X0.7	23.5	29	M5X0.8Depth11.5	M5X0.8Depth10	78.7	30						
SHY25	52	M5X0.8	60.4	M6X1.0Depth10	54.8	M5X0.8	32.8	38.5	M6X1.0Depth14.5	M6X1.0Depth12	93.2	36						
Bore/Sign	F	G	H	I	J	K	L	M	N	O	P	Q	R	S	T	X	Y	Z
SHY10	4	30°	23	18	12	16.4	Φ11Depth1.5	12.5	11.4	27	10	6.5	18.8	10°	16	7.4	3	5.7
SHY16	7	30°	24.5	22	15	23.6	Φ17Depth1.5	16.5	16	30	13	6.5	18.3	10°	24	10	4	7
SHY20	8	30°	29	32	18	27.6	Φ21Depth1.5	20.5	18.6	35	15	7	22.2	10°	30	12	5.2	9
SHY25	10	30°	30	40	22	33.6	Φ26Depth1.5	27.5	22	36.5	19.5	7.4	23.5	10°	36	12	8	12

## Installation and Use

1. Installing a fall prevention device is recommended when applying a lowering clamping force. In the case of a sudden pressure decrease due to emergency stop, these prevention devices can help to avoid personal or equipment injuries.
2. Air grippers are not intended for use under strong external or heavy impact forces.
3. When installing or repairing your air gripper take precautions to safely use your component.
4. Don't reverse the clamping gripper when installing clamping parts.
5. The locking torque of the fastening screw must be within the prescribed torque range shown in the chart below. If the locking torque is not set properly the unit will not perform correctly.

### Tail Mounting Type

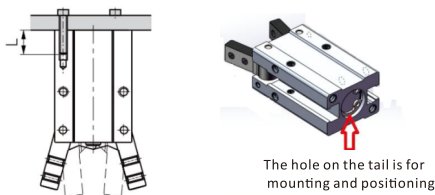

Bore	Bolt Size	Max.Locking Torque (Nm)	Max.Screwed Depth (mm)	Tail Positioning Bore Dia(mm)	Tail positioning Depth(mm)
10	M3X0.5	0.88	6	φ 11H9	1.5
16	M4X0.7	2.1	8	φ 17H9	1.5
20	M5X0.8	4.3	10	φ 21H9	1.5
25	M6X1.0	7.3	12	φ 26H9	1.5

### Front Tapped Hole Mounting

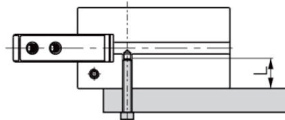

Bore	Bolt Size	Max.Locking Torque (Nm)	Max.Screwed Depth (mm)
10	M3X0.5	0.69	5
16	M4X0.7	2.1	8
20	M5X0.8	4.3	10
25	M6X1.0	7.3	12

### Through Hole Mounting

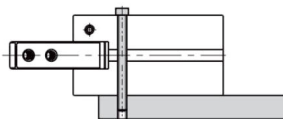

Bore	Bolt Size	Max.Locking Torque (Nm)	Max.Screwed Depth (mm)
10	M2.5X0.45	0.49	5
16	M3X0.5	0.88	8
20	M4X0.7	2.1	10
25	M5X0.8	4.3	12

### Side Tapped Hole Mounting

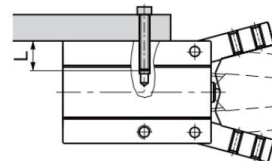

Bore	Bolt Size	Max.Locking Torque (Nm)	Max.Screwed Depth (mm)
10	M3X0.5	0.88	6
16	M4X0.7	1.6	6.5
20	M5X0.8	3.3	8
25	M6X1.0	5.9	10

### 6. Clamping Jaw Installation:

Never clamp the body directly and then lock the screws. The gripping jaw should be held by the spanner and the screw should be locked using a hex wrench.

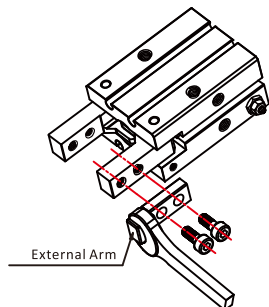

Bore	Bolt Size	Max.Locking Torque (Nm)
10	M2.5X0.45	0.31
16	M3X0.5	0.59
20	M4X0.7	1.4
25	M5X0.8	2.8

7. When gripping an object, the item must be placed in the centre of the two gripping jaws, and the two gripping jaws should touch the object at the same time.
8. Avoid applying external forces to the gripping jaw. Always leave enough space to adequately grip and place your object. The gripper should be free moving.
9. When gripping an object the item should always be centred. When testing, you must reduce the pressure for low speed running, to guarantee the safety and no impact.
10. Please use the flow control valve to adjust the opening and closing speed of your gripper.
11. Always ensure the gripper path is clear of obstruction.
12. Before removing your air gripper, please make sure all power is disconnected and you've discharged residual compressed air.

## SHZ

Air Gripper

SHZ:  
Standard double acting

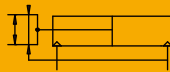

SHZSA:  
Single acting (N.O.)

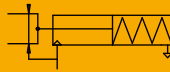

SHZSB:  
Single acting (N.C.)

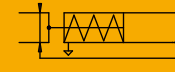

### Specifications

Bore size(mm)		10	16	20	25
Acting type		Double Acting/Single Acting			
Working medium		Clean Air(40 μ m filtration)			
Applicable pressure range	Double acting	Φ 10	0.15~0.7MPa(22~100psi)(1.5~7.0bar)		
		Φ 16~Φ 25	0.1~0.7MPa(15~100psi)(1.0~7.0bar)		
	Single acting	Φ 10	0.3~0.7MPa(45~100psi)(3.0~7.0bar)		
		Φ 16~Φ 25	0.25~0.7MPa(36~100psi)(2.5~7.0bar)		
Working temperature		-20~80°C(No freezing)			
Oil		Not required			
Maximum frequency		180(C.P.M)			
Port size		M3X0.5	M5X0.8		
Weight(g)		52	120	236	430

### How to Order?

Series	Type No.	Bore	Magnet No.
SHZ: Parallel air gripper	Blank; Basic type SA: Single acting (N.O.) SB: Single acting (N.C.)	10 16 20 25	S : With magnet (Magnet is standard)

Order Example:

Parallel air gripper, Bore 20, with magnet, ERP code is: SHZ20-S

### Product Features

1. Integrated design of linear guide rail, high rigidity, high precision;
2. Positioning pin at the bottom of the linear guide rail, efficiently preventing deviation of guide rail from the body;
3. Deeper attached fixing benchmark centering hole, improving fixing accuracy, and improving consistency after repeated dismounting and fixing
4. According to the actual requirements of the customer, the initial position of the claw can be customized to meet the different needs under different working conditions.

### Optional Acces

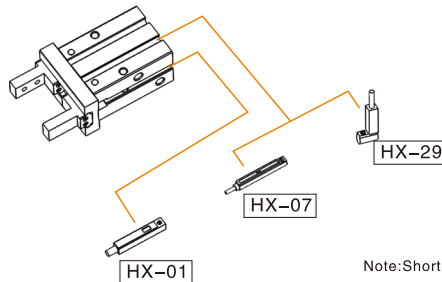

Note: Short stroke please use HX-29 series due to limited space.

### Clamping Force and Stroke

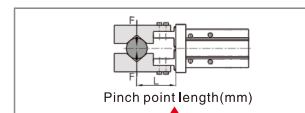

Acting Type	Type	Clamping force effective value of single air finger(N)		Stroke(two sides) (L) ( mm )	
		Closure clamping torque	Open clamping torque		
Double acting	SHZ10	11	17	4	
	SHZ16	34	45	6	
	SHZ20	45	68	10	
	SHZ25	69	102	14	
Single acting (N.O.)	(N.O.)	SHZSA10	7	-	4
		SHZSA16	27	-	6
		SHZSA20	35	-	10
		SHZSA25	55	-	14
	(N.C.)	SHZSB10	-	13	4
		SHZSB16	-	38	6
		SHZSB20	-	59	10
		SHZSB25	-	87	14

Note: The value of the clamping force in above table is when the working pressure is 0.5Mpa and the L value of the clamping point is 20mm.

## Internal Structure

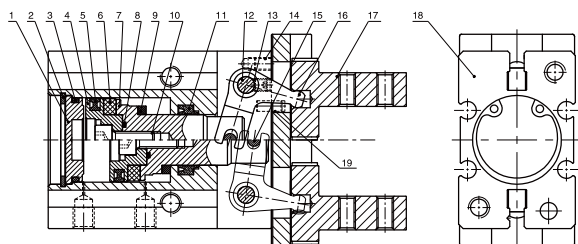

No.	Part Name	Material	No.	Part Name	Material
1	Rear cover	Aluminum alloy	11	Piston rod seal	TPU/NBR(φ25)
2	C type retainer ring	Spring steel	12	Pin	Stainless steel
3	O-ring	NBR	13	Hexagon set screw	Carbon steel
4	Piston	Aluminum alloy/ Stainless steel (φ10)	14	Hexagon socket cap screw	Carbon steel
5	Piston seal	NBR	15	Pin	Stainless steel
6	Magnet	Plastic	16	Bent lever	Alloy steel
7	Piston rod	Aluminum alloy/ Stainless steel (φ10, φ16)	17	Clamping jaw assembly	Assembly
8	O-ring	NBR	18	Barrel	Aluminum alloy
9	Anti-bump cushion	PTEE	19	Pin	Stainless steel
10	Hexagon socket cap screw	Carbon steel			

## Main Dimension

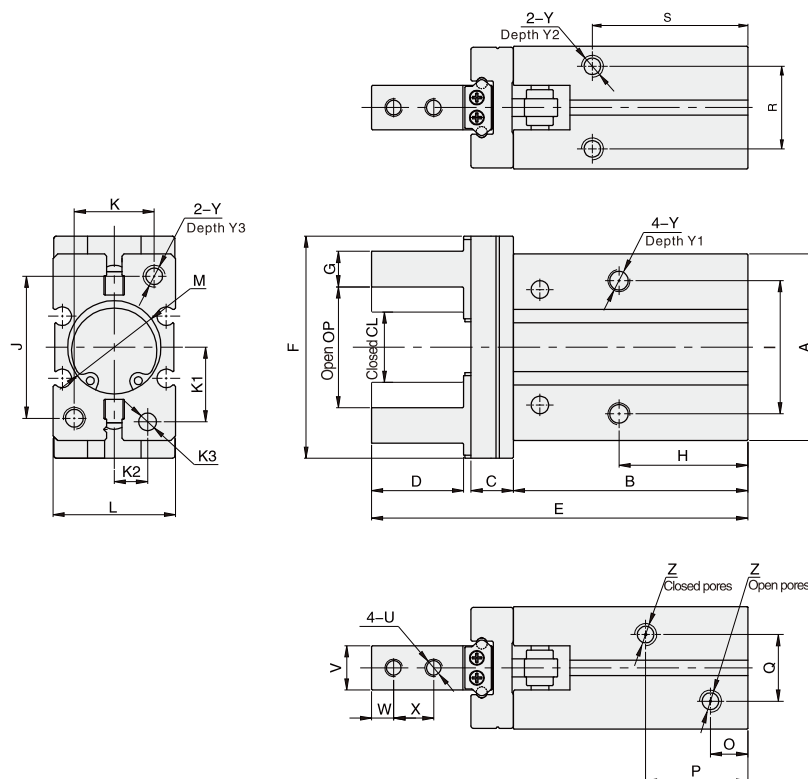

Bore/Sign	A	B	C	D	E	F	G	H	I	J	K	L	M	O	P	Q	K1	K2	K3
SHZ10	23	37.6	6	12.3	57	29	4 <sup>0</sup> <sub>-0.05</sub>	23	16	18	12	16.4	11 <sup>+0.05</sup> <sub>0</sub> Depth2	7	18.8	10	7.6	5.2	2 <sup>+0.05</sup> <sub>0</sub> Depth3
SHZ16	30.6	42.5	7.5	15.5	67.3	38	5 <sup>0</sup> <sub>-0.05</sub>	24.5	24	22	15	23.6	17 <sup>+0.05</sup> <sub>0</sub> Depth2	7.1	18.5	13	11	6.5	3 <sup>+0.05</sup> <sub>0</sub> Depth3
SHZ20	42	52.8	9.5	20.7	84.7	50	8 <sup>0</sup> <sub>-0.05</sub>	29	30	32	18	27.6	21 <sup>+0.05</sup> <sub>0</sub> Depth3	8.4	23	15	16.8	7.5	4 <sup>+0.05</sup> <sub>0</sub> Depth4
SHZ25	52	63.6	11	25.5	102.7	63	10 <sup>0</sup> <sub>-0.05</sub>	30	36	40	22	33.6	26 <sup>+0.05</sup> <sub>0</sub> Depth3.5	9.5	23.5	19.5	21.8	10	4 <sup>+0.05</sup> <sub>0</sub> Depth4
Bore/Sign	R	S	U	W	V	X	Y	Y1	Y2	Y3	Z	OP	CL						
SHZ10	11.4	27	M2.5X0.45	3	5 <sup>0</sup> <sub>-0.05</sub>	5.7	M3X0.5	6	6	6	M3X0.5	14.8 <sup>+2</sup> <sub>0</sub>	11.4 <sup>0</sup> <sub>0.7</sub>						
SHZ16	16	30	M3X0.5	4	8 <sup>0</sup> <sub>-0.05</sub>	7	M4X0.7	9.5	5.5	8	M5X0.8	20.8 <sup>+2</sup> <sub>0</sub>	14.8 <sup>0</sup> <sub>0.7</sub>						
SHZ20	18.6	35	M4X0.7	5	10 <sup>0</sup> <sub>-0.05</sub>	9	M5X0.8	11.5	8	10	M5X0.8	26 <sup>+2</sup> <sub>0</sub>	16.2 <sup>0</sup> <sub>0.7</sub>						
SHZ25	22	36.5	M5X0.8	6	12 <sup>0</sup> <sub>-0.05</sub>	12	M6X1.0	14.5	10	12	M5X0.8	33.5 <sup>+2</sup> <sub>0</sub>	19.2 <sup>0</sup> <sub>0.7</sub>						

## Installation and Use

1. Installing a fall prevention device is recommended when applying a lowering clamping force. In the case of a sudden pressure decrease due to emergency stop, these prevention devices can help to avoid personal or equipment injuries.
2. Don't use air gripper upon strong external force and impact force. Air grippers are not intended for use under external or impact forces.
3. When installing or repairing your air gripper take precautions to safely use your component.
4. Please contact with us when using the single acting type gripper for specific spring action force information.
5. Don't reverse the clamping gripper when installing clamping parts.
6. The locking torque of the fastening screw must be within the prescribed torque range shown in the chart below. If the locking torque is not set properly the unit will not perform correctly.

### Tail Mounting Type

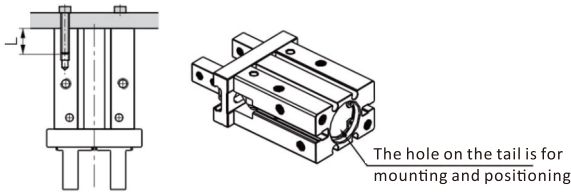

Bore	Bolt Size	Max.Locking Torque (Nm)	Max.Screwed Depth (mm)	Tail Positioning Bore Dia(mm)	Tail positioning Depth(mm)
10	M3X0.5	0.88	6	$\phi 11_{-0.05}^{+0.05}$	2
16	M4X0.7	2.1	8	$\phi 17_{-0.05}^{+0.05}$	2
20	M5X0.8	4.3	10	$\phi 21_{-0.05}^{+0.05}$	3
25	M6X1.0	7.3	12	$\phi 26_{-0.05}^{+0.05}$	3.5

### Front Tapped Hole Mounting

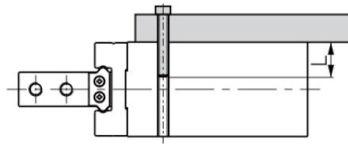

Bore	Bolt Size	Max.Locking Torque (Nm)	Max.Screwed Depth (mm)
10	M3X0.5	0.69	5
16	M4X0.7	2.1	8
20	M5X0.8	4.3	10
25	M6X1.0	7.3	12

### Through Hole Mounting

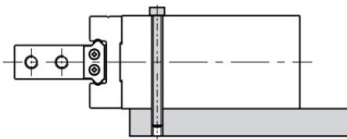

Bore	Bolt Size	Max.Locking Torque (Nm)	Max.Screwed Depth (mm)
10	M2.5X0.45	0.49	5
16	M3X0.5	0.88	8
20	M4X0.7	2.1	10
25	M5X0.8	4.3	12

### Side Tapped Hole Mounting

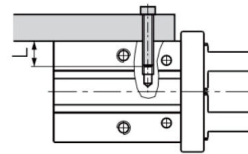

Bore	Bolt Size	Max.Locking Torque (Nm)	Max.Screwed Depth (mm)
10	M3X0.5	0.9	6
16	M4X0.7	1.6	4.5
20	M5X0.8	3.3	8
25	M6X1.0	5.9	10

### 7. Clamping Jaw Installation:

Never clamp the body directly and then lock the screws. The gripping jaw should be held by the spanner and the screw should be locked using a hex wrench.

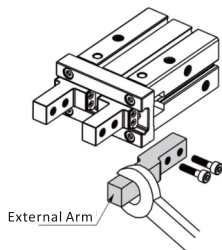

Bore	Bolt Size	Max.Locking Torque (Nm)
10	M2.5X0.45	0.31
16	M3X0.5	0.59
20	M4X0.7	1.4
25	M5X0.8	2.8

### 8. Avoid applying external forces to the gripping jaw.

#### 8.1 The air gripper end of stroke in open status.

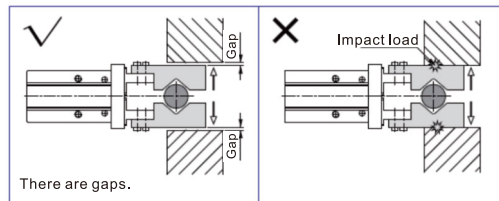

#### 8.2 The air gripper end of stroke in moving status.

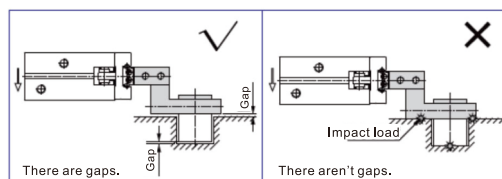

## Installation and Use

8.3 When reversing your loaded air gripper make sure the object being gripped is centred.

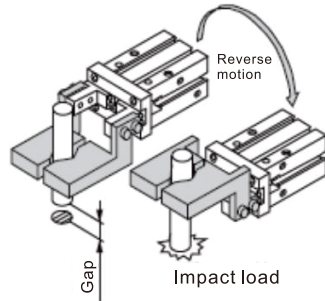

9. When ripping an object the item should always be centred. When testing, you must reduce the pressure for low speed running, to guarantee the safety and no impact.

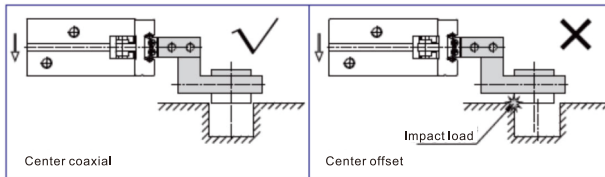

10. Please use the flow control valve to adjust the opening and closing speed of your gripper.

11. Always ensure the gripper path is clear of obstruction.

12. Before removing your air gripper, please make sure all power is disconnected and you've discharged residual compressed air.

# EXH Series Compact Slide Cylinder



## EXH

### Compact Slide Cylinder

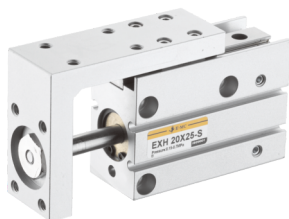
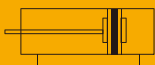

### Specifications

Bore(mm)	6	10	16	20
Acting type	Double Acting			
Working medium	Clean Air(40 μ m filtration)			
Working pressure (MPa)	0.15~0.7			
Guaranteed pressure (MPa)	1.05			
Working temperature (°C)	-20~80(No freezing)			
Speed range (mm/s)	50~500			
Cushion type	Rubber cushion			
Stroke tolerance(mm)	+1.0 0			
Allowable kinetic energy(J)	0.008	0.025	0.05	0.1
Port size	M5 × 0.8			

### How to Order?

Series No	Bore	X	Stroke	-	Magnet No
EXH	6 10 16 20		5 10 15 ...		S : With magnet

#### Order Example:

EXH series, linear bearing, bore 6mm, stroke 10mm,  
EPR code is: EXH6X10-S

### Stroke

Bore (mm)	Standard Stroke (mm)	Max. Stroke (mm)
6	5 10 15 20 25 30 40	40
10	5 10 15 20 25 30 40 50	50
16	5 10 15 20 25 30 40 50 60	60
20	5 10 15 20 25 30 40 50 60	60

### Optional Accessories

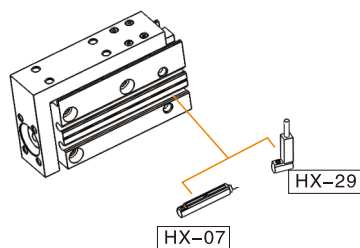

Note: Short stroke please use HX-29 series due to limited space.

### How to Mount ?

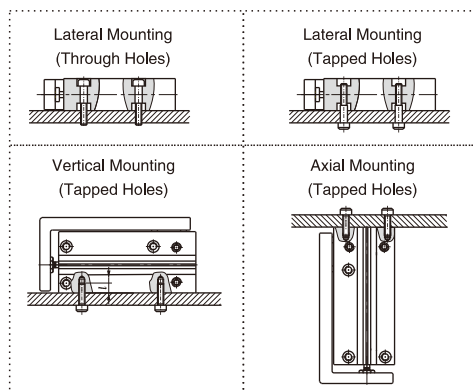

### Internal Structure

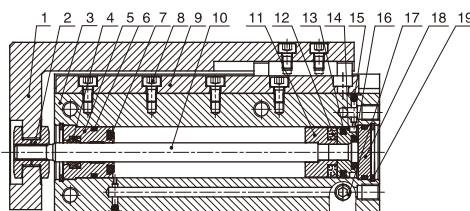

No.	Part Name	Material
1	Stages	Aluminum alloy
2	Locknut	Carbon steel
3	Body	Aluminum alloy
4	Wiper seal	NBR
5	Head cover	Aluminum alloy
6	O-ring	NBR
7	Bumper	TPU
8	Screws	Carbon steel
9	Linear ball slide rail	Stainless steel
10	Piston rod	Stainless steel
11	Magnet seat	Aluminum alloy
12	Magnet	Neodymium iron boron
13	Piston seal	NBR
14	Piston	Aluminum alloy
15	Steel ball	Stainless steel
16	Bumper	TPU
17	Plug	Cu
18	Rear cover	Aluminum alloy
19	C clip	Spring steel

## Main Dimension

EXH  $\Phi 6$

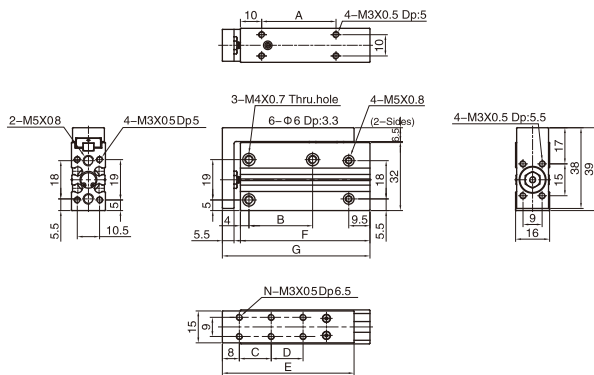

(mm)								
Bore\Sign	N	A	B	C	D	E	F	G
5	4	10	14	10	-	42	36	44.5
10	4	15	14	10	-	42	41	49.5
15	4	20	24	20	-	52	46	54.5
20	4	25	24	20	-	52	51	59.5
25	4	30	30	30	-	62	56	64.5
30	4	35	30	30	-	62	61	69.5
40	6	45	45	20	20	72	71	79.5

EXH  $\Phi 10$

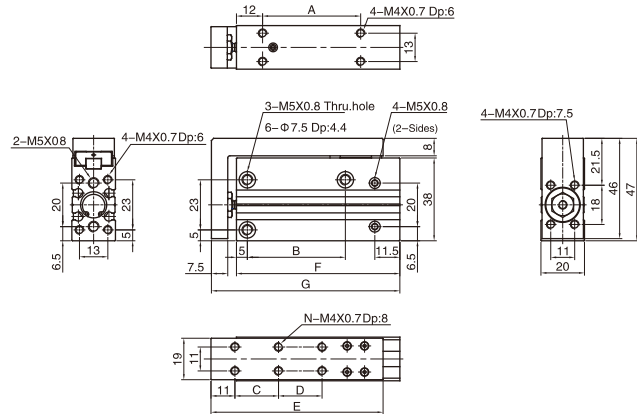

(mm)								
Bore\Sign	N	A	B	C	D	E	F	G
5	4	10	14	10	-	49	40	51.5
10	4	15	14	10	-	49	45	56.5
15	4	20	24	20	-	59	50	61.5
20	4	25	24	20	-	59	55	66.5
25	4	30	30	30	-	69	60	71.5
30	4	35	30	30	-	69	65	76.5
40	6	45	45	20	20	79	75	86.5
50	6	55	55	25	25	89	85	96.5

EXH  $\Phi 16$

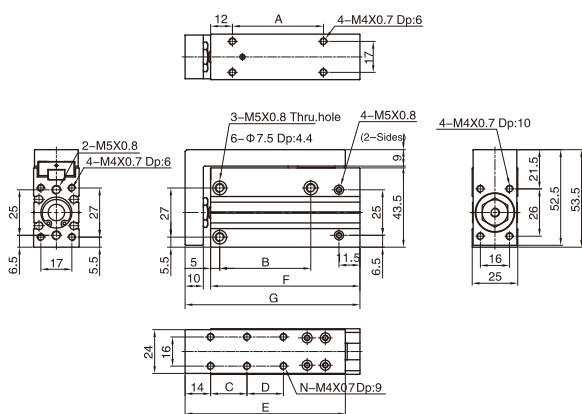

(mm)								
Bore\Sign	N	A	B	C	D	E	F	G
5	4	15	20	10	-	58	47	61
10	4	20	20	10	-	58	52	66
15	4	25	30	20	-	68	57	71
20	4	30	30	20	-	68	62	76
25	4	35	40	30	-	78	67	81
30	4	40	40	30	-	78	72	86
40	6	50	50	20	20	88	82	96
50	6	60	60	25	25	98	92	106
60	6	70	60	30	30	108	102	116

EXH  $\Phi 20$

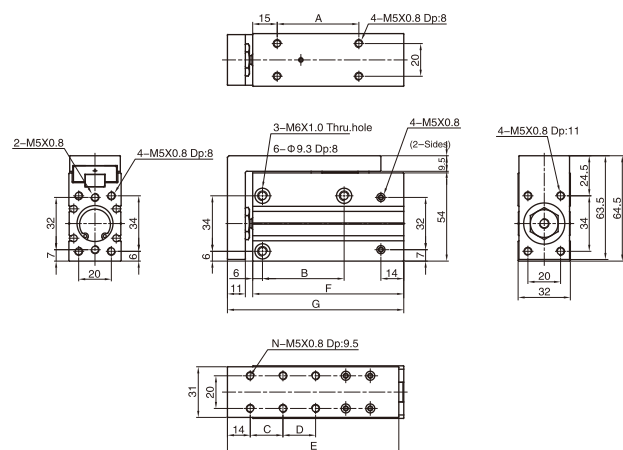

(mm)								
Bore\Sign	N	A	B	C	D	E	F	G
5	4	15	20	10	-	64	57.5	73
10	4	20	20	10	-	64	62.5	78
15	4	25	25	20	-	74	67.5	83
20	4	30	25	20	-	74	72.5	88
25	4	35	40	30	-	84	77.5	93
30	4	40	40	30	-	84	82.5	98
40	6	50	50	20	20	94	92.5	108
50	6	60	70	25	25	104	102.5	118
60	6	70	70	30	30	114	112.5	128

# ELS Series Slide Cylinder



## ELS

### Slide Cylinder



### Specifications

Bore(mm)	6	8	12	16	20	25
Acting Type	Double Acting					
Working Medium	Clean Air(after 40 μm filtration)					
Working Pressure(MPa)	0.15-0.7					
Guaranteed Pressure(MPa)	1.05					
Working Temperature(°C)	-20~80(No freezing)					
Piston Speed(mm/s)	50~500					
Stroke tolerance	Stroke ≤ 100 <sup>+1.0</sup> , Stroke > 100 <sup>+1.5</sup>					
Cushion	Rubber cushion on both ends, Shock absorber cushion					
Port Size	M5x0.8			G1/8		

### How to order?

Series No.	Bore X	Stroke	Magnet No.	Adjuster	Thread Type
ELS	6 8 12 16 20 25	Details in stroke chart	S: With magnet	Blank: None adjuster A: Adjusters on both ends AS: Forward adjuster AF: Backward adjuster B: Shock absorber on both ends BS: Forward shock absorber BF: Backward shock absorber	Blank: G

#### Order Example:

ELS Series Basic type cylinder, bore size 20, stroke 50, with Magnet, without adjuster, thread type G. The ERP code is: ELS20X50-S

### Optional Accessories

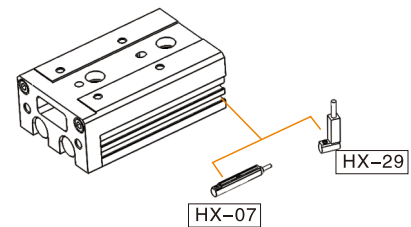

Note: Short stroke please use HX-29 series due to limited space.

### Stroke

Bore(mm)	Standard Stroke(mm)								Max.Stroke(mm)
Double Acting	6	10	20	30	40	50			50
	8	10	20	30	40	50			50
	12	10	20	30	40	50	75		75
	16	10	20	30	40	50	75	100	125
	20	10	20	30	40	50	75	100	125
25	10	20	30	40	50	75	100	125	

### Weight(g)

Bore(mm)	Stroke(mm)							
	10	20	30	40	50	75	100	125
6	73	90	103	146	163	—	—	—
8	143	156	178	225	269	—	—	—
12	345	350	355	403	470	651	—	—
16	542	551	560	623	708	973	1245	1523
20	988	995	1002	1111	1226	1617	2081	2482
25	1462	1480	1498	1638	1785	2314	2845	3437

Note: The weight in the above table is the standard product weight without adjuster.

### Internal Structure

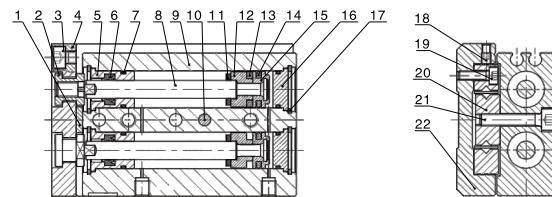

No.	Part Name	Material
1	Cushion Pad	TPU
2	Fixing Screw	Stainless Steel
3	Hexagon Socket Cap Head Screw	Carbon Steel
4	Fixing Plate	Aluminum Alloy
5	Front Cover	Aluminum Alloy
6	Front Scraper Seal	NBR
7	O-ring	NBR
8	Piston Rod	Stainless Steel
9	Barrel	Aluminum Alloy
10	Positioning pin	Stainless Steel
11	Anti-Crash Gasket	TPU
12	Magnet Seat	Aluminum Alloy
13	Integrated Magnet	RbFeB
14	Piston Seal	NBR
15	Piston	Aluminum Alloy
16	Rear Cover	Aluminum Alloy
17	C-Type Retainer Ring	Spring Steel
18	Hexagon Socket Set Screw	Carbon Steel
19	Hexagon Socket Cap Head Screw	Carbon Steel
20	Linear Roller Sliding Guide Rail	Assembly
21	Hexagon Socket Cap Head Screw	Carbon Steel
22	Slide Table	Aluminum Alloy

## Installation and Operation

### 1. How to mount cylinder:

1.1 Cylinder can be mounted from 3 directions.

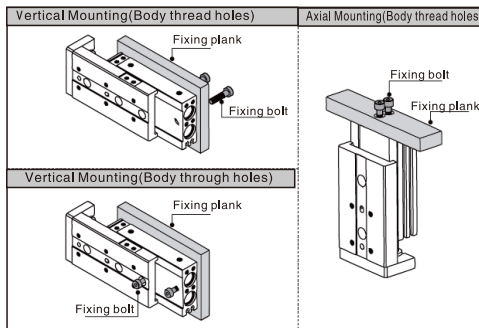

1.2 When mounting an compact slide cylinder, screws of appropriate length should be used and tightened properly within the maximum tightening torque. If screws are tightened beyond designed limits, malfunction may occur. If they are tightened insufficiently, it may result in sliding or falling off from its position.

Vertical Mounting(Body thread holes)	Model	Bolt used	Max.tightening torque (Nm)	Max.screw-in depth l(mm)
	ELS6	M4X0.7	2,1	8
	ELS8	M4X0.7	2,1	8
	ELS12	M5X0.8	4,4	10
	ELS16	M6X1.0	7,4	12
	ELS20	M6X1.0	7,4	12
ELS25	M8X1.25	18	16	
Vertical Mounting(Body through holes)	Model	Bolt used	Max.tightening torque (Nm)	Max.screw-in depth l(mm)
	ELS6	M3X0.5	1,2	10,8
	ELS8	M3X0.5	1,2	12,5
	ELS12	M4X0.7	2,8	18
	ELS16	M5X0.8	5,7	23,5
	ELS20	M5X0.8	5,7	28,5
ELS25	M6X1.0	10	34,5	
Axial Mounting(Body through holes)	Model	Bolt used	Max.tightening torque (Nm)	Max.screw-in depth l(mm)
	ELS6	M2.5X0.45	0,5	3,5
	ELS8	M3X0.5	0,9	4,0
	ELS12	M4X0.7	2,1	6,0
	ELS16	M5X0.8	4,4	7,0
	ELS20	M5X0.8	4,4	8,0
ELS25	M6X1.0	7,4	10,0	

### 2. Work Piece Mounting:

2.1 Work pieces can be mounted on 2 surfaces of the compact slide.

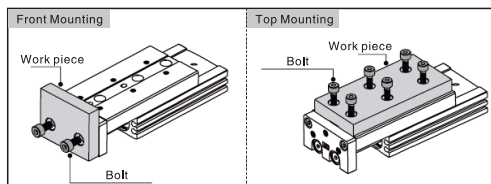

2.2 When mounting a work piece, tighten the bolts properly at a torque value within the limiting range. Use blots at least 0.5mm shorter than maximum thread depth to prevent bolts from contacting the guide block. If the bolts are too long, they hit the guide block and cause damage.

Front Mounting	Model	Bolt used	Max.tightening torque (Nm)	Max.screw-in depth l(mm)
	ELS6	M3X0.5	0,9	5
	ELS8	M4X0.7	2,1	6
	ELS12	M5X0.8	4,4	8
	ELS16	M6X1.0	7,4	10
	ELS20	M6X1.0	7,4	13
ELS25	M8X1.25	18	15	
Top Mounting	Model	Bolt used	Max.tightening torque (Nm)	Max.screw-in depth l(mm)
	ELS6	M3X0.5	0,9	4
	ELS8	M3X0.5	0,9	4,5
	ELS12	M4X0.7	2,1	5,5
	ELS16	M5X0.8	4,4	7,5
	ELS20	M5X0.8	4,4	9,5
ELS25	M6X1.0	7,4	13	

2.3 Since the table is supported by the linear guide, take care not to apply strong impact or large moment to the guide section.

2.4 Hold the slide when fastening work pieces to it with bolts, if the body is held while tightening bolts, excessive moment may damage guide section.

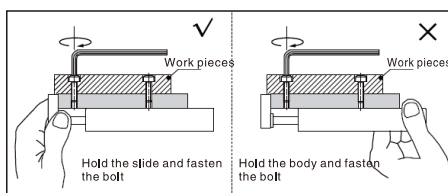

### 3. About shock absorber:

3.1 Shock absorbers are expendable parts. Promptly replace them when energy absorbing capacity decreases.

3.2 Never turn or adjust the screws on bottom of the shock absorber body. The screws are not for adjusting. Otherwise would cause oil leakage.

3.3 Follow the table for tightening torque of shock absorber to lock nuts.

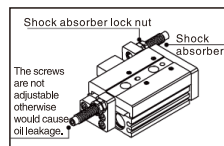

Model	Shock absorber	Tightening torque (Nm)
ELS8	AC0806-WY	1.67
ELS12	AC0806-WY	1.67
ELS16	AC1007-WY	3.14
ELS20	AC1412-WY	10.8
ELS25	AC1412-WY	10.8

### 4. How to mount sensor switch:

4.1 ELS Series are all with magnet.

4.2 Maintain a minimum spacing of at least 3mm if two compact cylinders are used side by side in order to avoid malfunction.

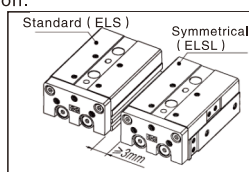

5. Make sure to connect the compact cylinder to speed controller at the meter-out side, and the speed of compact cylinder must be below 500mm/s.

# ELS Series Slide Cylinder



## Main Dimension

ELS 6

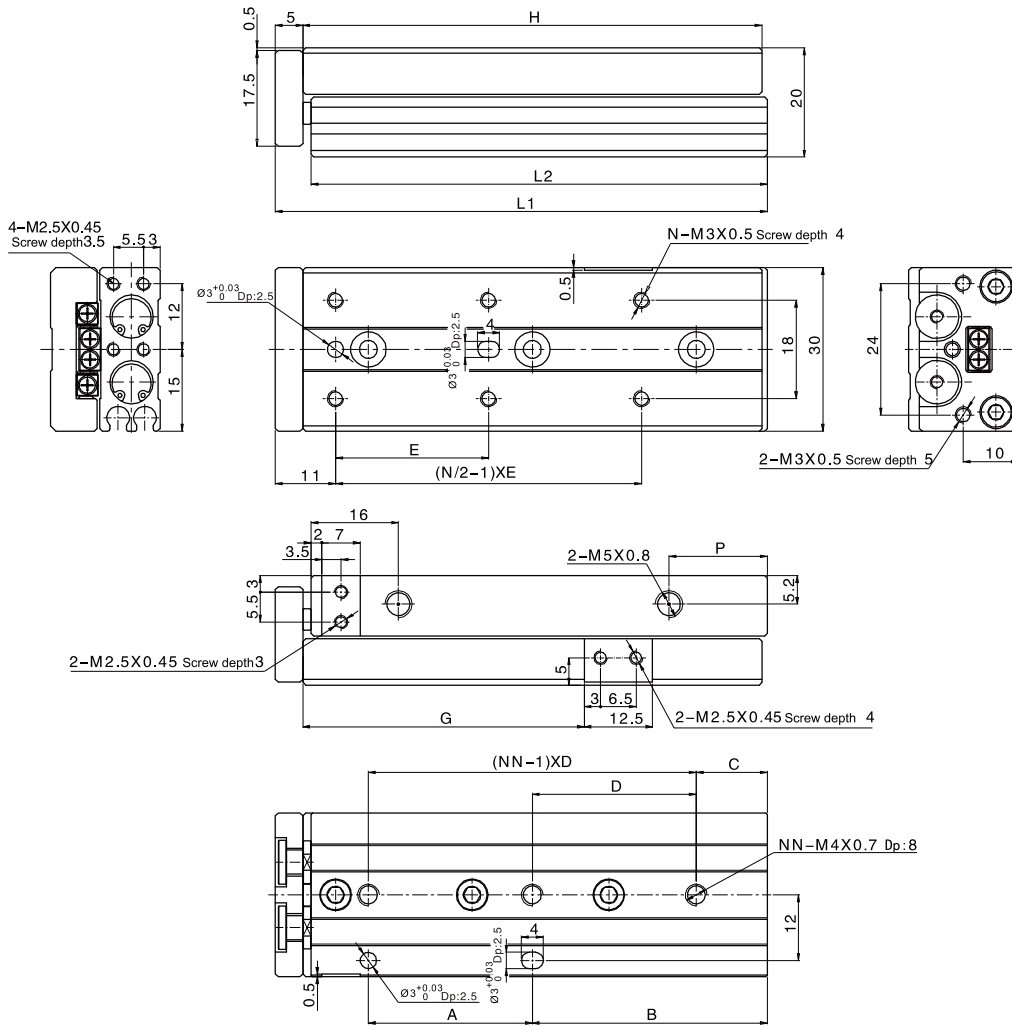

Storke/Sign	A	B	C	D	E	G	H	P	L1	L2	N	NN
10	20	11	6	25	20	21.5	42	9.5	48	41.5	4	2
20	20	21	6	35	30	31.5	52	9.5	58	51.5	4	2
30	20	31	11	20	20	41.5	62	8	68	61.5	6	3
40	30	43	13	30	28	51.5	84	18	90	83.5	6	3
50	48	41	17	24	38	61.5	100	24	106	99.5	6	4

## Main Dimension

ELS 8

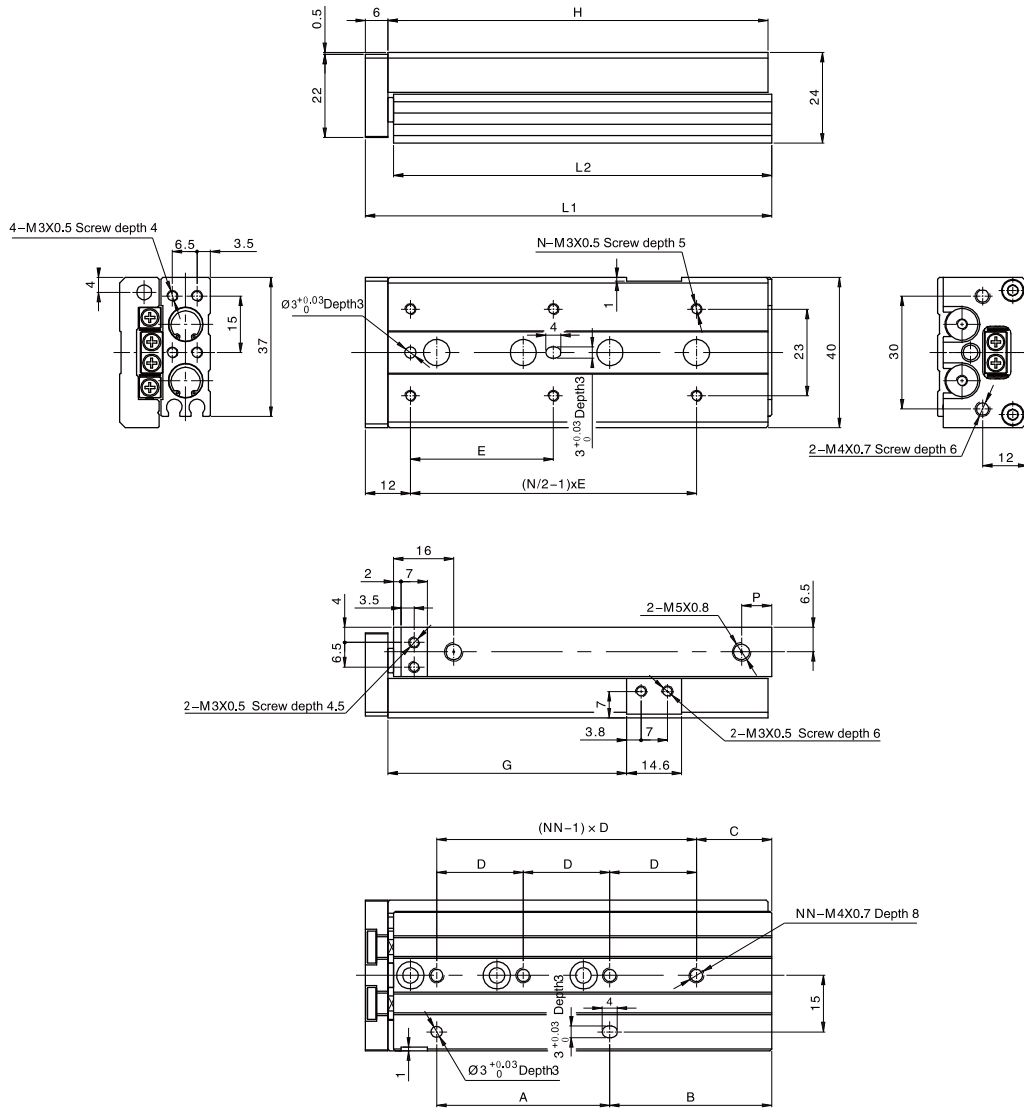

Stroke/Sign	A	B	C	D	E	G	H	P	L1	L2	N	NN
10	20	17	9	28	25	23.5	49	13	56	48.5	4	2
20	30	12	12	30	25	33.5	54	8	61	53.5	4	2
30	20	33	13	20	40	43.5	65	8	72	64.5	4	3
40	28	43	15	28	50	53.5	83	8	90	82.5	4	3
50	46	43	20	23	38	63.5	101	8	108	100.5	6	4
75	56	83	27	28	50	88.5	151	8	158	150.5	6	5

# ELS Series Slide Cylinder



## Main Dimension

ELS 12

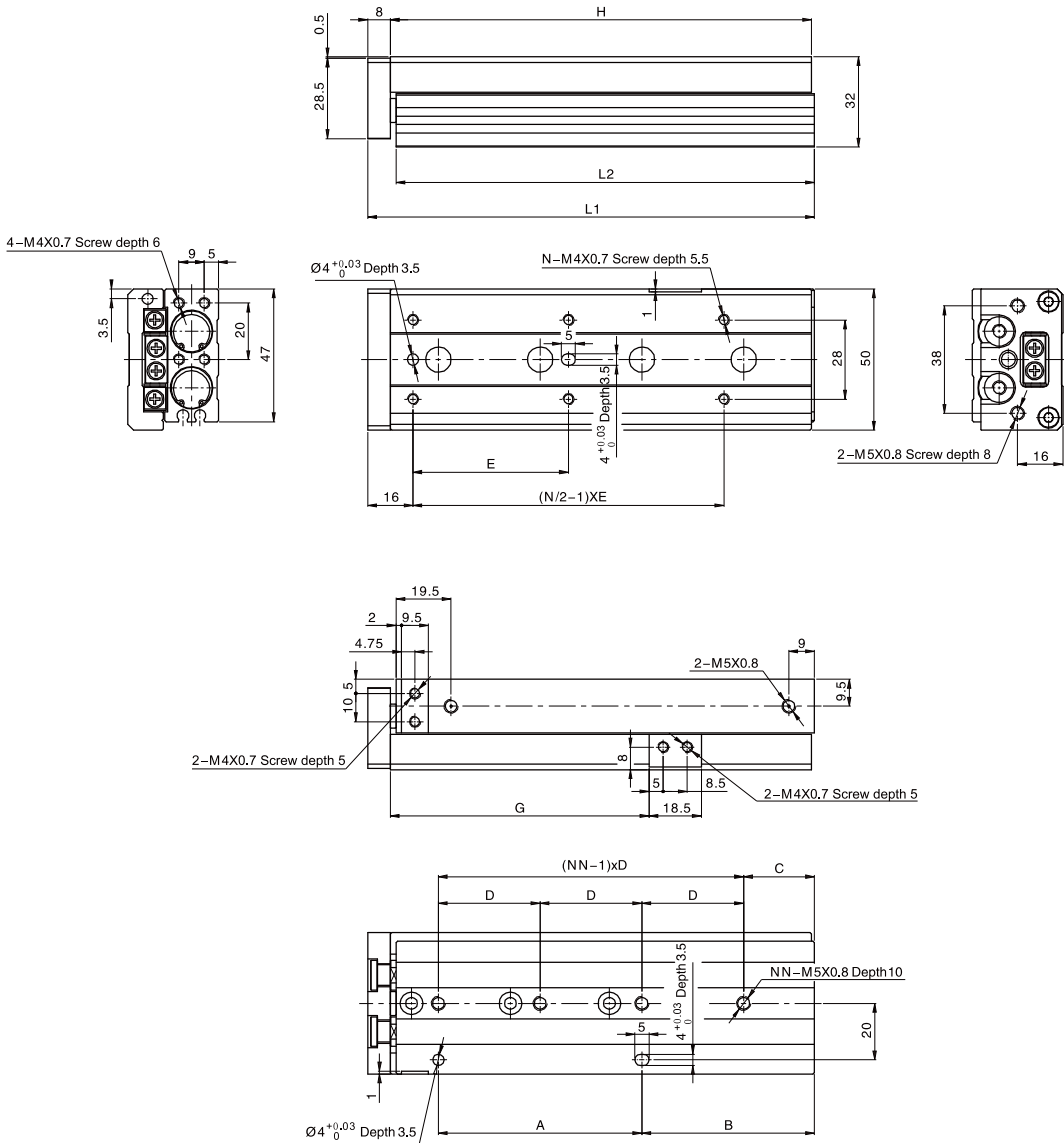

Stroke/Sign	A	B	C	D	E	G	H	L1	L2	N	NN
10	40	15	15	40	35	26.5	71	80	70	4	2
20	40	15	15	40	35	36.5	71	80	70	4	2
30	40	15	15	40	35	46.5	71	80	70	4	2
40	25	42	17	25	50	56.5	83	92	82	4	3
50	36	51	15	36	35	66.5	103	112	102	6	3
75	72	61	25	36	55	91.5	149	158	148	6	4
100	76	111	35	38	65	116.5	203	212	202	6	5

## Main Dimension

ELS 16

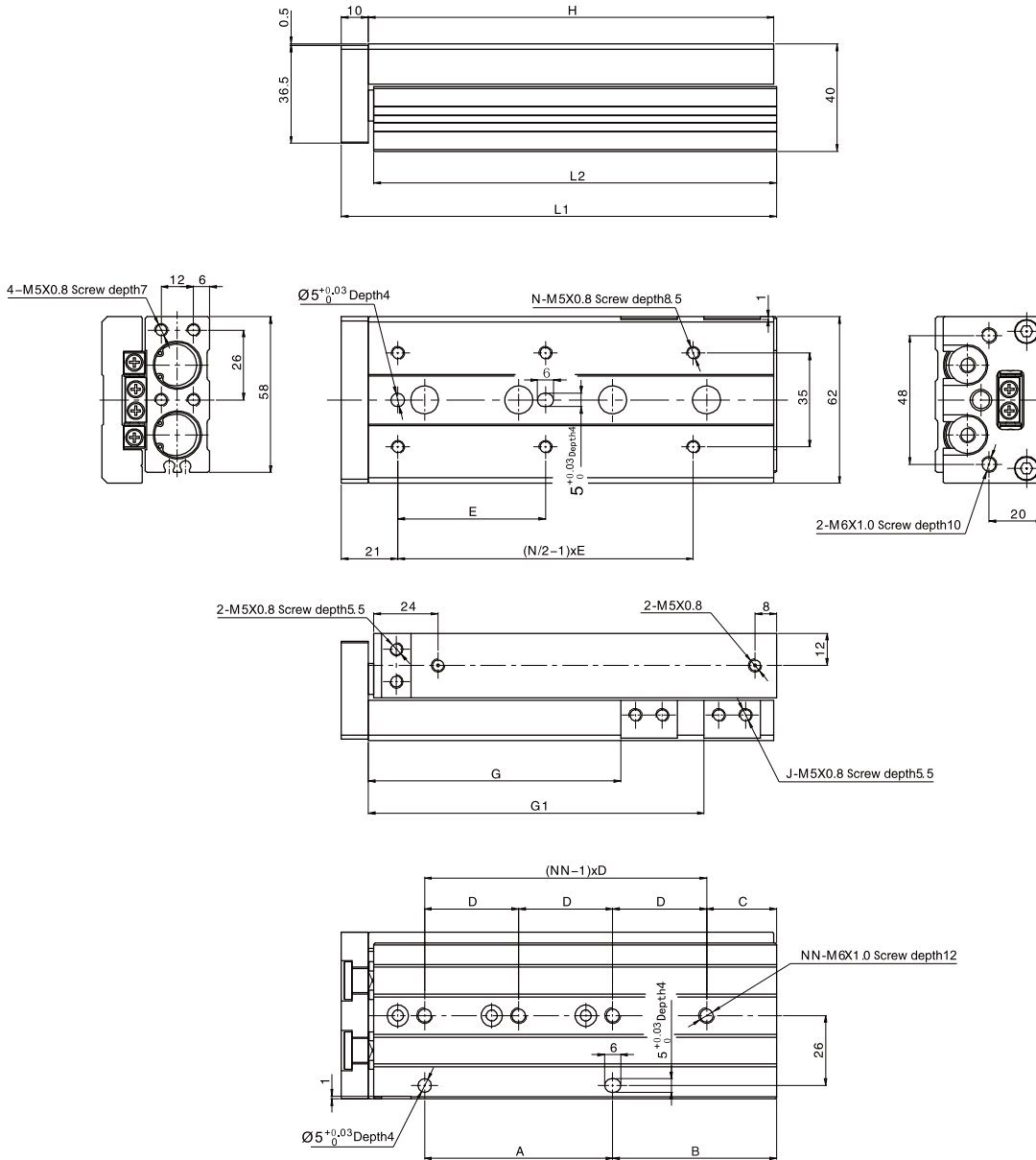

Stroke/Sign	A	B	C	D	E	G	H	L1	L2	N	NN
10	40	16	16	40	35	29	76	87	75	4	2
20	40	16	16	40	35	39	76	87	75	4	2
30	40	16	16	40	35	49	76	87	75	4	2
40	50	16	16	50	40	59	86	97	85	4	2
50	30	51	21	30	30	69	101	112	100	6	3
75	70	61	26	35	55	94	151	162	150	6	4
100	70	109	39	35	65	119	199	210	198	6	5
125	70	159	19	35	70	144	249	260	248	8	7

# ELS Series Slide Cylinder



## Main Dimension

ELS 20

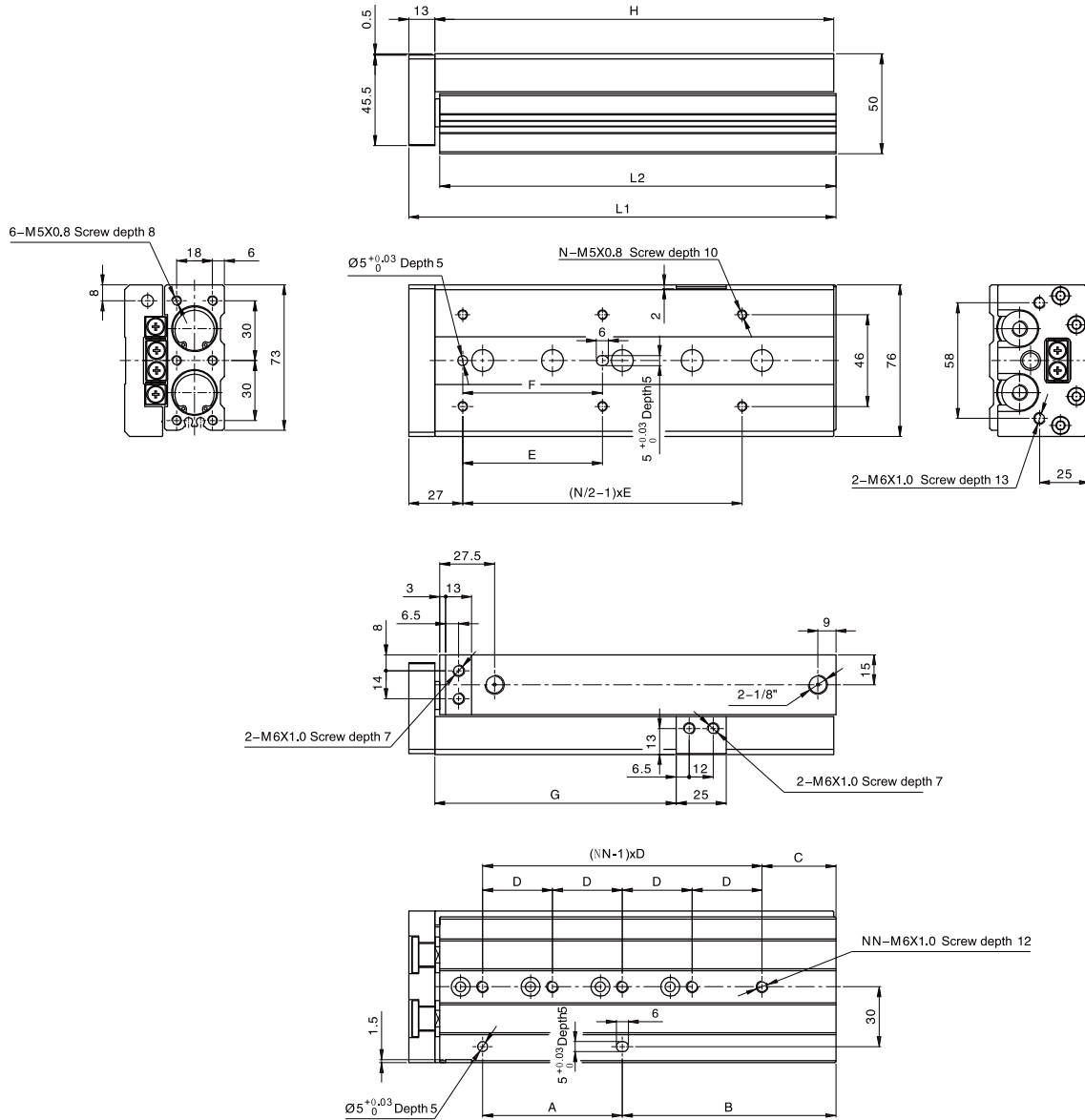

Storke/Sign	A	B	C	D	E	F	G	H	L1	L2	N	NN
10	35	25	15	45	50	40	31	83	97	81.5	4	2
20	35	25	15	45	50	40	41	83	97	81.5	4	2
30	35	25	15	45	50	40	51	83	97	81.5	4	2
40	35	35	15	55	60	50	61	93	107	91.5	4	2
50	35	50	15	35	35	35	71	108	122	106.5	6	3
75	70	54	19	35	60	60	96	147	161	145.5	6	4
100	70	107	37	35	70	70	121	200	214	198.5	6	5
125	76	155	41	38	70	70	146	254	268	252.5	8	6
150	88	195	19	44	80	80	171	306	320	304.5	8	7

## Main Dimension

ELS 25

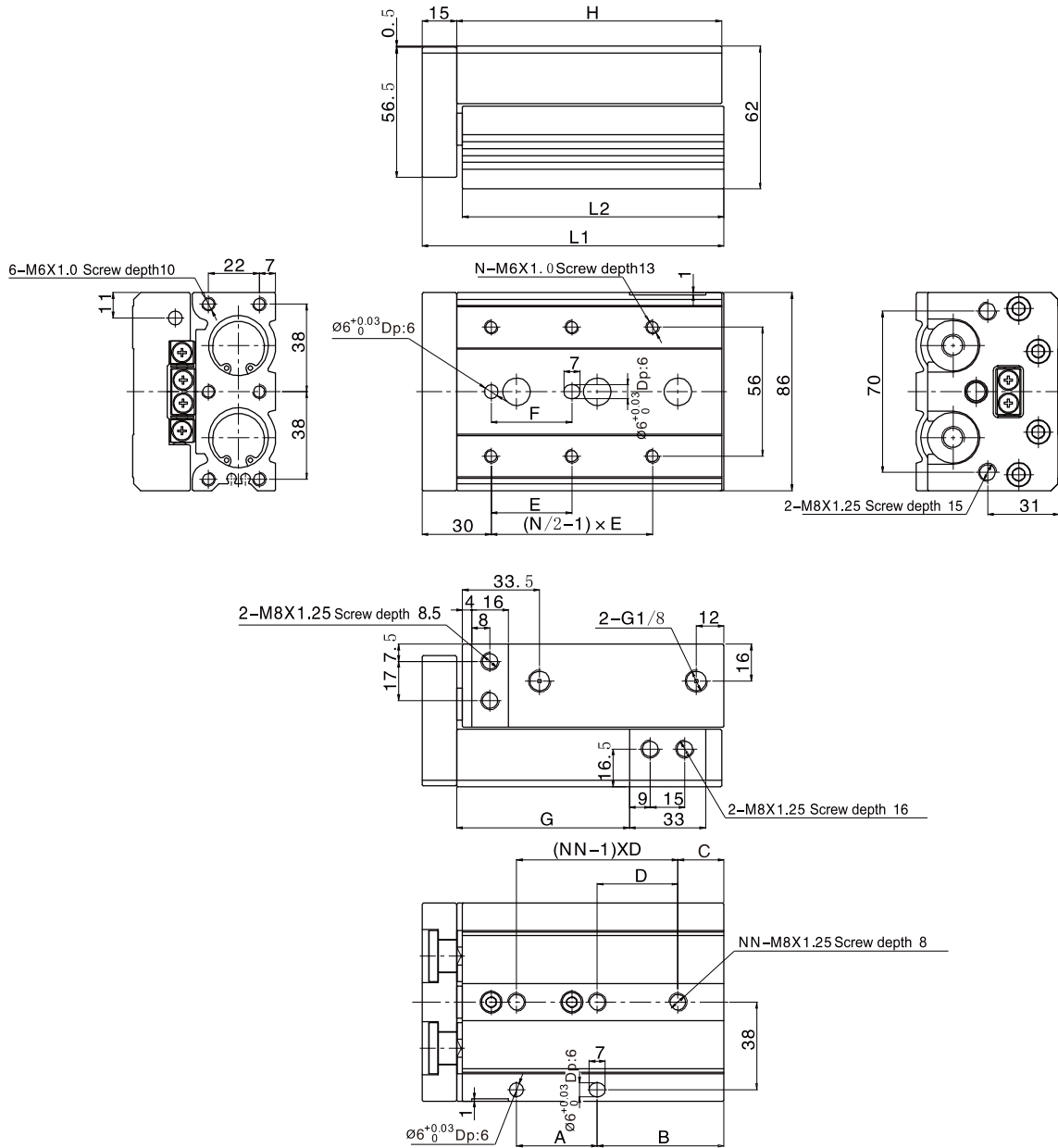

Stroke/Sign	A	B	C	D	E	F	G	H	L1	L2	N	NN
10	45	22	22	45	50	40	35	92	108	90.5	4	2
20	45	22	22	45	50	40	45	92	108	90.5	4	2
30	45	22	22	45	50	40	55	92	108	90.5	4	2
40	55	22	22	55	60	50	65	102	118	100.5	4	2
50	35	55	20	35	35	35	75	115	131	113.5	6	3
75	70	61	26	35	60	60	100	156	172	154.5	6	4
100	70	102	32	35	70	70	125	197	213	195.5	6	5
125	76	154	40	38	75	75	150	255	271	253.5	8	6
150	80	190	30	40	80	80	175	295	311	293.5	8	7

# ELS Series Slide Cylinder



## How to Order (for accessories)

FJ - ELS 20 AF

Series No. Type Bore Accessory Type

- A: With stroke adjusting screws at both ends
- AS: With stroke adjusting screws at extension end
- AF: With stroke adjusting screws at retraction end
- B: With shock absorbers both end
- BS: With shock absorber at extension end
- BF: With shock absorber at retraction end

## Optional Accessories

Accessory type/Bore		6	8	12	16	20	25
Both end	A (stroke adjusting screw)	FJ-ELS6	FJ-ELS8A	FJ-ELS12A	FJ-ELS16A	FJ-ELS20A	FJ-ELS25A
	B (shock absorber)		FJ-ELS8B	FJ-ELS12B	FJ-ELS16B	FJ-ELS20B	FJ-ELS25B
Extension end	AS (stroke adjusting screw)	FJ-ELS6AS	FJ-ELS8AS	FJ-ELS12AS	FJ-ELS16AS	FJ-ELS20AS	FJ-ELS25AS
	BS (shock absorber)		FJ-ELS8BS	FJ-ELS12BS	FJ-ELS16BS	FJ-ELS20BS	FJ-ELS25BS
Retraction end	AF (stroke adjusting screw)	FJ-ELS6AF	FJ-ELS8AF	FJ-ELS12AF	FJ-ELS16AF	FJ-ELS20AF	FJ-ELS25AF
	BF (shock absorber)		FJ-ELS8BF	FJ-ELS12BF	FJ-ELS16BF	FJ-ELS20BF	FJ-ELS25BF

Note: A=AS+AF; B=BS+BF

## Dimension for Accessories

### AS (With stroke adjusting screws at extension end)

Accessory on the body

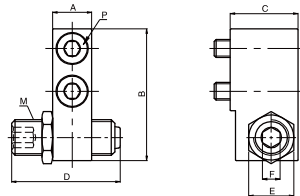

Accessory on the slide

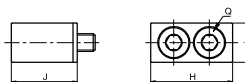

Bore/Sign	Adjustable stroke range	A	B	C	D	E	F	M	P	H	I	J	Q
6	10	7	19	10.5	22.5	8	3	M6X1.0	M2.5 Length 10	12.5	6.5	10.5	M2.5 Length 10
8	10	7	23	15.5	27.5	11	4	M8X1.0	M3 Length 16	16.6	7	15.5	M3 Length 16
12	10	9.5	31	16	27.5	11	4	M8X1.0	M4 Length 14	20.5	9	15	M4 Length 14
16	10	11	37	19	30.5	12.7	5	M10X1.0	M5 Length 18	23	11	18.5	M5 Length 18
20	10	13	47	26	34	19	6	M14X1.5	M6 Length 25	27	12	25.5	M6 Length 25
25	10	16	54	24	34	19	6	M14X1.5	M8 Length 20	33	17	23	M8 Length 20

### BS (With shock absorber at extension end)

Accessory on the body

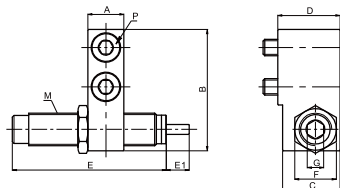

Accessory on the slide

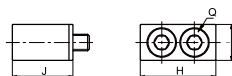

Bore/Sign	A	B	C	D	E	E1	F	M	P	H	I	J	Q
8	7	23	14	15.5	38	6	11	M8X1.0	M3 Length 16	16.6	7	15.5	M3 Length 16
12	9.5	31	14.5	16	38	6	11	M8X1.0	M4 Length 14	20.5	9	15	M4 Length 14
16	11	37	17.5	19	43	7	12.7	M10X1.0	M5 Length 18	23	11	18.5	M5 Length 18
20	13	47	23.5	26	76	12	19	M14X1.5	M6 Length 25	27	12	25.5	M6 Length 25
25	16	54	22	24	76	12	19	M14X1.5	M8 Length 20	33	17	23	M8 Length 20

## Main Dimension

### AF (With stroke adjusting screws at retraction end)

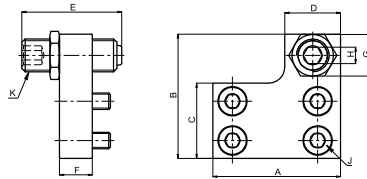

Bore/Sign	Adjustable stroke range	A	B	C	D	E	F	G	H	J	K
6	10	18	19	11.2	8	22.5	6	8	3	M2.5 Length 6	M6X1.0
8	10	25	23.2	13.2	15	27.5	8	11	4	M3 Length 8	M8X1.0
12	10	32	31	18.5	13	27.5	8	11	4	M4 Length 8	M8X1.0
16	10	39	38	23	17	30.5	10	12.7	5	M5 Length 10	M10X1.0
20	10	48	48	29	20.5	34	12	19	6	M5 Length 12	M14X1.5
25	10	51	53.5	34	25	34	15	19	6	M6 Length 16	M14X1.5

### BF (With shock absorber at retraction end)

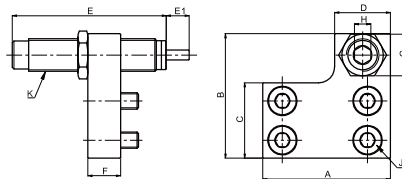

Bore/Sign	A	B	C	D	E	E1	F	G	J	K
8	25	23.2	13.2	15	38	6	8	11	M3 Length 8	M8X1.0
12	32	31	18.5	13	38	6	8	11	M4 Length 8	M8X1.0
16	39	38	23	17	43	7	10	12.7	M5 Length 10	M10X1.0
20	48	48	29	20.5	76	12	12	19	M5 Length 12	M14X1.5
25	51	53.5	34	25	76	12	15	19	M6 Length 16	M14X1.5

# ELQ Series Slide Cylinder



## ELQ

Slide Cylinder



### Specifications

Bore(mm)	6	8	12	16	20	25
Acting Type	Double Acting					
Working Medium	Clean Air(after 40 μm filtration)					
Working Pressure(MPa)	0.15-0.7					
Guaranteed Pressure(MPa)	1.05					
Working Temperature(°C)	-20~80(No freezing)					
Piston Speed(mm/s)	50~500					
Stroke tolerance	Stroke ≤ 100 <sup>+1.0</sup> <sub>0</sub> , Stroke > 100 <sup>+1.5</sup> <sub>0</sub>					
Cushion	Rubber cushion on both ends, Shock absorber cushion					
Port Size	M5x0.8			G1/8		

### How to order?

Series No.	Bore X	Stroke	Magnet No.	Adjuster	Thread Type
ELQ	6 8 12 16 20 25	Details in stroke chart	S: With magnet	Blank: None adjuster A: Adjusters on both ends AS: Forward adjuster AF: Backward adjuster B: Shock absorber on both ends BS: Forward shock absorber BF: Backward shock absorber	Blank: G

#### Order Example:

ELQ Series Basic type cylinder, bore size 20, stroke 50, with Magnet, without adjuster, thread type G. The ERP code is: ELQ20X50-S

### Optional Accessories

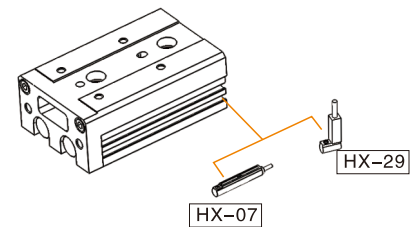

Note: Short stroke please use HX-29 series due to limited space.

### Stroke

Bore(mm)	Standard Stroke(mm)								Max.Stroke(mm)	
Double Acting	6	10	20	30	40	50			50	
	8	10	20	30	40	50			50	
	12	10	20	30	40	50	75		75	
	16	10	20	30	40	50	75	100	125	125
	20	10	20	30	40	50	75	100	125	125
25	10	20	30	40	50	75	100	125	125	

### Weight(g)

Bore(mm)	Stroke(mm)							
	10	20	30	40	50	75	100	125
6	73	90	103	131	149	—	—	—
8	129	151	175	211	261	—	—	—
12	303	307	354	412	461	614	—	—
16	505	514	558	622	713	889	1104	1266
20	912	923	934	1042	1155	1475	1906	2098
25	1402	1420	1438	1562	1782	2123	2571	3053

Note: The weight in the above table is the standard product weight without adjuster.

### Internal Structure

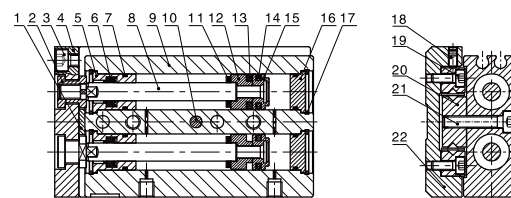

No.	Part Name	Material
1	Cushion Pad	TPU
2	Fixing Screw	Stainless Steel
3	Hexagon Socket Cap Head Screw	Carbon Steel
4	Fixing Plate	Aluminum Alloy
5	Front Cover	Aluminum Alloy
6	Front Scraper Seal	NBR
7	O-ring	NBR
8	Piston Rod	Stainless Steel
9	Barrel	Aluminum Alloy
10	Positioning pin	Stainless Steel
11	Anti-Crash Gasket	TPU
12	Magnet Seat	Aluminum Alloy
13	Integrated Magnet	RbFeB
14	Piston Seal	NBR
15	Piston	Aluminum Alloy
16	Rear Cover	Aluminum Alloy
17	C-Type Retainer Ring	Spring Steel
18	Hexagon Socket Set Screw	Carbon Steel
19	Hexagon Socket Cap Head Screw	Carbon Steel
20	Linear Roller Sliding Guide Rail	Assembly
21	Hexagon Socket Cap Head Screw	Carbon Steel
22	Slide Table	Aluminum Alloy

## Installation and Operation

### 1. How to mount cylinder:

1.1 Cylinder can be mounted from 3 directions.

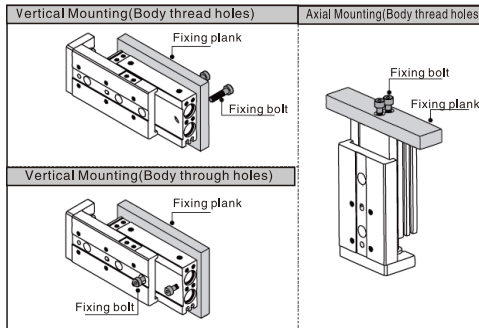

1.2 When mounting an compact slide cylinder, screws of appropriate length should be used and tightened properly within the maximum tightening torque. If screws are tightened beyond designed limits, malfunction may occur. If they are tightened insufficiently, it may result in sliding or falling off from its position.

Vertical Mounting(Body thread holes)	Model	Bolt used	Max.tightening torque (Nm)	Max.screw-in depth l(mm)
	ELQ6	M4X0.7	2,1	8
	ELQ8	M4X0.7	2,1	8
	ELQ12	M5X0.8	4,4	10
	ELQ16	M6X1.0	7,4	12
	ELQ20	M6X1.0	7,4	12
	ELQ25	M8X1.25	18	16

Vertical Mounting(Body through holes)	Model	Bolt used	Max.tightening torque (Nm)	Max.screw-in depth l(mm)
	ELQ6	M3X0.5	1,2	10,8
	ELQ8	M3X0.5	1,2	12
	ELQ12	M4X0.7	2,8	13,5
	ELQ16	M5X0.8	5,7	16,5
	ELQ20	M5X0.8	5,7	22
	ELQ25	M6X1.0	10	28

Axial Mounting(Body through holes)	Model	Bolt used	Max.tightening torque (Nm)	Max.screw-in depth l(mm)
	ELQ6	M2.5X0.45	0,5	3,5
	ELQ8	M3X0.5	0,9	4,0
	ELQ12	M4X0.7	2,1	6,0
	ELQ16	M5X0.8	4,4	7,0
	ELQ20	M5X0.8	4,4	8,0
	ELQ25	M6X1.0	7,4	10,0

### 2. Work Piece Mounting:

2.1 Work pieces can be mounted on 2 surfaces of the compact slide.

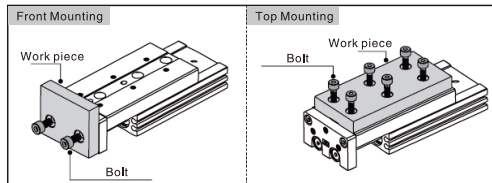

2.2 When mounting a work piece, tighten the bolts properly at a torque value within the limiting range. Use blots at least 0.5mm shorter than maximum thread depth to prevent bolts from contacting the guide block. If the bolts are too long, they hit the guide block and cause damage.

Front Mounting	Model	Bolt used	Max.tightening torque (Nm)	Max.screw-in depth l(mm)
	ELQ6	M3X0.5	0,9	5
	ELQ8	M4X0.7	2,1	6
	ELQ12	M5X0.8	4,4	8
	ELQ16	M6X1.0	7,4	10
	ELQ20	M6X1.0	7,4	13
	ELQ25	M8X1.25	18	15

Top Mounting	Model	Bolt used	Max.tightening torque (Nm)	Max.screw-in depth l(mm)
	ELQ6	M3X0.5	0,9	4
	ELQ8	M3X0.5	0,9	4,5
	ELQ12	M4X0.7	2,1	5,5
	ELQ16	M5X0.8	4,4	7,5
	ELQ20	M5X0.8	4,4	9,5
	ELQ25	M6X1.0	7,4	13

2.3 Since the table is supported by the linear guide, take care not to apply strong impact or large moment to the guide section.

2.4 Hold the slide when fastening work pieces to it with bolts, if the body is held while tightening bolts, excessive moment may damage guide section.

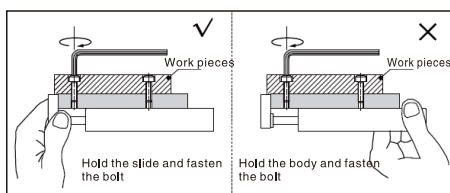

### 3. About shock absorber:

3.1 Shock absorbers are expendable parts. Promptly replace them when energy absorbing capacity decreases.

3.2 Never turn or adjust the screws on bottom of the shock absorber body. The screws are not for adjusting. Otherwise would cause oil leakage.

3.3 Follow the table for tightening torque of shock absorber to lock nuts.

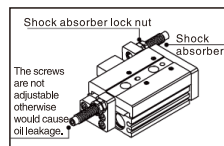

Model	Shock absorber	Tightening torque (Nm)
ELQ8	AC0806-WY	1.67
ELQ12	AC0806-WY	1.67
ELQ16	AC1007-WY	3.14
ELQ20	AC1412-WY	10.8
ELQ25	AC1412-WY	10.8

### 4. How to mount sensor switch:

4.1 ELQ Series are all with magnet.

4.2 Maintain a minimum spacing of at least 3mm if two compact cylinders are used side by side in order to avoid malfunction.

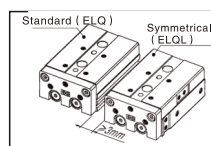

5. Make sure to connect the compact cylinder to speed controller at the meter-out side, and the speed of compact cylinder must be below 500mm/s.

# ELQ Series Slide Cylinder



## Main Dimensions

ELQ 6

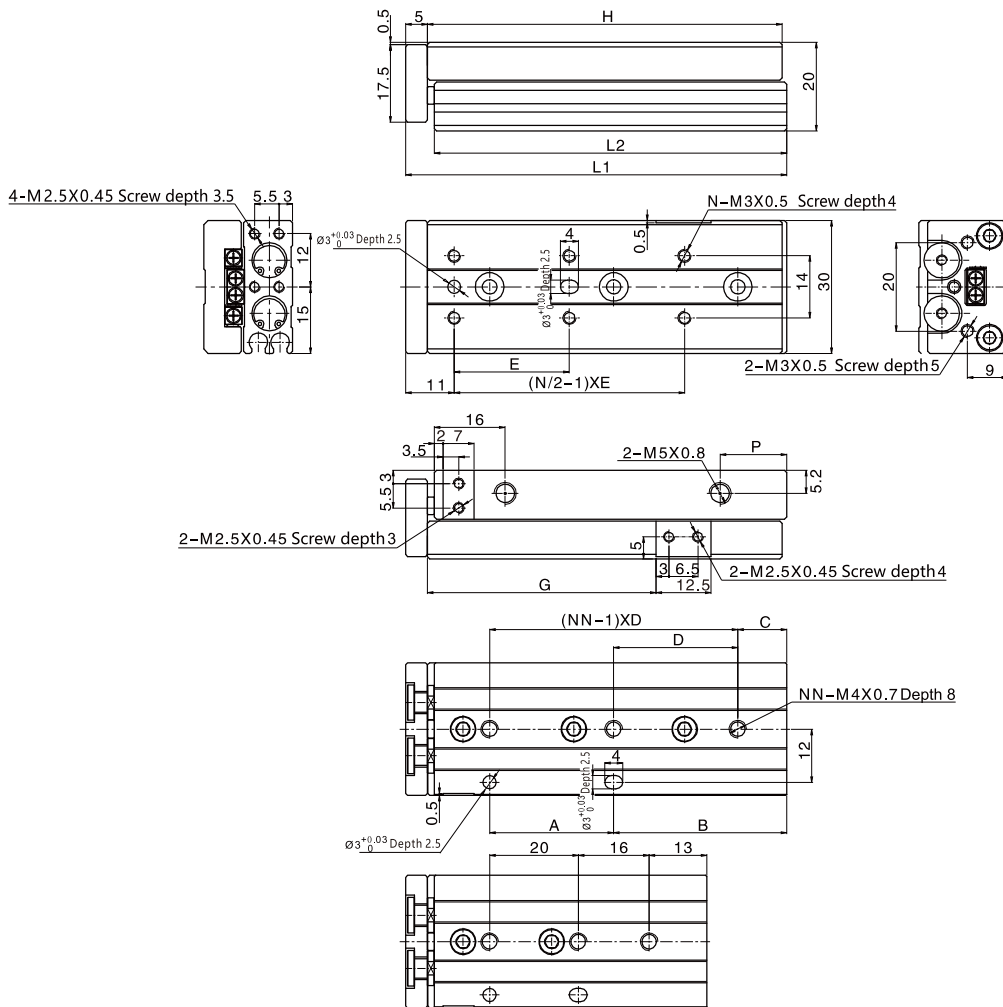

ELQ 6x30

Stroke/Sign	A	B	C	D	E	G	H	P	L1	L2	N	NN
10	16	13	6	23	22	21.5	42	9.5	48	41.5	4	2
20	26	13	13	26	25	31.5	52	9	58	51.5	4	2
30	20	29	See drawing	See drawing	21	41.5	62	9	68	61.5	6	3
40	28	39	11	28	26	51.5	80	15	86	79.5	6	3
50	28	49	21	28	27	61.5	90	15	96	89.5	6	3



# ELQ Series Slide Cylinder



## ☉ Main Dimensions

ELQ 12

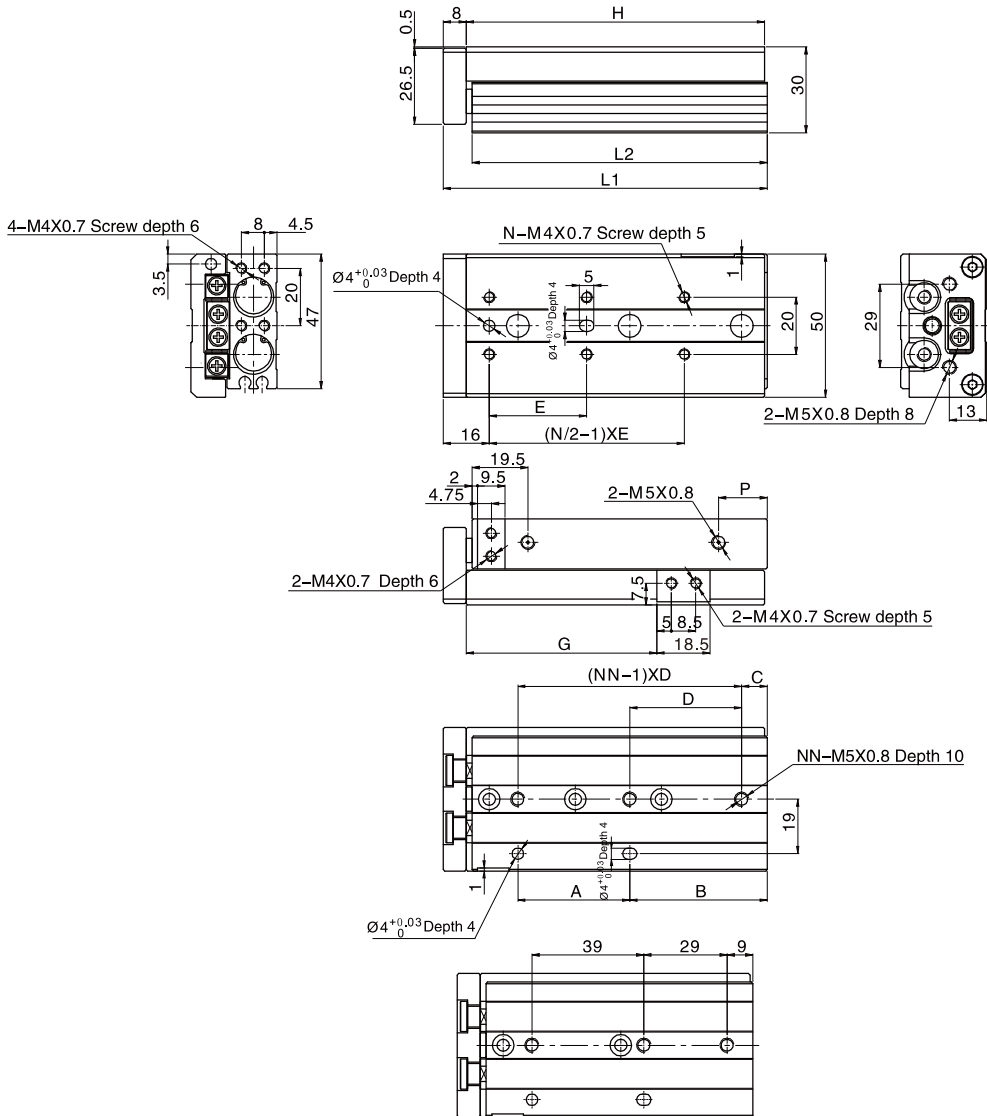

ELQ12x40

Stroke/Sign	A	B	C	D	E	G	H	L1	L2	N	NN
10	32	18	18	32	28	26.5	67	76	66	4	2
20	32	18	18	32	28	36.5	67	76	66	4	2
30	40	20	20	40	38	46.5	77	86	76	4	2
40	39	38	See drawing	See drawing	34	56.5	94	103	93	6	3
50	39	48	9	39	34	66.5	104	113	103	6	3
75	72	59	23	36	36	91.5	148	157	147	8	4
100	72	84	12	36	36	116.5	173	182	172	10	5

## Main Dimensions

ELQ 16

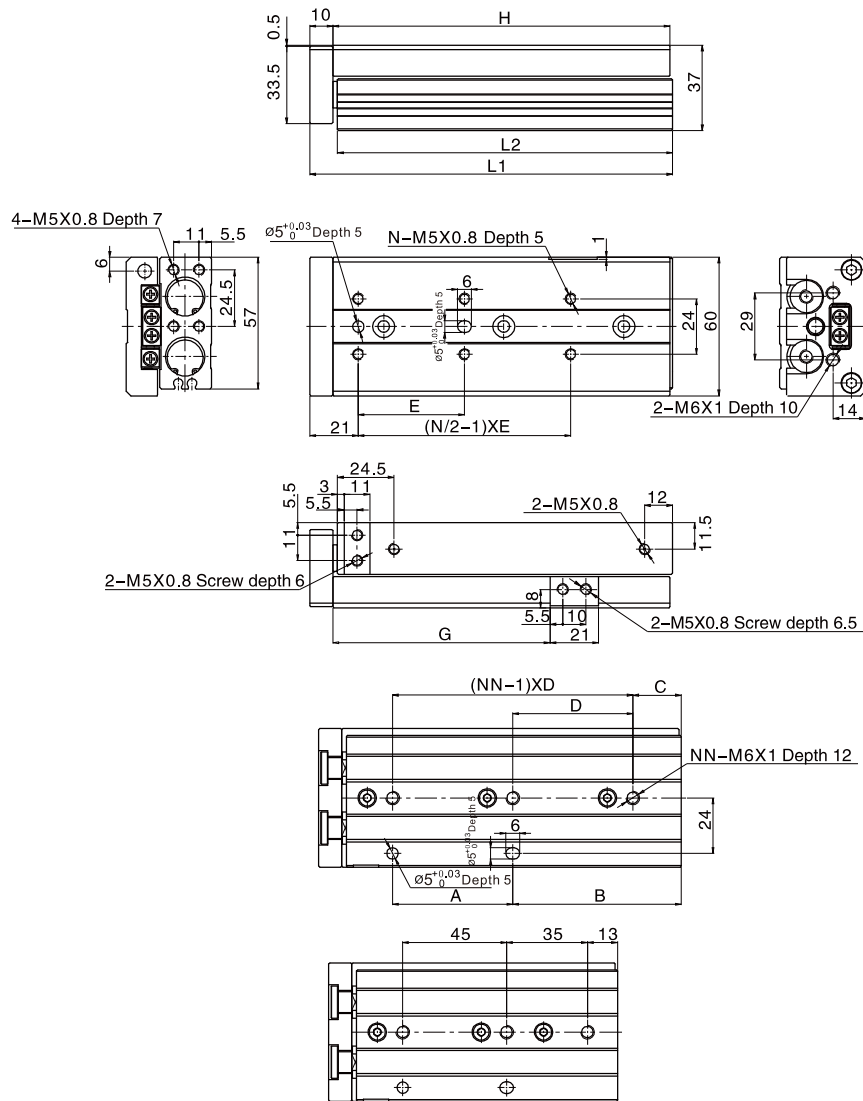

ELQ16x50

Stroke/Sign	A	B	C	D	E	G	H	L1	L2	N	NN
10	39	18	18	39	38	29	78	89	77	4	2
20	39	18	18	39	38	39	78	89	77	4	2
30	48	19	19	48	48	49	88	99	87	4	2
40	58	19	19	58	58	59	98	109	97	4	2
50	45	48	See drawing	See drawing	40	69	114	125	113	6	3
75	52	73	21	52	46	94	146	157	145	6	3
100	88	80	36	44	44	119	189	200	188	8	4
125	88	105	17	44	44	144	214	225	213	10	5

# ELQ Series Slide Cylinder



## Main Dimensions

ELQ 20

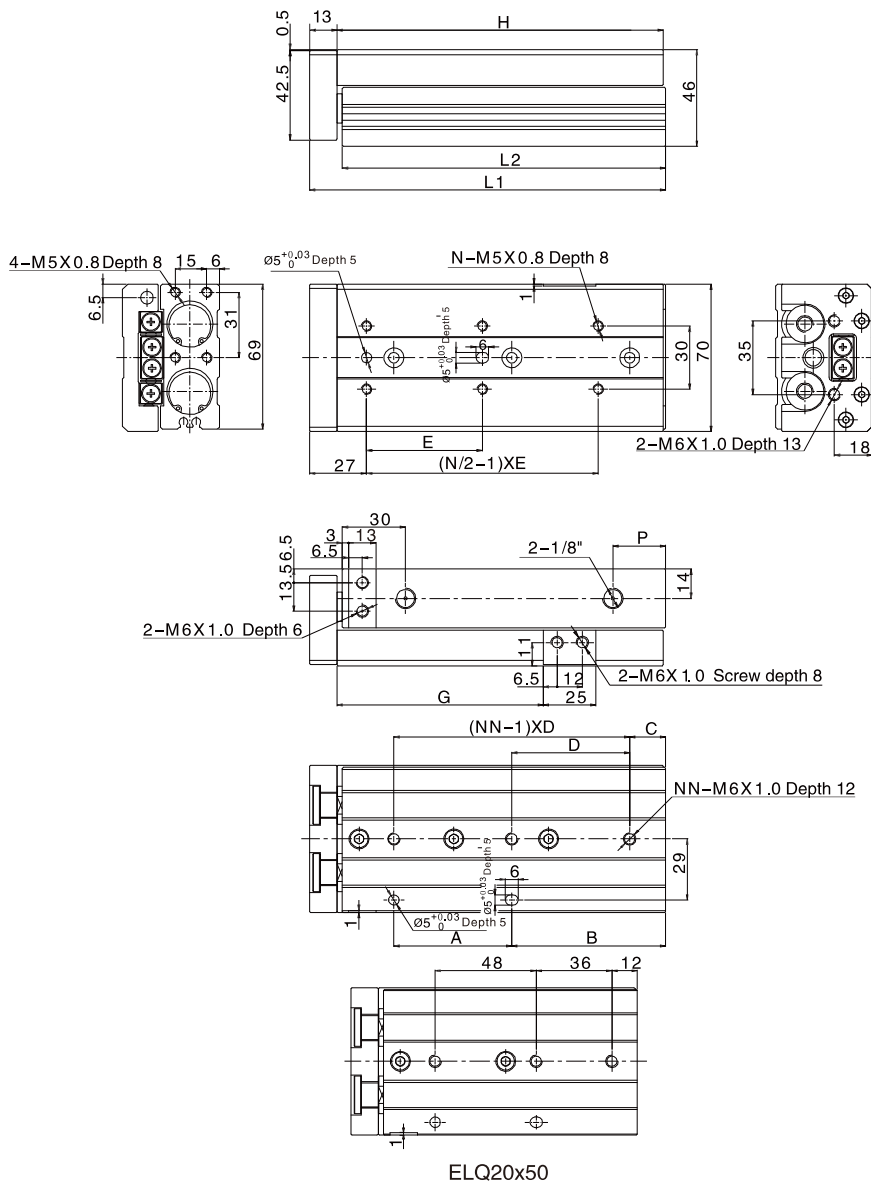

Stroke/Sign	A	B	C	D	E	P	G	H	L1	L2	N	NN
10	50	18	22	46	45	16	31	94	108	92.5	4	2
20	50	18	22	46	40	16	41	94	108	92.5	4	2
30	50	18	22	46	48	16	51	94	108	92.5	4	2
40	56	22	22	56	58	16	61	104	118	102.5	4	2
50	48	48	See drawing	See drawing	42	18	71	122	136	120.5	6	3
75	56	73	17	56	55	25	96	155	169	153.5	6	3
100	112	74	18	56	50	25	121	212	226	210.5	8	4
125	118	96	37	59	55	25	146	240	254	238.5	8	4
150	124	118	56	62	62	25	171	268	282	266.5	8	4

## Main Dimensions

ELQ 25

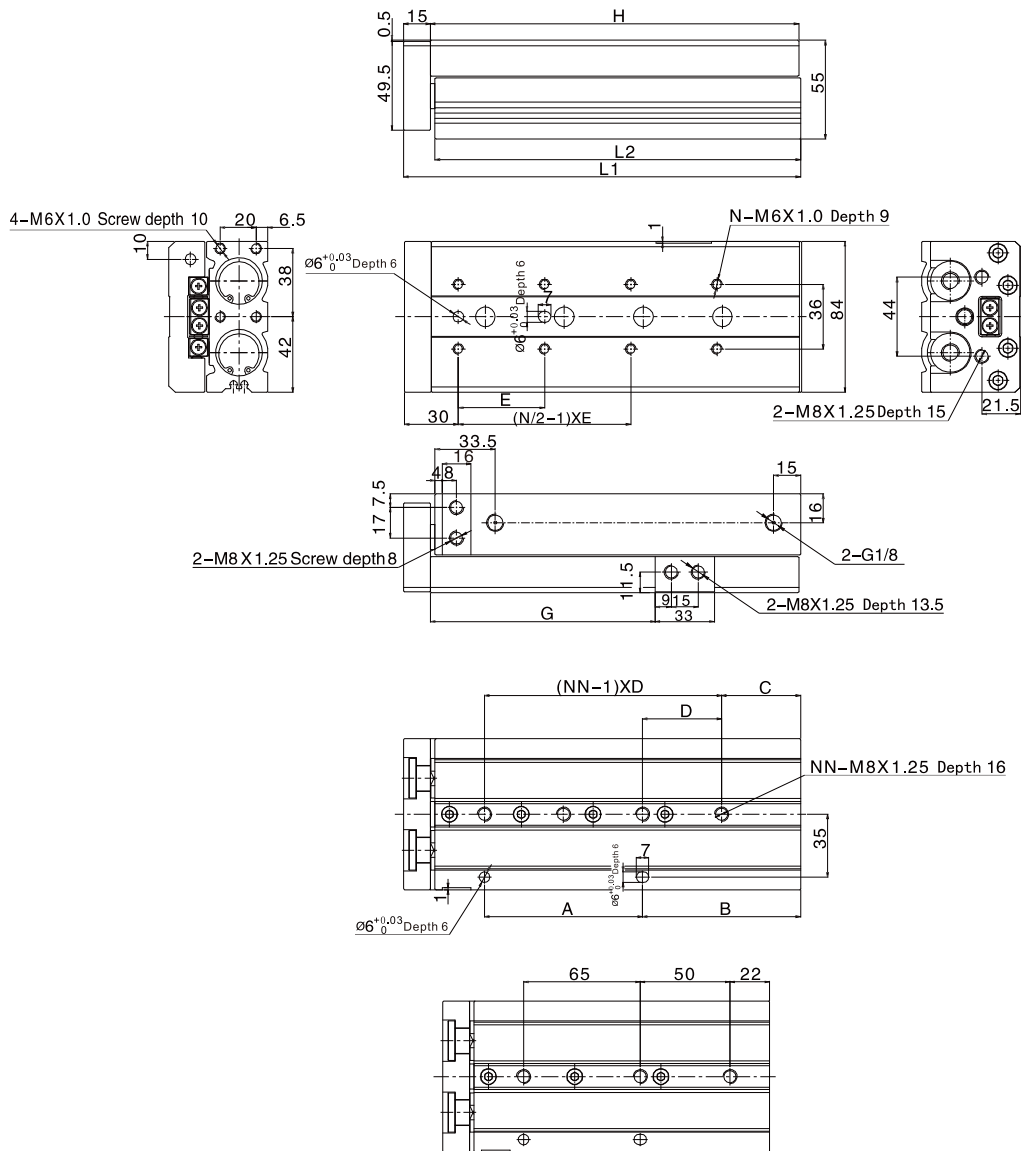

ELQ25x75

Stroke/Sign	A	B	C	D	E	G	H	L1	L2	N	NN
10	55	23	23	55	55	35	107	123	105.5	4	2
20	55	23	23	55	46	45	107	123	105.5	4	2
30	55	23	23	55	55	55	107	123	105.5	4	2
40	65	23	23	65	65	65	117	133	115.5	4	2
50	80	32	32	80	75	75	141	157	139.5	4	2
75	65	72	See drawing	See drawing	60	100	166	182	164.5	6	3
100	88	88	44	44	48	125	205	221	203.5	8	4
125	132	97	31	66	60	150	258	274	256.5	8	4
150	132	122	56	66	65	175	283	299	281.5	8	4

# ELQ Series Slide Cylinder



## How to Order (for accessories)

FJ	-	ELQ	20	AF
Series No.		Type	Bore	Accessory Type

- A: With stroke adjusting screws at both ends
- AS: With stroke adjusting screws at extension end
- AF: With stroke adjusting screws at retraction end
- B: With shock absorbers both end
- BS: With shock absorber at extension end
- BF: With shock absorber at retraction end

## Optional Accessories

Accessory type/Bore		6	8	12	16	20	25
Both end	A (stroke adjusting screw)	FJ-ELS6A	FJ-ELQ 8A	FJ-ELQ 12A	FJ-ELQ 16A	FJ-ELQ 20A	FJ-ELS 25A
	B (shock absorber)		FJ-ELQ 8B	FJ-ELQ 12B	FJ-ELQ 16B	FJ-ELQ 20B	FJ-ELS 25B
Extension end	AS (stroke adjusting screw)	FJ-ELS 6AS	FJ-ELQ 8AS	FJ-ELQ 12AS	FJ-ELQ 16AS	FJ-ELQ 20AS	FJ-ELS 25AS
	BS (shock absorber)		FJ-ELQ 8BS	FJ-ELQ 12BS	FJ-ELQ 16BS	FJ-ELQ 20BS	FJ-ELS 25BS
Retraction end	AF (stroke adjusting screw)	FJ-ELS6AF	FJ-ELQ 8AF	FJ-ELQ 12AF	FJ-ELQ 16AF	FJ-ELQ 20AF	FJ-ELS 25AF
	BF (shock absorber)		FJ-ELQ 8BF	FJ-ELQ 12BF	FJ-ELQ 16BF	FJ-ELQ 20BF	FJ-ELS 25BF

Note: A=AS+AF; B=BS+BF

## Dimension for Accessories

### AS (With stroke adjusting screws at extension end)

Accessory on the body

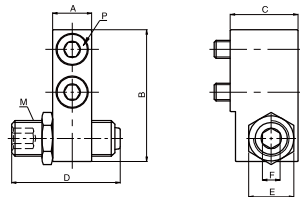

Accessory on the slide

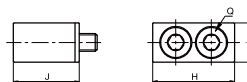

Bore/Sign	Adjustable stroke range	A	B	C	D	E	F	M	P	H	I	J	Q
6	10	7	19	10.5	22.5	8	3	M6X1.0	M2.5 Length 10	12.5	6.5	10.5	M2.5 Length 10
8	10	7	22	15.5	27.5	11	4	M8X1.0	M3 Length 16	16.6	7	15.5	M3 Length 16
12	10	9.5	29	16	27.5	11	4	M8X1.0	M4 Length 14	20.5	9	15	M4 Length 14
16	10	11	36	19	30.5	12.7	5	M10X1.0	M5 Length 18	23	11	18.5	M5 Length 18
20	10	13	45	26	34	19	6	M14X1.5	M6 Length 25	27	12	25.5	M6 Length 25
25	10	16	54	24	34	19	6	M14X1.5	M8 Length 20	33	17	23	M8 Length 20

### BS (With shock absorber at extension end)

Accessory on the body

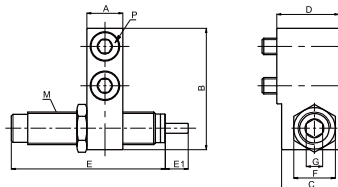

Accessory on the slide

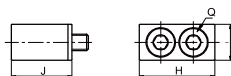

Bore/Sign	A	B	C	D	E	E1	F	M	P	H	I	J	Q
8	7	22	14	15.5	38	6	11	M8X1.0	M3 Length 16	16.6	7	15.5	M3 Length 16
12	9.5	29	14.5	16	38	6	11	M8X1.0	M4 Length 14	20.5	9	15	M4 Length 14
16	11	36	17.5	19	43	7	12.7	M10X1.0	M5 Length 18	23	11	18.5	M5 Length 18
20	13	45	23.5	26	76	12	19	M14X1.5	M6 Length 25	27	12	25.5	M6 Length 25
25	16	54	22	24	76	12	19	M14X1.5	M8 Length 20	33	17	23	M8 Length 20

## Main Dimensions

### AF (With stroke adjusting screws at retraction end)

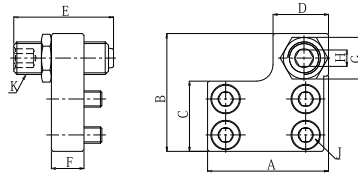

Bore/Sign	Adjustable stroke range	A	B	C	D	E	F	G	H	J	K
6	10	18	19	11.2	8	22.5	6	8	3	M2.5 Length 6	M6X1.0
8	10	24.5	22.2	13.2	13	27.5	8	11	4	M3 Length 8	M8X1.0
12	10	31.5	29	18	15	27.5	8	11	4	M4 Length 8	M8X1.0
16	10	37	36	21.5	17	30.5	10	12.7	5	M5 Length 10	M10X1.0
20	10	45	44	26	23	34	12	19	6	M5 Length 12	M14X1.5
25	10	51	53.5	34	25	34	15	19	6	M6 Length 16	M14X1.5

### BF (With shock absorber at retraction end)

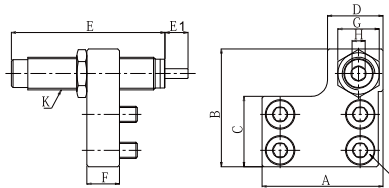

Bore/Sign	A	B	C	D	E	E1	F	G	J	K
8	24.5	22.2	13.2	13	38	6	8	11	M3 Length 8	M8X1.0
12	31.5	29	18	15	38	6	8	11	M4 Length 8	M8X1.0
16	37	36	21.5	17	43	7	10	12.7	M5 Length 10	M10X1.0
20	45	44	26	23	76	12	12	19	M5 Length 12	M14X1.5
25	51	53.5	34	25	76	12	15	19	M6 Length 16	M14X1.5

# EXSW Series Slide Cylinder



## EXSW Slide Cylinder

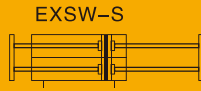

### Specifications

Bore(mm)	16	20	25	32
Acting type	Double acting			
Working Medium	Clean Air(after 40 μ m filtration)			
Working Pressure (MPa)	0.1~1.0			
Guaranteed Pressure (MPa)	1.5			
Working Temperature (°C)	-20~80( No freezing)			
Speed range (mm/s)	30~500			
Cushion type	Rubber cushion			
Stroke tolerance(mm)	+1.0 0			
Adjustable stroke(mm)	-5~0			
No-rotating precision	± 0.05°		± 0.03°	
Port Size	M5 x 0.8		G1/8	

① PT、NPT port size is optional.

### How to Order?

Series No	Type No	Bore X	Stroke	Magnet No	Thread Type
EXSW	M: Slide bearing	16 20 25 32	25 50 75 ...	S : With magnet	Blank: G P : PT T : NPT

#### Order Example:

EXSW series, Slide Bearing type, Bore 16mm, stroke 30mm ERP code is: EXSWM16X30-S

### Optional Accessories

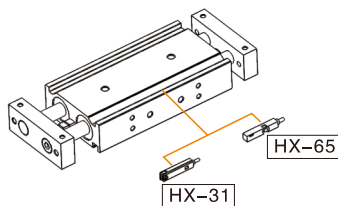

### Stroke

Bore (mm)	Standard Stroke (mm)	Max. Stroke (mm)
16-32	10 20 30 40 50 75 100 125 150	150

Note: Above chart shows standard stroke, for unstandard stroke, please contact with us.

### Internal Structure

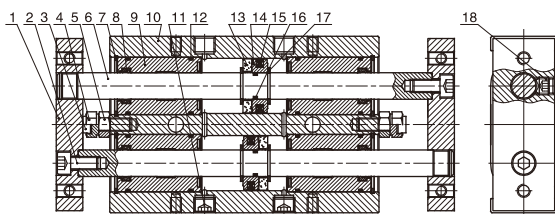

No.	Part Name	Material
1	Fixing plate	Aluminum alloy
2	Nut	Carbon steel
3	Bumper	POM
4	Adjustable nut	Carbon steel
5	Screw	Carbon steel
6	Piston rod	S45C hard chrome carbon steel
7	C clip	Spring steel
8	Wiper seal	NBR
9	Head cover	Aluminum alloy
10	Body	Aluminum alloy
11	Hex fix screw	Cu
12	O-ring	NBR
13	Magnet	Plastic
14	Piston	Aluminum alloy
15	Piston seal	NBR
16	O-ring	NBR
17	C clip	Spring steel
18	Nut	Carbon steel

## Main Dimension

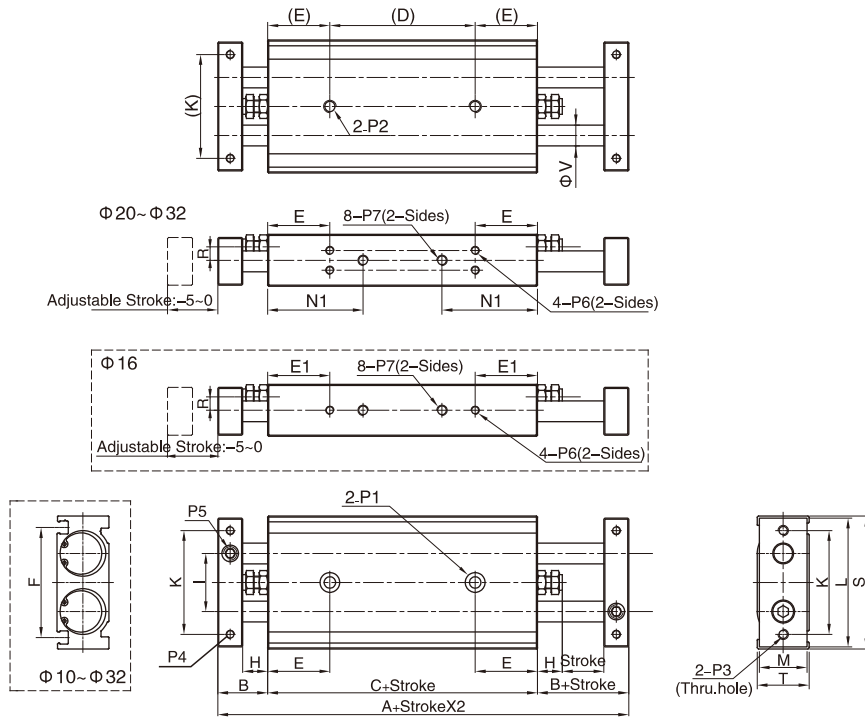

																	(mm)
Bore\Sign	A	B	C	E	E1	F	H	I	K	L	M	N1	R	S	T	V	W
16	133	19	95	25	25	47,5	9	25	45	56	18	38	5	58	20	8	-
20	158	24	110	30	30	53	12	28	50	62	23	46	6,5	64	25	10	9,5
25	160	24	112	30	30	64	12	35	60	78	28	43	9	80	30	12	13
32	193	30	133	30	30	76	14	44	75	96	36	53	11,5	98	38	16	20
Bore\Sign	P1			P2			P3		P4		P5		P6		P7		
16	Φ8 Dp:4.4; Thru.hole: Φ4.3			M5X0.8 Dp:8			M5X0.8		M4X0.7		M6X1.0		M4X0.7 Dp:5		M5X0.8		
20	Φ9.5 Dp:5.3; Thru.hole: Φ5.2			M6X1.0 Dp:10			M5X0.8		M4X0.7 Dp:6		M8X1.25		M4X0.7 Dp:5.5		M5X0.8		
25	Φ11 Dp:6.3; Thru.hole: Φ6.8			M8X1.25 Dp:12			M6X1.0		M5X0.8 Dp:7.5		M8X1.25		M5X0.8 Dp:7		1/8"		
32	Φ11 Dp:6.3; Thru.hole: Φ6.8			M8X1.25 Dp:12			M6X1.0		M5X0.8 Dp:8		M10X1.5		M5X0.8 Dp:7		1/8"		

# ESW Series Rodless Cylinder



## ESW

### Rodless Cylinder



#### Specifications

Bore(mm)	16	20	25	32
Acting Type	Double Acting			
Working Medium	Clean Air(40 μ m filtration )			
Pressure Range	0.15~0.7			
Guaranteed Pressure ( Mpa)	1.0			
Working Temperature(℃ )	-20~80 ( No freezing)			
Piston Speed(mm/s)	50~400			
Stroke tolerance	0~250 <sup>+1.0</sup> <sub>0</sub>	251~1000 <sup>+1.4</sup> <sub>0</sub>	1001~ <sup>+1.8</sup> <sub>0</sub>	
Cushion Type	Rubber cushion on both ends			
Port Size	M5x0.8	G1/8 ①		

① PT、NPT port size is optional.

Note: Max working pressure of cylinder should not exceed 0.7Mpa, otherwise the magnetic coupling is in risk of disengagement

#### How to Order?

Series	Type	Bore	X Stroke	Mounting Type	Thread Type
ESW	Blank:Basic type	16 20 25 32	100 150 200 250 ... 800	Blank:No LB FA	Blank:G P:PT T:NPT

#### Order Example

ESW series, basic type, bore 32mm, stroke 50mm, G thread, ERP code is ESW32 x 50

#### Optional Accessories

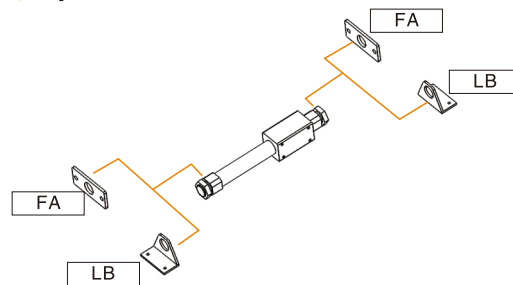

#### Stroke

Bore (mm)	Standard Stroke (mm)	Max. Stroke (mm)
16	50 100 150 200 250 300 350 400 450 500	1000
20	50 100 150 200 250 300 350 400 450 500 600 700 800	2000
25	50 100 150 200 250 300 350 400 450 500 600 700 800	2000
32	50 100 150 200 250 300 350 400 450 500 600 700 800	2000

Notes: With the increase of stroke, cylinder barrel increase bending degree, pls note the gap size between connecting part and cylinder.

#### Magnetic Retention

Bore(mm)	Magnetic Retention(N)
16	140
20	200
25	360
32	550

#### Internal Structure

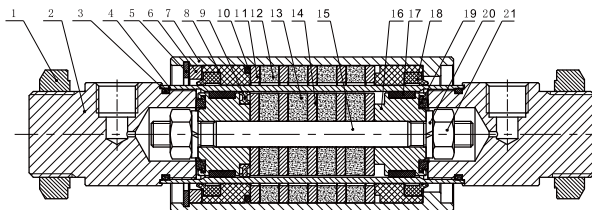

No.	Part Name	Material	No.	Part Name	Material
1	Hex Nut	Carbon Steel	12	Magnet	Sintered NdFeB
2	Cover	Aluminum Alloy	13	Magnet	Sintered NdFeB
3	O Ring	NBR	14	Blocking Plate for Barrel	Carbon Steel
4	Barrel	Stainless Steel	15	Connecting Rod	Stainless Steel
5	Retaining ring	Spring Steel	16	Piston	Aluminum Alloy
6	Slider baffle	Aluminum Alloy	17	Wear Ring	PTFE
7	Slider	Aluminum Alloy	18	Soft Dust Removing Seal	Special Material
8	Wear Ring	PTFE	19	Bumper	TPU
9	Piston Seal	NBR	20	Spring Bumper	Carbon Steel
10	O Ring	NBR	21	Hex Nut	Carbon Steel
11	Blocking Plate for Slider	Carbon Steel			

## Main Dimension

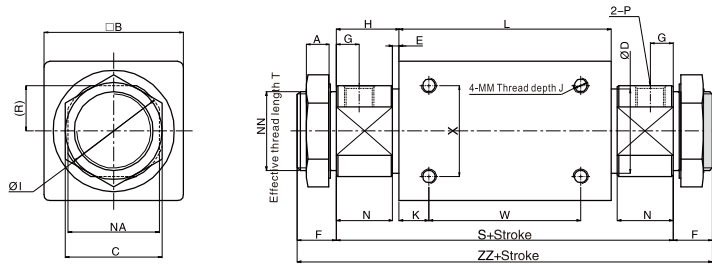

Model/Sign	A	B	C	D	E	F	G	H	I	J	K	L	MM	N	NA	NN	R	S	T	W	X	ZZ	P
ESW16	4	35	14	18	2	10	5.5	13	22	5	11	57	M4X0.7	11	20	M10X1.0	10	83	8	35	19	103	M5X0.8
ESW20	7	36	26	22.8	2	13	7.5	20	28	6	8	66	M4X0.7	18	24	M20X1.5	12	106	10.5	50	25	132	1/8"
ESW25	8	46	32	27.8	2	13	7.5	20.5	33.5	7.5	10	70	M5X0.8	18.5	30	M26X1.5	15	111	10.5	50	30	137	1/8"
ESW32	8	60	32	35	2	16	8	22	40	8	15	80	M6X1.0	20	36	M26X1.5	18	124	13.5	50	40	156	1/8"

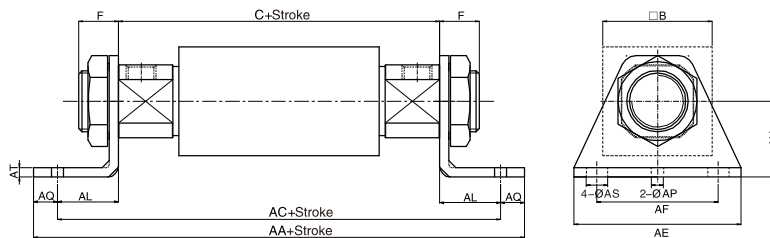

Model/Sign	AA	AC	C	F	AE	AF	AH	AL	AP	AS	AQ	AT	B	LB Ordering Code
16	111	101	83	10	42	33	20	9	-	5.4	5	2.5	35	FJ-ESW16LB
20	162	146	106	13	55	40	25	20	4	7	8	3	36	FJ-SM20LB
25	167	151	111	13	55	40	28	20	4	7	8	3	46	FJ-SM25LB
32	180	164	124	16	55	40	28	20	4	7	8	3	60	FJ-SM25LB

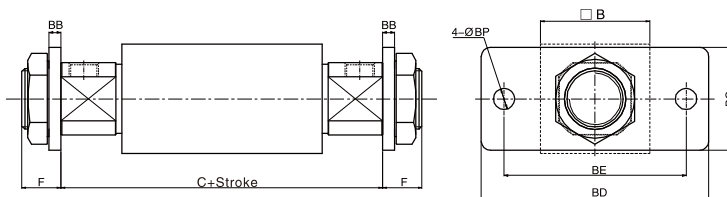

Model/Sign	B	BB	BC	BD	BE	BP	C	F	FA Ordering Code
20	36	4	34	75	60	7	106	13	FJ-SM20FA
25	46	4	40	75	60	7	111	13	FJ-SM25FA
32	60	4	40	75	60	7	124	16	FJ-SM25FA

## Installation and Operation

1. Load capacity of the ESW rodless cylinder series is determined by the theoretical holding force (theoretical thrust). The weight of the load cannot exceed the theoretical holding force, as stated at below chart.

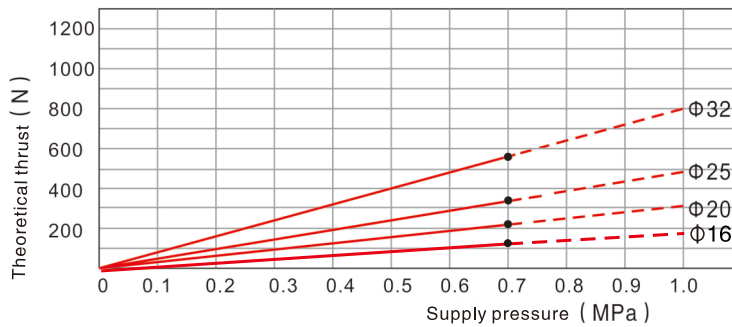

## 2. The downward bending deflection of the cylinder self-weight

Horizontal installation: the downward bending deflection of self-weight is shown in the figure below. As the stroke becomes longer, variations in the center axis become larger. Consider using a connection method that is able to absorb these bending deflection.

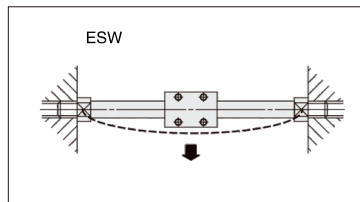
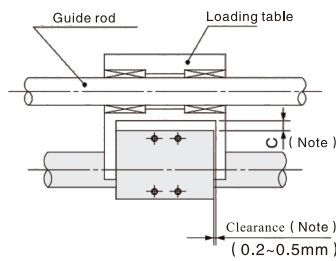

Note: Please reserve clearance according to the self-weight downward bending range shown in the right figure to prevent the cylinder from touching the installation surface or the load, so that the cylinder can slide smoothly within the minimum pressure range.

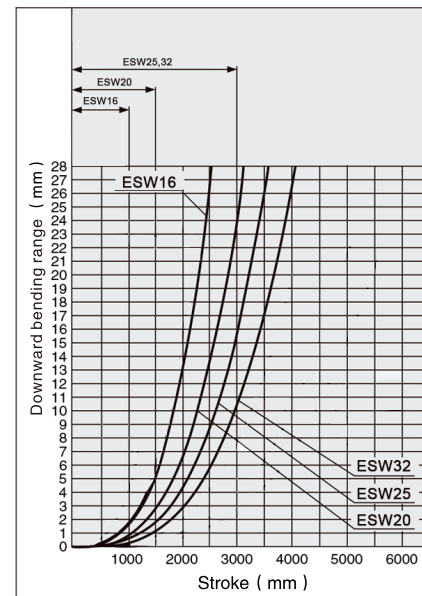

Note: the data of downward bending range is measured when the external slider moves to the middle of the stroke.

## 3. Maximum load including the adapting piece

Load cannot be installed on the ESW series cylinders directly, please use other axis (linear guide rail, etc.) as oriented device. Maximum load including the adapting piece must be lower than the figures in the chart below.

Model	Maximum Load(KG)
ESW16	1.0
ESW20	1.1
ESW25	1.2
ESW32	1.5

## Installation and Operation

### 4. Vertical movements

- 4.1 Please use rolling bearing (linear guide rail, etc.) as oriented device.  
If the sliding bearing was used, the sliding resistance will increase due to the load and the torque generated by the load, resulting in poor movement.

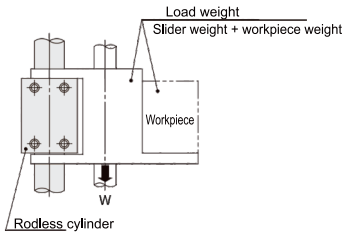

Model	Allowable load weight(KG)	Maximum working pressure(MPa)
ESW16	7.0	0.65
ESW20	11.0	0.65
ESW25	18.5	0.65
ESW32	30.0	0.65

Note: If the actual pressure exceeds the maximum working pressure, the magnetic coupling is at risk of demagnetizing, attention please.

### 5. In case of stopping the slider halfway, please refer to the specific parameters in below chart

- 5.(1) If using an external stopper is used to stop the cylinder, working pressure cannot exceed the specified values listed in the chart below. Once the applied pressure exceeds the threshold limited, the magnetic coupling is at risk of demagnetizing, attention please..

Model	Maximum threshold value while stop halfway (MPa)
ESW16	0.65
ESW20	0.65
ESW25	0.65
ESW32	0.65

- 5.(2) If using a pneumatic circuit to stop the cylinder, the kinetic energy cannot exceed the specified values listed in the chart below. Once the applied pressure exceeds the threshold limited, the magnetic coupling is at risk of demagnetizing, attention please.

Model	Allowable kinetic energy while stop halfway(Es)(J)
ESW16	0.13
ESW20	0.24
ESW25	0.45
ESW32	0.88

5. (3) If the load is stopped at the end of stroke, cylinder may be tilted due to the big inertia and both the bearing and cylinder barrel will be damaged. (as shown in the left picture below).  
By using a stopper and a shock absorber together, the thrust will be passed through the cylinder body to avoid cylinder tilting. (as shown in the right picture below).

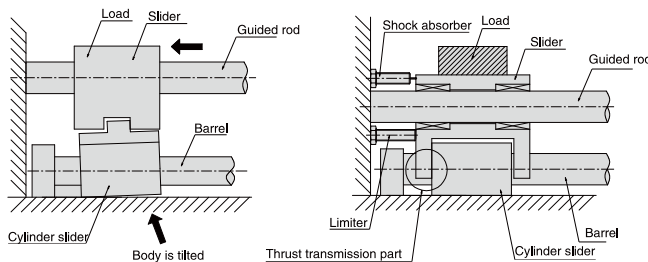

5. (4) In a vertical installation situation, a pneumatic circuit cannot be used to stop the cylinder. Piston stopped because of pressure increase, but the magnetic coupling is at risk of demagnetizing due to the weight and inertia of the load.

# ESWT Series Guide Rod Type Rodless Cylinder



## ESWT

### Guide Rod Type Rodless Cylinder

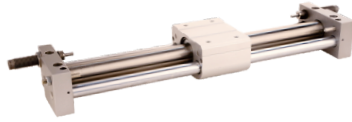
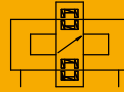

### Specifications

Bore(mm)	16	20	25	32
Acting Type	Double Acting			
Working Medium	Clean Air(40 μm filtration )			
Pressure Range	0.18~0.7			
Guaranteed Pressure ( Mpa)	1.05			
Working Temperature(°C )	-20~80 ( No freezing)			
Piston Speed(mm/s)	50~400			
Stroke Tolerance	0~250 <sup>+1.0</sup> <sub>0</sub>	251~1000 <sup>+1.4</sup> <sub>0</sub>	1001~ <sup>+1.8</sup> <sub>0</sub>	
Cushion Type	Rubber cushion/Shock absorber			
Magnetic Retention	140	200	360	550
Port Size	M5x0.8		G1/8 ①	

① PT、NPT port size is optional.

### How to Order?

Series	Type	Bore X Stroke	Magnet.No	Cushion Type	Thread Type	
ESWT(Slide bearing)	Blank: Both sides tubing	16	50	Blank: No magnet	Blank: Both sides adjustable screw cushion B: Both sides oil buffer with adjustable nut BS: Plate A oil buffer and adjusted nut Plate B or C adjusted screw	Blank:G P:PT T:NPT
	G: Central tubing	20	100	S: With magnet		
		25	150			
		32	200			
			250			
		.....				

Blank	Both sides adjustable screw cushion	
B	Both sides oil buffer with adjustable nut	
BS	Plate A oil buffer and adjusted nut Plate B or C adjusted screw	

Note: When in central tubing occasion, the port is in plate A side.

#### Order Example

ESWT Series Guide Rod Type Rodless Cylinder, Bore 32,Stroke 50,No magnet,: Both sides adjustable screw cushion,G thread, the ERP code is:ESWTG32X50-B

### Optional Accessories

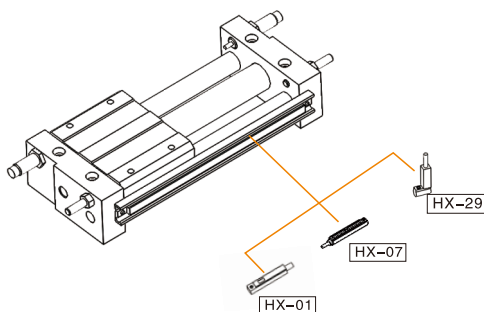

### Stroke

Bore (mm)	Standard Stroke (mm)											Max. Stroke (mm)		
16	50	100	150	200	250	300	350	400	450	500		750		
20	50	100	150	200	250	300	350	400	450	500	600	700	800	1000
25	50	100	150	200	250	300	350	400	450	500	600	700	800	1500
32	50	100	150	200	250	300	350	400	450	500	600	700	800	1500

## Internal Structure

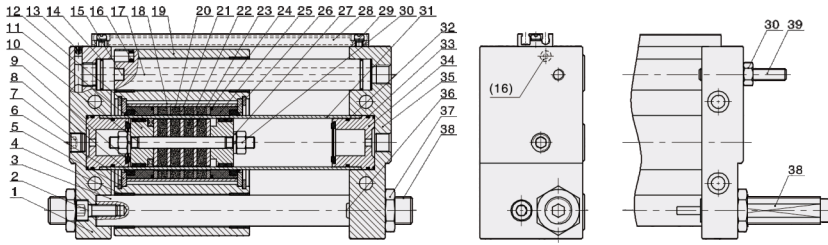

No.	Part Name	Material	No.	Part Name	Material
1	Plate B	Aluminum alloy	21	Sliding block partition	Fast cutting steel
2	Hex fix screw	Carbon steel	22	Magnet	Sintered NdFeB
3	Guide rod A	Carbon steel	23	Barrel plate	Fast cutting steel
4	Bearing	Copper	24	O-ring	NBR
5	C type retainer ring	Spring steel	25	Wear ring	PTFE
6	Ontology baffle	Aluminum alloy	26	Wear ring	PTFE
7	Hex fix plug	Carbon steel	27	Spring washer	Carbon steel
8	Blowing dust ring	TPU	28	Switch base	Aluminum alloy
9	Anti-bump cushion	TPU	29	Screw	Carbon steel
10	Connecting rod	Stainless steel	30	Hexagonal nut	Carbon steel
11	Piston	Aluminum alloy	31	Barrel	Stainless steel
12	Piston rod seal	NBR	32	O-ring	NBR
13	Steel ball	Stainless steel	33	O-ring	NBR
14	O-ring	NBR	34	Anti-bump base	Aluminum alloy
15	Soft dust scraping ring	Stainless steel	35	Plate A	Aluminum alloy
16	Magnet	Sintered NdFeB	36	Anti-bump cushion	TPU
17	Guide rod C	Carbon steel	37	Hexagonal nut	Carbon steel
18	Sleeve	Aluminum alloy	38	Adjustable screw	Carbon steel
19	Body	Aluminum alloy		Oil shock absorber	Components
20	Magnet	Sintered NdFeB	39	Adjustable nut	Carbon steel

## About Shock Absorber

- Shock absorbers are consumable parts .When a decrease in energy absorption capacity is noticed ,it must be replaced. Refer to the table below for the absorber type.  
Please order corresponding shock absorber according to the table and replace the old ones according to the procedure .
- Never loosen the bottom screw of the shock absorber.  
(It is not an adjustment screw.) That may cause oil leakage.
- Refer to the table below for tightening torques of the shock absorber setting nut.

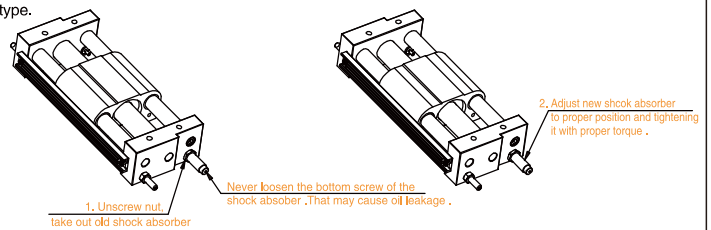

Model	ESWT16	ESWT20	ESWT25	ESWT32
Shock absorber type	AC0806-WY	AC1007-WY	AC1412-WY	AC2015-WY
Tightening torque(Nm)	1.67	3.14	10.8	10.8

## About Sensor Switch

- Sensor switch only can be used for the cylinder with magnet.  
The magnet located the four corner of body' s (refer below).  
The cylinder with magnet have both group mounting hole for mounting rail.  
Please refer to below to order sensor switch ,mounting it into the rail' s groove, adjusting it to proper position ,tightening it with proper torque.

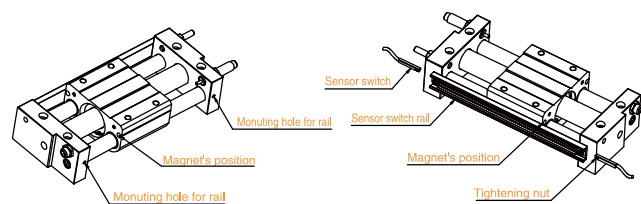

Model	ESWT16-S	ESWT20-S	ESWT25-S	ESWT32-S
Sensor switch type	HX-01、HX-07			

Please refer to the detailed information of sensor switch on page [3.119~3.120](#)

# ESWT Series Guide Rod Type Rodless Cylinder



## Main Dimension

### ESWTG(Central tubing)

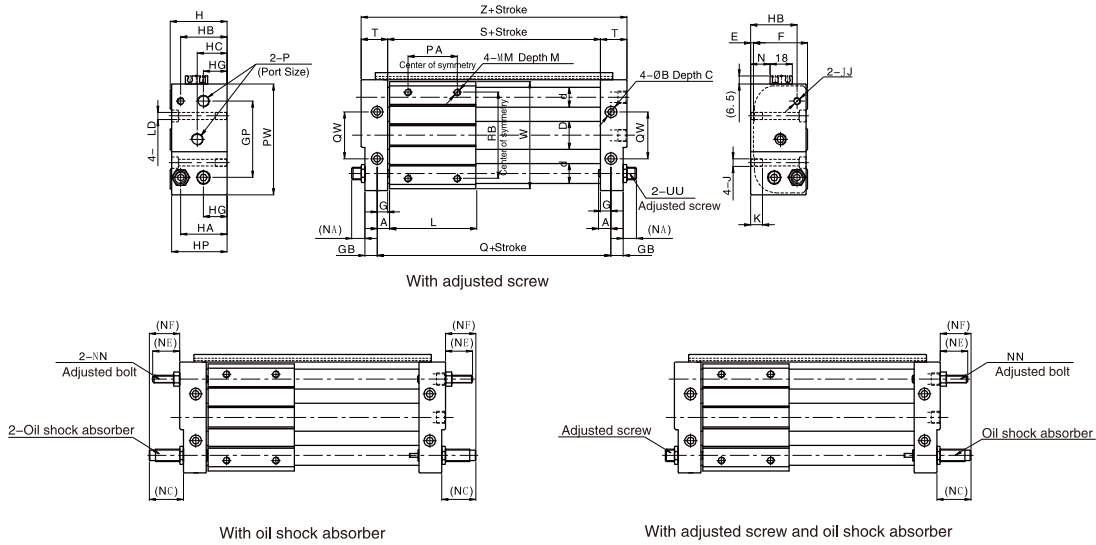

### ESWT(Both sides tubing)

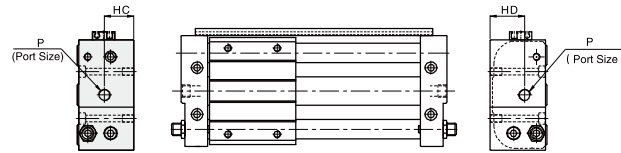

Note: Other dimensions of both sides tubing and central tubing are same.

### Stroke adjustment

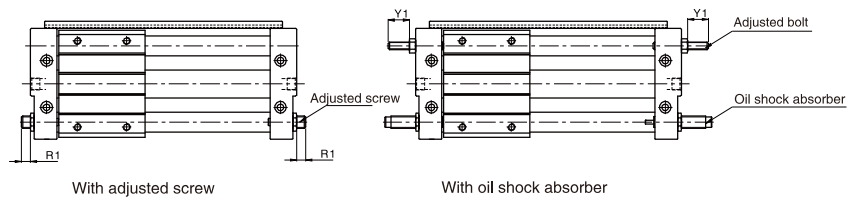

Note: Both sides tubing and central tubing have the same stroke adjustment.

Bore/Sign	A	B	C	D	d	E	F	G	GB	GP	H	HA	HB	HC	HD	HG	HP
16	7.5	9.5	5.5	18	12	2	38	6.5	8.5	52	40	29.5	29.5	20.5	20	15	39
20	10	9.5	5.5	22.8	16	2	44	8.5	10	62	46	37.5	37.5	24	28	19	45
25	10	11	6.5	27.8	16	2	52	8.5	10	70	54	40.5	40.5	27.5	31.5	21.5	53
32	12.5	14	8.5	35	20	2	64	9.5	11	86	66	50	50	33	37	26	64
Bore/Sign	J	K	JJ	L	LD	M	MM	N	NA	NC	NE	NF	NN	P	PA	PB	
16	M6X1.0	9.5	M6X1.0	60	5.5	8	M5X0.8	10.5	11.5	23	26.5	22.8	M6X1.0	M5X0.8	30	50	
20	M6X1.0	9.5	M6X1.0	70	5.5	10	M6X1.0	15.6	10.5	23.7	22	24.7	M6X1.0	1/8"	40	70	
25	M8X1.25	10	M6X1.0	70	7	10	M6X1.0	19.6	14	56.7	22	44.7	M6X1.0	1/8"	40	70	
32	M10X1.5	15	M6X1.0	85	8.5	12	M8X1.25	25.6	14	90.5	17.5	46.5	M6X1.0	1/8"	40	75	
Bore/Sign	PW	Q	QW	R1	Adjust the bolt adjustment (Two sides R1X2)		S	T	UU	W	Y1	Adjust the bolt adjustment (Two sides Y1X2)		Z			
16	76	75	30	8.5	17		62	17.5	M8X1.0	73	21.5	43		97			
20	90	90	38	7.5	15		73	21.5	M10X1.0	87	17	34		116			
25	99	90	42	9	18		73	21.5	M14X1.5	96	17	34		116			
32	119	110	50	7	14		91	24.5	M20X1.5	116	12.5	25		140			

## FVBC

### Standard Cylinder



#### Specifications

Bore Size (mm)	32	40	50	63	80	100
Acting type	Double Acting					
Working medium	Clean Air(40 μm filtration)					
Working pressure (MPa)	0.1~1.0					
Guaranteed pressure (MPa)	1.5					
Working temperature (°C)	-20~80(No freezing)					
Speed range (mm/s)	50~800					
Cushion type	Air Cushion					
Cushion stroke (mm)	27	30		36		
Mounting type	LB FA FB CA CB CR					
Port size ①	G1/8	G1/4		G3/8		G1/2

① PT, NPT port size is optional.

#### How to Order?

Series No.	Cushion Type	Type No.	Bore X Stroke	Adjustable Stroke	Magnet No.	Seal Material	Mounting Type	Thread Type
FVB: Square type barrel	C: Air cushion	32 40 50 63 80 100	25 50 75 ...	10 20 30 40 50 75 100	Blank: No magnet S: With magnet	Blank: TPU seal	Blank: No CA CB IJ CR YJ LB YCJ FA BJ FB FD	Blank: G P: PT T: NPT
	Blank: Basic type D: Double shaft type J: Double shaft and adjustable stroke type							

#### Order Example:

FVBC series, double shaft air cylinder, Bore 40mm, stroke 50mm, with magnet, TPU seal material, CA mounting accessory, NPT thread.

ERP code is: FVBCD 40X50-S-CA-T

Note: If cylinder with several different mounting accessories, please use this sequential coding: CA/CB/CR/LB/FA/FB/IJ/YJ/BJ/FD

#### Optional Accessories

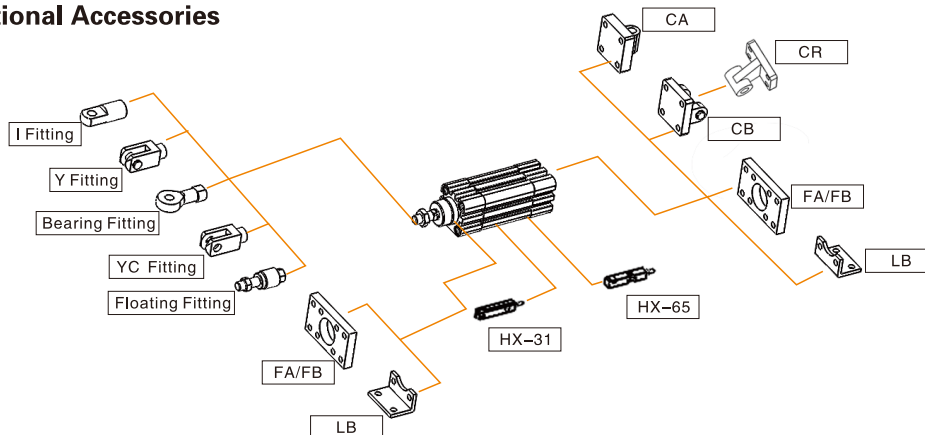

#### Stroke

Bore (mm)	Standard Stroke (mm)	Max. Stroke (mm)
32	25 50 75 80 100 125 150 160 175 200 250 300 350 400 450 500	1900
40	25 50 75 80 100 125 150 160 175 200 250 300 350 400 450 500 600 700 800	1900
50-100	25 50 75 80 100 125 150 160 175 200 250 300 350 400 450 500 600 700 800 900 1000	1900

# FVBC Series ISO15552 Standard Cylinder



## Internal Structure

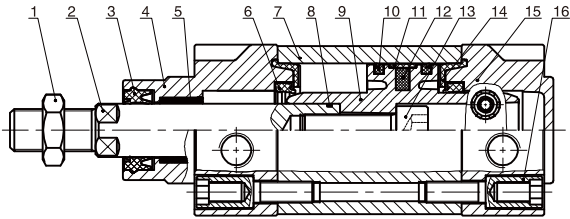

NO.	Part Name	Material
1	Nut	Carbon steel
2	Piston rod	S45C hard chrome carbon steel
3	Piston rod seal	TPU
4	Head cover	Aluminum alloy
5	Self lubricating bearing	Bronze powder
6	Cushion seal	TPU
7	Barrel	Aluminum alloy
8	O-ring	NBR
9	Piston	Aluminum alloy
10	Piston seal	TPU
11	Wear ring	PTFE
12	Magnet	Plastic
13	Hexagon screw	Carbon steel
14	Cushion pad	TPU
15	Rear cover	Aluminum alloy
16	Bolt	Carbon steel

## Main Dimension

FVBC

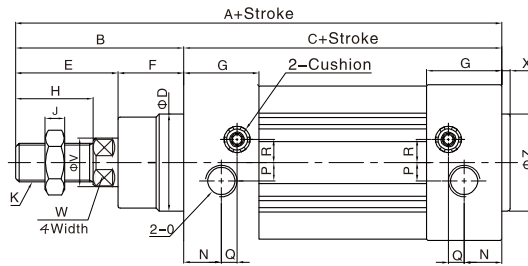
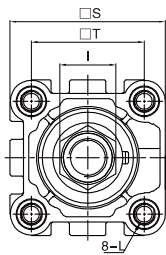

(mm)

Bore/Sign	A	B	C	D	E	F	G	H	I	J	K	L	N	O	P	Q	R	S	T	V	W	X	Z
32	142	48	94	30	29	19	27.5	22	17	6	M10x1.25	M6 Dp.16	13	1/8"	5.5	6	6	46.5	32.5	12	10	3	30
40	159	54	105	35	33	21	32	24	17	7	M12x1.25	M6 Dp.16	17	1/4"	6	7.5	8.5	54	38	16	13	3.5	35
50	175	69	106	40	42	27	31	32	23	8	M16x1.5	M8 Dp.16	15.5	1/4"	7.5	6.5	9.5	64	46.5	20	17	3.5	40
63	190	69	121	45	42	27	33	32	23	8	M16x1.5	M8 Dp.16	16.5	3/8"	7.5	7.5	11.5	75	56.5	20	17	4	45
80	214	86	128	45	53	33	33	40	26	10	M20x1.5	M10 Dp.17	16.5	3/8"	8	8.5	12.5	93	72	25	22	4	45
100	229	91	138	55	55	36	37	40	26	10	M20x1.5	M10 Dp.17	19.5	1/2"	10	7	12	110	89	25	22	4	55

Note: With magnet and without magnet, the dimensions are same.

FVBCD

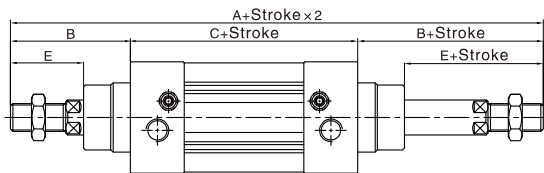

Bore/Sign	A	A1	B	C	E	Z	J	K
32	190	188	48	94	29	27	6	M10x1.25
40	213	208	54	105	33	28	7	M12x1.25
50	244	233	69	106	42	31	8	M16x1.5
63	259	248	69	121	42	31	8	M16x1.5
80	300	286	86	128	53	39	10	M20x1.5
100	320	304	91	138	55	39	10	M20x1.5

FVBCJ

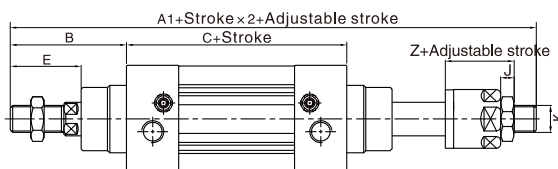

Note: 1. With magnet and no magnet, the dimensions are same.  
2. Not marked dimension is same as FVBC standard type.  
3. FVBC series dimensions is same as FVBC.

## Dimension of Mounting Accessories

⊙LB



Bore/Sign	AA	AC	AD	AE	AF	AG	AH	AP	AT
FJ-VBC32LB	158	142	8	47	32	24	32	7	4
FJ-VBC40LB	179	161	9	53	36	28	36	9	4
FJ-VBC50LB	190	170	10	65	45	32	45	9	5
FJ-VBC63LB	209	185	12	75	50	32	50	9	5
FJ-VBC80LB	248	210	19	95	63	41	63	12.5	6
FJ-VBC100LB	258	220	19	115	75	41	71	14.5	6

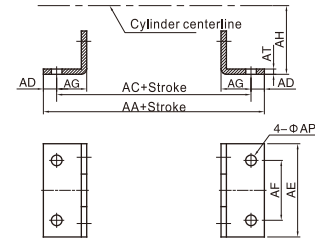

⊙FA/FB



Bore/Sign	AJ	AK	BA	BB	BC	BD	BE	BF	BH	BP	T
FJ-VBC32FA	11	7	30.5	10	47	32	80	64	6	7	32.5
FJ-VBC40FA	11	7	35.5	10	53	36	90	72	6	9	38
FJ-VBC50FA	14	9	40.5	12	65	45	110	90	8	9	46.5
FJ-VBC63FA	14	9	45.5	12	75	50	125	100	8	9	56.5
FJ-VBC80FA	17	11	45.5	16	95	63	154	126	10	12.5	72
FJ-VBC100FA	17	11	55.5	16	115	75	186	150	10	14.5	89

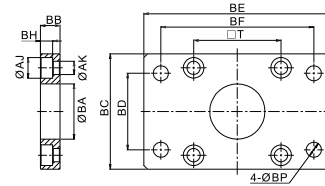

⊙CA



Bore/Sign	DA	DC	DE	DJ	DP	DQ	DZ	S	T
FJ-VBC32CA	31	22	10	9.5	7	25.8	5.5	47	32.5
FJ-VBC40CA	37	25	12	9.5	7	27.8	5.5	53	38
FJ-VBC50CA	39	27	12	10.5	9	31.8	6.5	65	46.5
FJ-VBC63CA	47	32	16	10.5	9	39.7	6.5	75	56.5
FJ-VBC80CA	51	36	16	14.5	11	49.7	10	95	72
FJ-VBC100CA	61	41	20	14.5	11	59.7	10	115	89

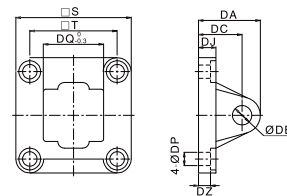

⊙CB



Bore/Sign	DA	DC	DE	DJ	DP	DQ	DT	DZ	S	T
FJ-VBC32CB	31	22	10	9.5	7	26 <sup>+0.52</sup> <sub>0</sub>	45	5.5	47	32.5
FJ-VBC40CB	37	25	12	9.5	7	28 <sup>+0.52</sup> <sub>0</sub>	52	5.5	53	38
FJ-VBC50CB	39	27	12	10.5	9	32 <sup>+0.62</sup> <sub>0</sub>	60	6.5	65	46.5
FJ-VBC63CB	47	32	16	10.5	9	40 <sup>+0.62</sup> <sub>0</sub>	70	6.5	75	56.5
FJ-VBC80CB	51	36	16	14.5	11	50 <sup>+0.62</sup> <sub>0</sub>	90	10	95	72
FJ-VBC100CB	61	41	20	14.5	11	60 <sup>+0.74</sup> <sub>0</sub>	110	10	115	89

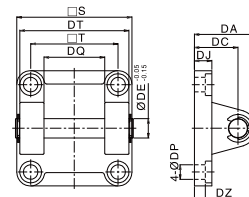

⊙CR



Bore/Sign	DC	DD	DE	DF	DJ	DQ	DM	DN	S	T
FJ-VBC32CR	32	10	10	21	8	25.8	31	18	51	38
FJ-VBC40CR	36	11	12	24	10	27.8	35	22	54	41
FJ-VBC50CR	45	13	12	33	12	31.8	45	30	65	50
FJ-VBC63CR	50	15	16	37	12	39.7	50	35	67	52
FJ-VBC80CR	63	15	16	47	14	49.7	60	40	86	66
FJ-VBC100CR	71	19	20	55	15	59.7	70	50	96	76

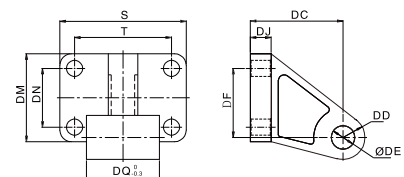

# VBC/LBC Series ISO15552 Standard Cylinder



## VBC/LBC Standard Cylinder



### Specifications

Bore Size (mm)	32	40	50	63	80	100	125	160	200	250
Acting type	Double Acting									
Working medium	Clean Air(40 μm filtration)									
Working pressure (MPa)	0.1~1.0									
Guaranteed pressure (MPa)	1.5									
Working temperature (°C)	-20~80(No freezing)									
Speed range (mm/s)	50~800									
Cushion type	Air Cushion									
Cushion stroke (mm)	27	30	36	34	35	42	50			
Mounting type	LB FA FB CA CB CR									
Port size ①	G1/8	G1/4	G3/8	G1/2	G3/4	G1				

① PT, NPT port size is optional.

### How to Order?

Series No	Cushion Type	Type No.	Bore X	Stroke - Adjustable Stroke	Magnet No.	Seal Material	Mounting Type	Thread Type
VB: Profile barrel LB: Round barrel	C: Air cushion Blank: Basic type D: Double shaft type J: Double shaft and adjustable stroke type	32 40 50 63 80 ... 250	25 50 75 ... 100	10 20 30 40 50 75 100	Blank: No magnet S: With magnet	Black: TPU seal	Blank: No CA CB J CR YJ LB YCJ FA BJ FB FD	Blank: G P: PT T: NPT

#### Order Example:

VBC series, double shaft air cylinder, Bore 40mm, stroke 50mm, with magnet, TPU seal material, CA mounting accessory, NPT thread.  
ERP code is: VBCD 40X50-S-CA-T

Note:1. If cylinder with several different mounting accessories, please use this sequential coding: CA/CB/CR/LB/FA/FB/IJ/YJ/BJ/FD

- VBC series, bore range: Φ32~Φ200;LBC series,bore range: Φ32~Φ250
- No CR/LB option for Φ200

### Optional Accessories

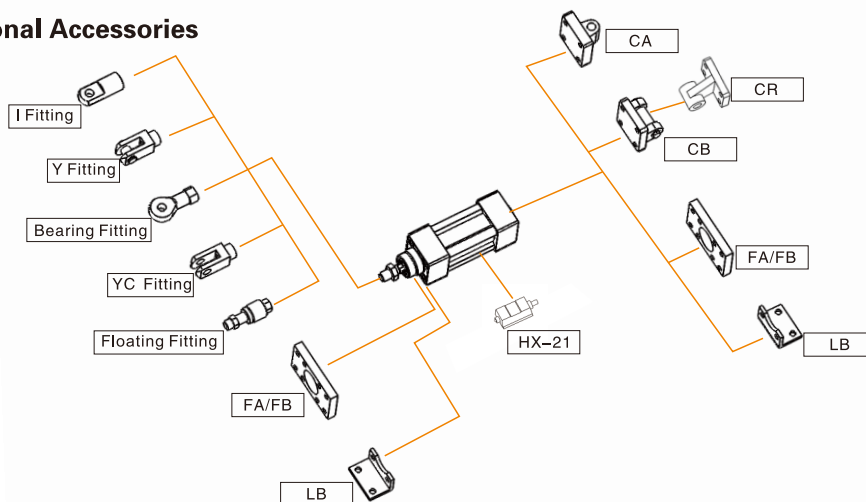

### Stroke

Bore (mm)	Standard Stroke (mm)	Max. Stroke (mm)
32	25 50 75 80 100 125 150 160 175 200 250 300 350 400 450 500	1900
40	25 50 75 80 100 125 150 160 175 200 250 300 350 400 450 500 600 700 800	1900
50~250	25 50 75 80 100 125 150 160 175 200 250 300 350 400 450 500 600 700 800 900 1000	1900

## Internal Structure

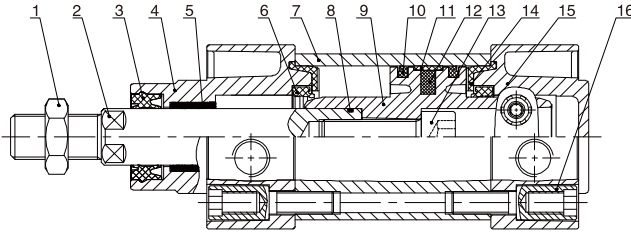

NO.	Part Name	Material
1	Nut	Carbon steel
2	Piston rod	S45C hard chrome carbon steel
3	Piston rod seal	TPU
4	Head cover	Aluminum alloy
5	Self lubricating bearing	Bronze powder
6	Cushion seal	TPU
7	Barrel	Aluminum alloy
8	O-ring	NBR
9	Piston	Aluminum alloy
10	Piston seal	TPU
11	Wear ring	PTFE
12	Magnet	Plastic
13	Hexagon screw	Carbon steel
14	Cushion pad	TPU
15	Rear cover	Aluminum alloy
16	Bolt	Carbon steel

## Main Dimension

VBC

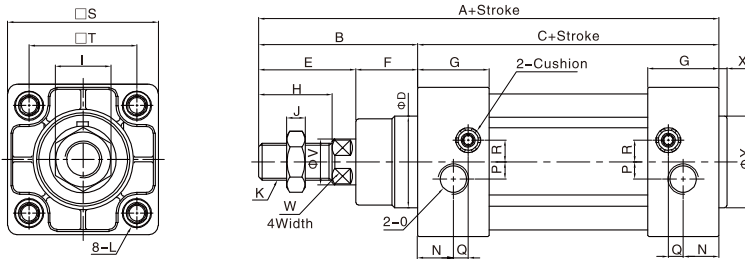

Bore/Sign	A	B	C	D	E	F	G	H	I	J	K	L	N	O	P	Q	R	S	T	V	W	X	Y
32	142	48	94	30	29	19	27.5	22	17	6	M10x1.25	M6 depth16	13	1/8"	5.5	6	6	47	32.5	12	10	3	30
40	159	54	105	35	33	21	32	24	17	7	M12x1.25	M6 depth16	17	1/4"	6	7.5	8.5	53	38	16	13	3.5	35
50	175	69	106	40	42	27	31	32	23	8	M16x1.5	M8 depth16	15.5	1/4"	7.5	6.5	9.5	65	46.5	20	17	3.5	40
63	190	69	121	45	42	27	33	32	23	8	M16x1.5	M8 depth16	16.5	3/8"	7.5	7.5	11.5	75	56.5	20	17	4	45
80	214	86	128	45	53	33	33	40	26	10	M20x1.5	M10 depth17	16.5	3/8"	9	7.5	13.5	95	72	25	22	4	45
100	229	91	138	55	55	36	37	40	26	10	M20x1.5	M10 depth17	18.5	1/2"	9.5	8.5	13.5	115	89	25	22	4	55
125	279	119	160	60	74	45	46	54	41	13.5	M27x2.0	M12 depth20	23	1/2"	14	12	14	140	110	32	27	-	-
160	332	152	180	65	94	58	50	72	55	18	M36x2.0	M16 depth24	25	3/4"	15	12	20	180	140	40	36	-	-
200	347	167	180	75	110	57	50	72	55	18	M36x2.0	M16 depth24	25	3/4"	-	-	-	220	170	40	36	-	-
250	388	188	200	90	121	67	52	84	65	21	M42x2.0	M20 depth25	26.5	1"	20.5	7.5	21	270	220	50	45	10	90

Note: With magnet and without magnet, the dimensions are same.

VBCD

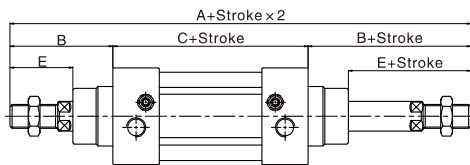

Bore/Sign	A	A1	B	C	E	Z	J	K
32	190	188	48	94	29	27	6	M10x1.25
40	213	208	54	105	33	28	7	M12x1.25
50	244	233	69	106	42	31	8	M16x1.5
63	259	248	69	121	42	31	8	M16x1.5
80	300	286	86	128	53	39	10	M20x1.5
100	320	304	91	138	55	39	10	M20x1.5
125	398	372.5	119	160	74	48.5	13.5	M27x2.0
160	484	448	152	180	94	58	18	M36x2.0
200	514	462	167	180	110	58	18	M36x2.0
250	576	531	188	200	121	76	21	M42x2.0

Note: 1. With magnet and no magnet, the dimensions are same.  
2. Not marked dimension is same as VBC standard type.  
3. LBC series dimensions are same as VBC.

VBCJ

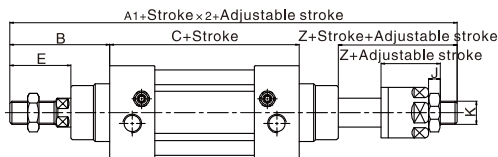

# VBC/LBC Series ISO15552 Standard Cylinder



## Dimension of Mounting Accessories

⊙LB



Bore/Sign	AA	AC	AD	AE	AF	AG	AH	AP	AT
FJ-VBC32LB	158	142	8	47	32	24	32	7	4
FJ-VBC40LB	179	161	9	53	36	28	36	9	4
FJ-VBC50LB	190	170	10	65	45	32	45	9	5
FJ-VBC63LB	209	185	12	75	50	32	50	9	5
FJ-VBC80LB	248	210	19	95	63	41	63	12.5	6
FJ-VBC100LB	258	220	19	115	75	41	71	14.5	6
FJ-VBC125LB	290	250	20	140	90	45	90	16.5	8
FJ-VBC160LB	340	300	20	180	115	60	115	18.5	10
FJ-VBC200LB	380	320	30	220	135	70	135	24	12

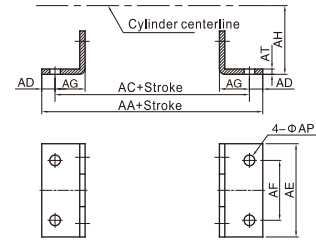

⊙FA/FB



Bore/Sign	AJ	AK	BA	BB	BC	BD	BE	BF	BH	BP	T
FJ-VBC32FA	11	7	30.5	10	47	32	80	64	6	7	32.5
FJ-VBC40FA	11	7	35.5	10	53	36	90	72	6	9	38
FJ-VBC50FA	14	9	40.5	12	65	45	110	90	8	9	46.5
FJ-VBC63FA	14	9	45.5	12	75	50	125	100	8	9	56.5
FJ-VBC80FA	17	11	45.5	16	95	63	154	126	10	12.5	72
FJ-VBC100FA	17	11	55.5	16	115	75	186	150	10	14.5	89
FJ-VBC125FA	19	13	62	20	140	90	218	180	12.5	16.5	110
FJ-VBC160FA	26	18	72	20	180	115	278	230	14.5	18.5	140
FJ-VBC200FA	26	18	82	25	220	135	318	270	17	22	175

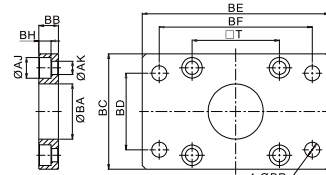

⊙CA



Bore/Sign	DA	DC	DE	DJ	DP	DQ	DZ	S	T
FJ-VBC32CA	31	22	10	9.5	7	25.8	5.5	47	32.5
FJ-VBC40CA	37	25	12	9.5	7	27.8	5.5	53	38
FJ-VBC50CA	39	27	12	10.5	9	31.8	6.5	65	46.5
FJ-VBC63CA	47	32	16	10.5	9	39.7	6.5	75	56.5
FJ-VBC80CA	51	36	16	14.5	11	49.7	10	95	72
FJ-VBC100CA	61	41	20	14.5	11	59.7	10	115	89
FJ-VBC125CA	75	50	25	17.5	13	69.7	10	140	110
FJ-VBC160CA	82.5	55	30	20	18	89.7	19	176	140
FJ-VBC200CA	88.5	60	30	25	18	89.7	24	218	175

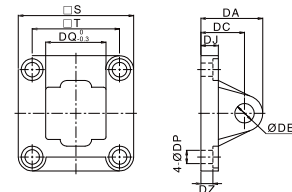

⊙CB



Bore/Sign	DA	DC	DE	DJ	DP	DQ	DT	DZ	S	T
FJ-VBC32CB	31	22	10	9.5	7	26 <sup>+0.52</sup> <sub>0</sub>	45	5.5	47	32.5
FJ-VBC40CB	37	25	12	9.5	7	28 <sup>+0.52</sup> <sub>0</sub>	52	5.5	53	38
FJ-VBC50CB	39	27	12	10.5	9	32 <sup>+0.62</sup> <sub>0</sub>	60	6.5	65	46.5
FJ-VBC63CB	47	32	16	10.5	9	40 <sup>+0.62</sup> <sub>0</sub>	70	6.5	75	56.5
FJ-VBC80CB	51	36	16	14.5	11	50 <sup>+0.62</sup> <sub>0</sub>	90	10	95	72
FJ-VBC100CB	61	41	20	14.5	11	60 <sup>+0.74</sup> <sub>0</sub>	110	10	115	89
FJ-VBC125CB	75	50	25	17.5	13	70 <sup>+0.74</sup> <sub>0</sub>	130	10	140	110
FJ-VBC160CB	82	55	30	20	18	90 <sup>+1</sup> <sub>0</sub>	163.5	19	176.5	140
FJ-VBC200CB	89.5	60	30	25	18	90 <sup>+1</sup> <sub>0</sub>	175	24	218	175

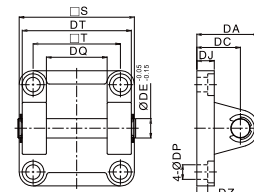

⊙CR



Bore/Sign	DC	DD	DE	DF	DJ	DQ	DM	DN	S	T
FJ-VBC32CR	32	10	10	21	8	25.8	31	18	51	38
FJ-VBC40CR	36	11	12	24	10	27.8	35	22	54	41
FJ-VBC50CR	45	13	12	33	12	31.8	45	30	65	50
FJ-VBC63CR	50	15	16	37	12	39.7	50	35	67	52
FJ-VBC80CR	63	15	16	47	14	49.7	60	40	86	66
FJ-VBC100CR	71	19	20	55	15	59.7	70	50	96	76
FJ-VBC125CR	90	22.5	25	70	20	69.7	90	60	124	94
FJ-VBC160CR	115	30	30	97	26	90	126	88	157	118
FJ-VBC200CR	135	30	30	105	31	90	130	90	162	122

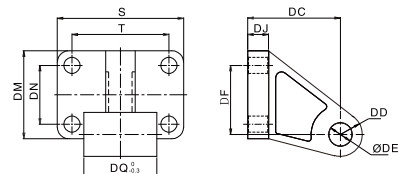

VBC/LBC

## TBC/XBC

### Standard Cylinder



### Specifications

Bore Size (mm)	32	40	50	63	80	100	125	160
Acting type	Double Acting							
Working medium	Clean Air(40 μm filtration)							
Working pressure (MPa)	0.1~1.0							
Guaranteed pressure (MPa)	1.5							
Working temperature (°C)	-20~80(No freezing)							
Speed range (mm/s)	50~800						30~500	
Cushion type	Air Cushion							
Cushion stroke (mm)	25		24		30		28	
Mounting type	LB FA FB CA CB TC							
Port size ①	G1/8		G1/4		G3/8		G1/2	G3/4

① PT, NPT port size is optional.

### How to Order?

Series No.	Cushion Type	Type No.	Bore X	Stroke-	Adjustable Stroke	Magnet No.-	Seal Material -	Mounting Type	Thread Type
	C: Air cushion		32	25	10	Blank: No magnet S: With magnet		Blank: No CA TCM CB IJ LB YJ FA YCJ FB BJ TC FD ....	Blank: G P: PT T: NPT
	TB: Round type barrel		40	50	20				
	XB: Profile barrel		50	75	30				
			63	...	40		Blank: Standard material (NBR seal) V: VITON seal		
			80		50				
	Blank: Basic type		100		75				
	D: Double shaft type		125 (Only TB is optional)		100				
	J: Double shaft and adjustable type		160 (Only TB is optional)						

Series No.	Cushion Type	Type No.	Bore X	Stroke-	Adjustable Stroke	Magnet No.-	Seal Material -	Mounting Type	Thread Type
	C: Air cushion		32	25	25	Blank: No magnet S: With magnet			Blank: G P: PT T: NPT
	TB: Round type barrel		40	50	50				
			50	75	75				
			63	...	...				
			80						
	T: Multi-position type		100						

#### Order Example:

TBC series, bore 40mm, stroke 50mm, with magnet, NBR seal, CA mounting accessory, G thread.

EPR code is: TBC40X50-S-CA

Note: If cylinder with several different mounting accessories, please use this sequential coding: CA/CB/CR/LB/FA/FB/TC/IJ/YJ/BJ/FD(TC only available for TBC)

### Optional Accessories

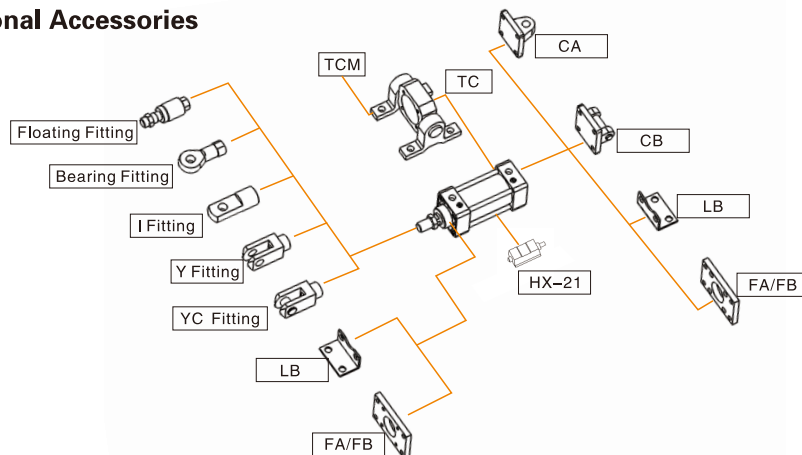

# TBC/XBC Series Standard Cylinder



## Stroke

Bore (mm)	Standard Stroke (mm)	Max. Stroke (mm)
32	25 50 75 80 100 125 150 160 175 200 250 300 350 400 450 500	1900
40	25 50 75 80 100 125 150 160 175 200 250 300 350 400 450 500 600 700 800	1900
50~160	25 50 75 80 100 125 150 160 175 200 250 300 350 400 450 500 600 700 800 900 1000	1900

## Internal Structure

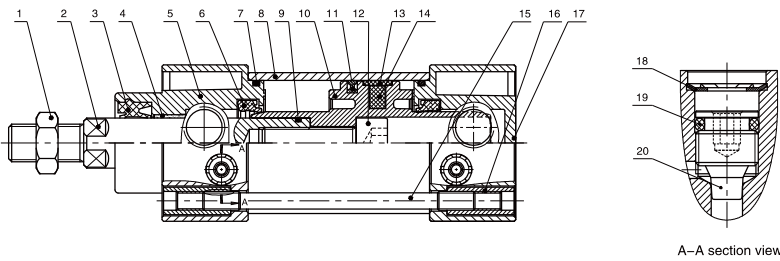

NO.	Part Name	Material
1	Nut	Carbon steel
2	Piston rod	S45C hard chrome carbon steel
3	Piston rod seal	TPU
4	Self lubricating bearing	Bronze powder
5	Head cover	Aluminum alloy
6	Cushion seal	NBR
7	O-ring	NBR
8	Barrel	Aluminum alloy
9	O-ring	NBR
10	Piston	Aluminum alloy
11	Piston seal	NBR
12	Screw	Carbon steel
13	Wear ring	PTFE
14	Magnet	Plastic
15	Tie rod	Carbon steel
16	Tie rod nut	Carbon steel
17	Rear cover	Aluminum alloy
18	Retainer ring	Spring steel
19	O-ring	NBR
20	Nut	Brass

## Main Dimension

TBC  $\Phi 32-\Phi 160$

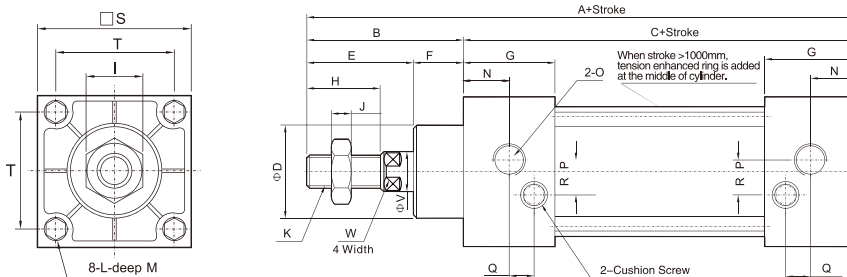

Bore/Sign	A	B	C	D	E	F	G	H	I	J	K	L
32	140	47	93	26	32	15	27.5	22	17	6	M10X1.25	M6X1
40	142	49	93	32	34	15	27.5	24	17	7	M12X1.25	M6X1
50	150	57	93	38	42	15	27.5	32	23	8	M16X1.5	M6X1
63	153	57	96	38	42	15	27.5	32	23	8	M16X1.5	M8X1.25
80	182	75	107	46	54	21	33	40	26	10	M20X1.5	M10X1.5
100	188	75	113	46	54	21	33	40	26	10	M20X1.5	M10X1.5
125	218	88	130	52	68	20	38	54	41	13.5	M27X2.0	M12X1.75
160	254	113	141	62	88	25	38	72	55	18	M36X2.0	M16X2.0

Bore/Sign	M	N	O	P	Q	R	S	T	V	W
32	13	14	1/8"	3.5	7	6.5	45	33	12	10
40	13	13.5	1/4"	5	5.5	8.5	50	37	16	14
50	13	14.5	1/4"	8.5	3	11	62	47	20	17
63	13	15	3/8"	7	5	9.5	75	56	20	17
80	15.5	16.5	3/8"	7	8	10	94	70	25	22
100	15.5	16.5	1/2"	7.5	8	13	112	84	25	22
125	19	19	1/2"	15	5	15	137.5	104	32	27
160	19.5	19	3/4"	15	6	15	173.5	134	40	36

## Main Dimension

TBCD  $\Phi 32-\Phi 160$

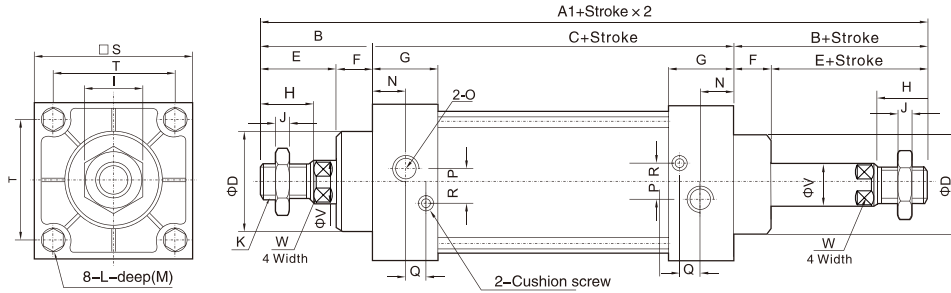

Bore/Sign	A1	B	C	D	E	F	G	H	I	J	K	L
32	187	47	93	26	32	15	27.5	22	17	6	M10X1.25	M6X1
40	191	49	93	32	34	15	27.5	24	17	7	M12X1.25	M6X1
50	207	57	93	38	42	15	27.5	32	23	8	M16X1.5	M6X1
63	210	57	96	38	42	15	27.5	32	23	8	M16X1.5	M8X1.25
80	257	75	107	46	54	21	33	40	26	10	M20X1.5	M10X1.5
100	263	75	113	46	54	21	33	40	26	10	M20X1.5	M10X1.5
125	306	88	130	52	66	20	38	54	41	13.5	M27X2.0	M12X1.75
160	367	113	141	62	88	25	38	72	55	18	M36X2.0	M16X2.0
Bore/Sign	M	N	O	P	Q	R	S	T	V	W		
32	13	14	1/8"	3.5	7	6.5	45	33	12	10		
40	13	13.5	1/4"	5	5.5	8.5	50	37	16	14		
50	13	14.5	1/4"	8.5	3	11	62	47	20	17		
63	13	15	3/8"	7	5	9.5	75	56	20	17		
80	15.5	16.5	3/8"	7	8	10	94	70	25	22		
100	15.5	16.5	1/2"	7.5	8	13	112	84	25	22		
125	19	19	1/2"	15	5	15	137.5	104	32	27		
160	19.5	19	3/4"	15	6	15	173.5	134	40	36		

Note: 1. With magnet and no magnet, the dimensions are same.  
2. XBC series dimensions are same as TBC.

TBCJ  $\Phi 32-\Phi 160$

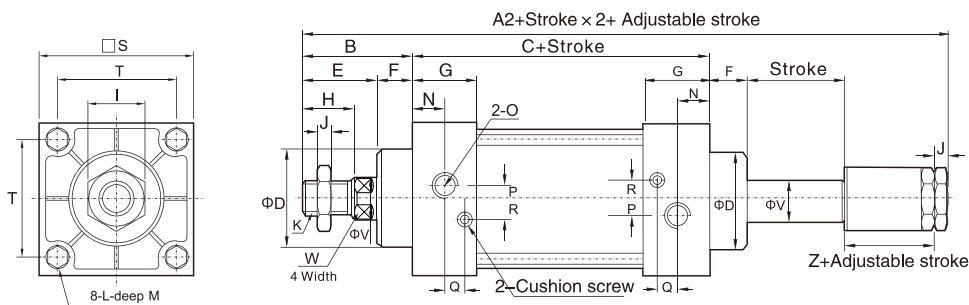

Bore/Sign	A2	B	C	D	E	F	G	H	I	J	K	L
32	182	47	93	26	32	15	27.5	22	17	6	M10X1.25	M6X1
40	185	49	93	32	34	15	27.5	24	17	7	M12X1.25	M6X1
50	196	57	93	38	42	15	27.5	32	23	8	M16X1.5	M6X1
63	199	57	96	38	42	15	27.5	32	23	8	M16X1.5	M8X1.25
80	242	75	107	46	54	21	33	40	26	10	M20X1.5	M10X1.5
100	248	75	113	46	54	21	33	40	26	10	M20X1.5	M10X1.5
125	286.5	88	130	52	68	20	38	54	41	13.5	M27X2.0	M12X1.75
160	337	113	141	62	88	25	38	72	55	18	M36X2.0	M16X2.0
Bore/Sign	M	N	O	P	Q	R	S	T	V	W	Z	
32	13	14	1/8"	3.5	7	6.5	45	33	12	10	21	
40	13	13.5	1/4"	5	5.5	8.5	50	37	16	14	21	
50	13	14.5	1/4"	8.5	3	11	62	47	20	17	23	
63	13	15	3/8"	7	5	9.5	75	56	20	17	23	
80	15.5	16.5	3/8"	7	8	10	94	70	25	22	29	
100	15.5	16.5	1/2"	7.5	8	13	112	84	25	22	29	
125	19	19	1/2"	15	5	15	137.5	104	32	27	35	
160	19.5	19	3/4"	15	6	15	173.5	134	40	36	40	

# TBC/XBC Series Standard Cylinder



## ◎ Main Dimension

TBCT  $\Phi 32$ - $\Phi 100$

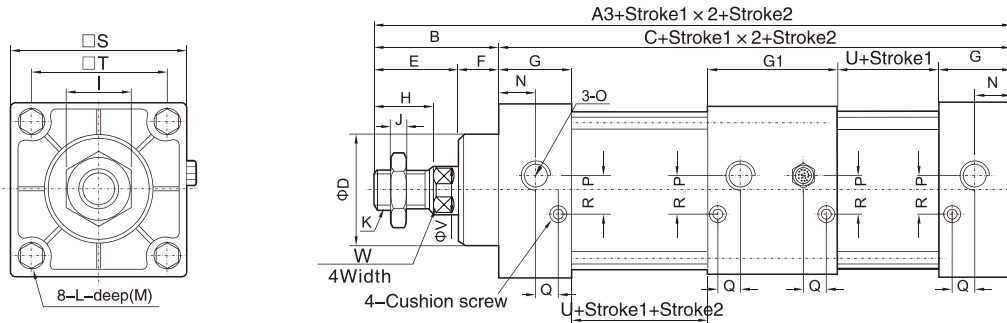

Bore/Sign	A3	B	C	D	E	F	G	G1	H	I	J	K	L
32	233	47	186	26	32	15	27.5	55	22	17	6	M10X1.25	M6X1
40	235	49	186	32	34	15	27.5	55	24	17	7	M12X1.25	M6X1
50	243	57	186	38	42	15	27.5	55	32	23	8	M16X1.5	M6X1
63	249	57	192	38	42	15	27.5	55	32	23	8	M16X1.5	M8X1.25
80	296	75	221	46	54	21	33	73	40	26	10	M20X1.5	M10X1.5
100	308	75	233	46	54	21	33	73	40	26	10	M20X1.5	M10X1.5
Bore/Sign	M	N	O	P	Q	R	S	T	V	U	W		
32	13	14	1/8"	3.5	7	6.5	45	33	12	38	10		
40	13	13.5	1/4"	5	5.5	8.5	50	37	16	38	14		
50	13	14.5	1/4"	8.5	3	11	62	47	20	38	17		
63	13	15	3/8"	7	5	9.5	75	56	20	41	17		
80	15.5	16.5	3/8"	7	8	10	94	70	25	41	22		
100	15.5	16.5	1/2"	7.5	8	13	112	84	25	47	22		

## Dimension of Mounting Accessories

◎LB



Bore/Sign	AA	AC	AD	AE	AF	AG	AH	AP	AT
FJ-TBC32LB	153	132	10.5	50	33	19.5	28	9	3
FJ-TBC40LB	169	140	14.5	57	36	23.5	30	12	3
FJ-TBC50LB	173	149	11.5	68	47	28.5	36.5	12	3
FJ-TBC63LB	184	158	13	80	56	32	41	12	3
FJ-TBC80LB	199	167	16	97	70	29	49	14	4
FJ-TBC100LB	209	173	18	112.5	84	30	57	14	4

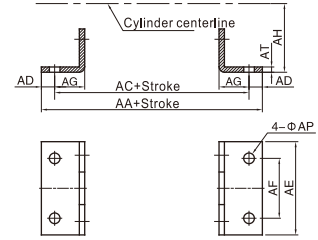

◎FA/FB



Bore/Sign	AJ	AK	BA	BB	BC	BD	BE	BF	BH	BP	T
FJ-TBC32FA	11	7	28.5	10	47	33	72	58	6.5	7	33
FJ-TBC40FA	11	7	32.5	10	52	36	84	70	6.5	7	37
FJ-TBC50FA	11	7	38.5	10	65	47	104	86	6.5	9	47
FJ-TBC63FA	14	9	38.5	12	73	56	115	98	8.5	9	56
FJ-TBC80FA	17	11	47.5	16	92	70	141	119	10.5	11	70
FJ-TBC100FA	17	11	47.5	16	113	84	160	138	10.5	11	84

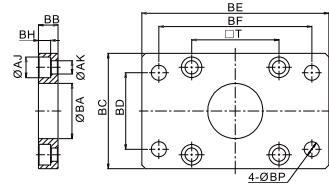

◎CA



Bore/Sign	DA	DC	DE	DJ	DP	DQ	DZ	S	T
FJ-TBC32CA	48	34	12	10	7	16	5.5	44	33
FJ-TBC40CA	48.5	34	14	10.5	7	20	5.5	49.5	37
FJ-TBC50CA	48.5	33	14	10.5	7	20	6.5	62	47
FJ-TBC63CA	50	34	14	10.5	9	20	6.5	72	56
FJ-TBC80CA	66.5	48	20	13	11	32	10	92	70
FJ-TBC100CA	65.5	48.5	20	13	11	32	10	110	84

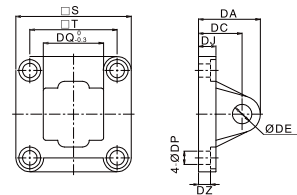

◎CB



Bore/Sign	DA	DC	DE	DJ	DP	DQ	DT	S	T
FJ-TBC32CB	32.5	19.5	12	10	7	16.5	32.5	47	33
FJ-TBC40CB	32.5	19.5	14	10.5	7	20.5	44	50	37
FJ-TBC50CB	34	19	14	10.5	7	20.5	52	62	47
FJ-TBC63CB	34	22	14	10	9	20.5	52	72	56
FJ-TBC80CB	50	32	20	13	11	32.5	64	93	70
FJ-TBC100CB	51	32	20	13.5	11	32.5	64	110	84

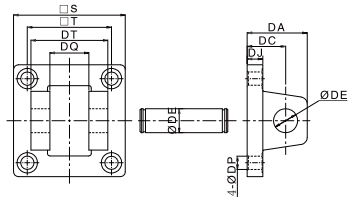

◎TC



Bore/Sign	EA	EB	EC	EE	EP	ET	T
FJ-TBC32TC	38	89	54	55	16	31	33
FJ-TBC40TC	46	116	65	63	25	30.5	37
FJ-TBC50TC	56	127	76	75	25	29	47
FJ-TBC63TC	69.5	140.5	90	88	25	31	56
FJ-TBC80TC	87.5	165	107	114	25	36	70
FJ-TBC100TC	107.5	181	131	132	25	41	84

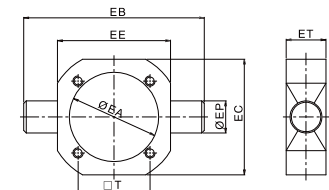

◎TCM



Bore/Sign	HA	HB	HD	HP	HT	HQ	HJ
FJ-TBC32TCM	110.5	80	16	12	13	21.5	51
FJ-TBC40/50/63TCM	111.5	80	25.5	12	10.5	21	50.5
FJ-TBC80/100TCM	110	85	25.5	14	15	20.5	71

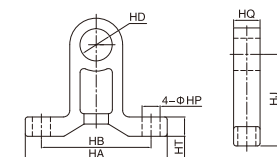

# IA/IAC Series ISO6432 Mini Type Cylinder



## IA/IAC Mini Type Cylinder



### Specifications

Bore size(mm)	8	10	12	16	20	25
Acting type	Double Acting/Single Acting					
Working medium	Clean Air(40 μ m filtration)					
Working pressure (MPa)	0.1~0.7(Double Acting) / 0.2~0.7(Single Acting)			0.1~1.0(Double Acting) / 0.2~1.0(Single Acting)		
Guaranteed pressure (MPa)	1.5					
Working temperature (°C)	-20~80(No freezing)					
Speed range (mm/s)	Double Acting: 30~800			Single Acting:50~800		
Cushion type	Rubber cushion			Rubber cushion(Standard) / Air cushion(Optional)		
Barrel material	Stainless steel					
Mounting type	LB FA SDB					
Port size	M5 x 0.8				G1/8①	

① PT、NPT port size is optional.

### How to Order?

Series No	Cushion Type	Type No	Bore	X	Stroke	Adjustable Stroke	Magnet No	Tail Type	Mounting Type	Thread Type	
IA: Stainless steel barrel	C: Air Cushion Blank: Rubber Cushion	Blank: Basic type D: Double shaft type J: Double shaft and adjustable stroke type SA: Single action extend type SB: Single action return type	8								
			10	25	10	Blank: No Magnet	Blank: No	Blank: G			
			12	50	20	S: With Magnet	LB	P: PT			
			16	75	30		FA	T: NPT			
			20	...	40	Blank: Swiveling tail	SDB				
			25	50	U: Flat tail	TC					
		75	CM: Round tail	IJ							
		100		YJ							
				BJ							
				....							

#### Order Example:

IA series, Double shaft and adjustable stroke type, air cushion, bore 20mm, stroke 25mm, adjustable stroke 20, with magnet, no mounting type, round tail, PT thread.

ERP code is: IACJ20\*25-20-S-CM-P

Note: 1.If cylinder with several different mounting accessories, please use this sequential coding: LB/FA/SDB /IJ/YJ/BJ

2.IA Series,Bore 8mm and Bore 10mm,No round tail type is optional.

3.IAC Series,Φ16、Φ20、Φ25 is optional.

### Optional Accessories

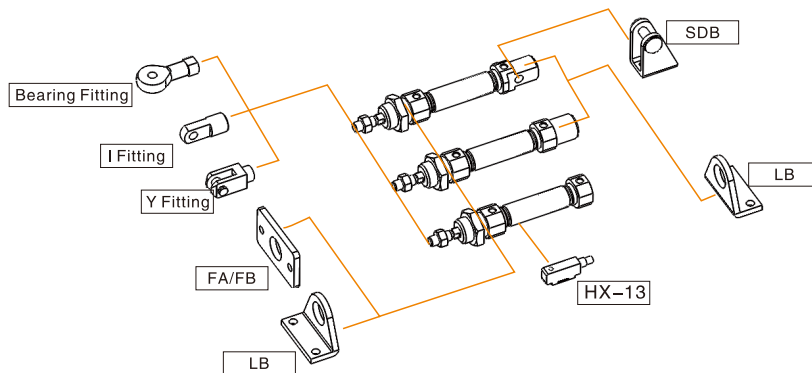

## Stroke

Bore (mm)	Standard Stroke (mm)	Max. Stroke (mm)
Double Acting	8	25 50 75 100 125 150
	10	25 50 75 100 125 150 175 200
	12	25 50 75 100 125 150 175 200 225 250
	16	25 50 75 100 125 150 175 200 225 250 300 350 400 500
	20~25	25 50 75 100 125 150 175 200 225 250 300 350 400 500
Single Acting	8	10 15 20 25 30 40 50
	10	10 15 20 25 30 40 50
	12	10 15 20 25 30 40 50
	16	10 15 20 25 30 40 50 60 75 80 100
	20~25	10 15 20 25 30 40 50 60 75 80 100 125 150

## Internal Structure

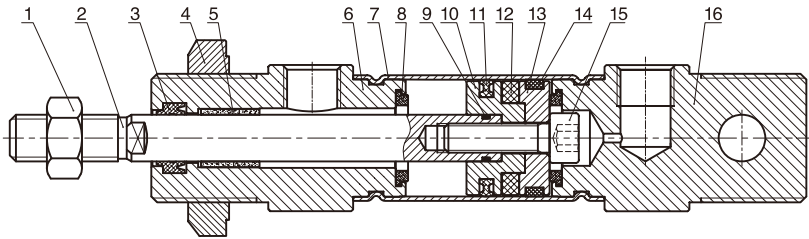

NO.	Part name	Material
1	Nut	Carbon steel
2	Piston rod	IA8、10:SUS304hard chrome carbon steel / IA12-IA25:S45C hard chrome carbon steel
3	Piston rod seal	NBR
4	Nut	Carbon steel
5	Self lubricating bearing	Bronze powder
6	Head cover	Aluminum alloy
7	Barrel	Stainless Steel
8	Anti-bump cushion	TPU
9	O-ring	NBR
10	Piston	IA8、10: Stainless steel / IA12-IA25: Aluminum alloy
11	Piston seal	NBR
12	Magnet	Plastic
13	Magnet base	IA8、10: Stainless steel / IA12-IA25: Aluminum alloy
14	Wear ring	PTFE
15	Hexagon screw	Carbon steel
16	Rear cover	Aluminum alloy

# IA/IAC Series ISO6432 Mini Type Cylinder



## ◎ Main Dimension

### IA Φ8-Φ25

#### CA Type

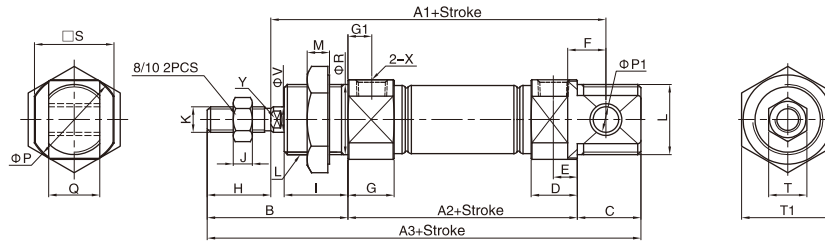

#### CM Type

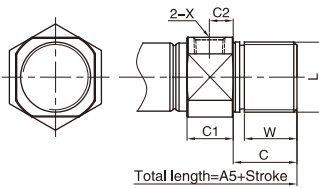

#### U Type

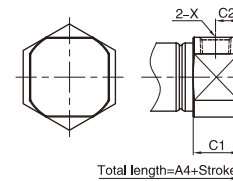

Bore/Sign	(mm)																								
	A1	A2	A3	A4	A5	B	C	C1	C2	D	E	F	G	G1	H	I	J	K	L	M	P	P1	Q	R	S
8	64	46	86	74	-	28	12	9.5	5	9.5	5.2	6	11.5	7	12	12	3	M4X0.7	M12X1.25	7	17	4	8	12	15
10	64	46	86	74	-	28	12	9.5	5	9.5	5.2	6	11.5	7	12	12	3	M4X0.7	M12X1.25	7	17	4	8	12	15
12	75	50	105	88	105	38	17	10	5	10	5	9	12	7	16	17	5	M6X1.0	M16X1.5	6	19.7	6	12	16	18.3
16	82	56	111	94	111	38	17	10.5	5.5	10.5	5.5	9	12.5	7	16	17	5	M6X1.0	M16X1.5	6	22	6	12	16	20
20	95	62	126	106	126	44	20	14.5	7.5	14.5	7.5	12	14.5	7.5	20	20	6	M8X1.25	M22X1.5	7	29	8	16	22	25
25	104	65	137	115	137	50	22	16	8	16	8	12	16	8	22	22	6	M10X1.25	M22X1.5	7	33.5	8	16	22	30

Bore/Sign	T	T1	X	V	W	Y
8	7	17	M5X0.8	4	-	-
10	7	17	M5X0.8	4	-	-
12	10	22	M5X0.8	6	15	5
16	10	22	M5X0.8	6	15	5
20	12	29	1/8"	8	18	6
25	17	29	1/8"	10	20	8

Note: With magnet and no magnet, the dimensions are same.

### IAD Φ8-Φ25

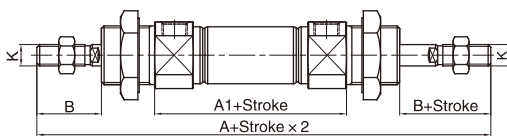

### IAJ Φ8-Φ25

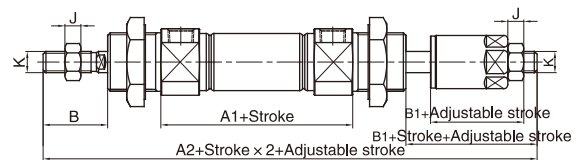

Bore/Sign	A	A1	A2	B	B1	J	K
8	104	48	103.5	16	15.5	3	M4X0.7
10	104	48	103.5	16	15.5	3	M4X0.7
12	128	52	128	21	21	5	M6X1.0
16	134	58	134	21	21	5	M6X1.0
20	150	62	151	24	25	6	M8X1.25
25	165	65	164	28	27	6	M10X1.25

Note: Unlabeled the same size as standard type.

## Main Dimension

### IAC $\Phi 16-\Phi 25$

#### CA Type

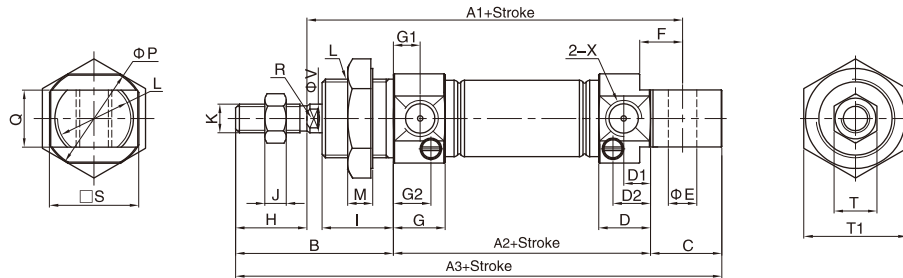

#### CM Type

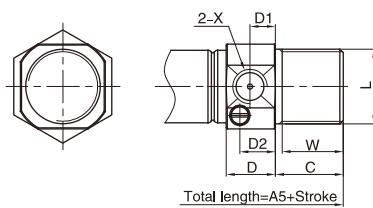

#### U Type

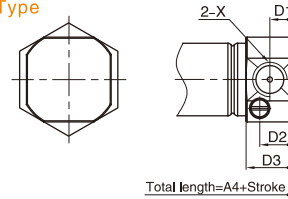

(mm)

Bore:Sign	A1	A2	A3	A4	A5	B	C	D	D1	D2	D3	E	F	G	G1	G2	H	I	J	K	L	M	P	Q	R
16	82	56	111	94	111	38	17	12	6	9	12	6	9	12.5	7	9.5	16	17	5	M6X1.0	M16X1.5	6	22	12	5
20	95	62	126	106	126	44	20	14.5	7.5	11	14.5	8	12	14.5	7.5	11	20	20	6	M8X1.25	M22X1.5	7	29	16	6
25	104	65	137	115	137	50	22	16	8	12.5	16	8	12	16	8	12.5	22	22	6	M10X1.25	M22X1.5	7	33.5	16	8

Bore:Sign	S	T	T1	X	V	W
16	20	10	22	M5X0.8	6	15
20	25	12	29	1/8"	8	18
25	30	17	29	1/8"	10	20

Note: With magnet and no magnet, the dimensions are same.

### IACD $\Phi 16-\Phi 25$

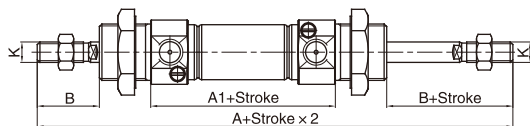

### IACJ $\Phi 16-\Phi 25$

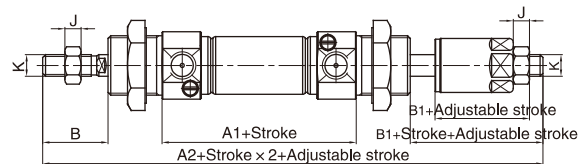

Bore:Sign	A	A1	A2	B	B1	J	K
16	132.5	56.5	132.5	21	21	5	M6X1.0
20	150	62	151	24	25	6	M8X1.25
25	165	65	164	28	27	6	M10X1.25

Note: Unlabeled the same size as standard type.

# IA/IAC Series ISO6432 Mini Type Cylinder



## Main Dimension

### IASB $\Phi 12-\Phi 25$

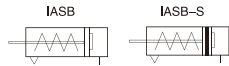

#### CA Type

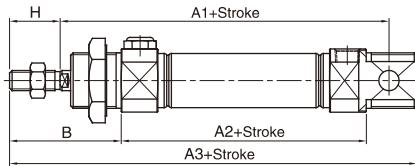

#### CM Type

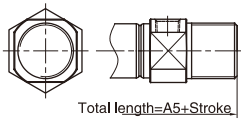

#### U Type

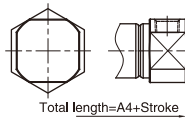

### IASA $\Phi 12-\Phi 25$

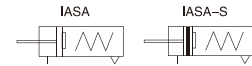

#### CA Type

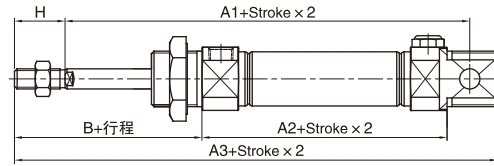

#### CM Type

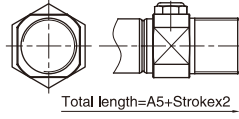

#### U Type

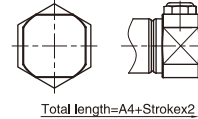

Bore\Sign	A1			A2			A3			A4			A5			B	H
	0-50	51-100	101-150	0-50	51-100	101-150	0-50	51-100	101-150	0-50	51-100	101-150	0-50	51-100	101-150		
12	100	-	-	75	-	-	130	-	-	113	-	-	130	-	-	38	16
16	107	132	-	81	106	-	136	161	-	119	144	-	136	161	-	38	16
20	120	145	170	87	112	137	151	176	201	131	156	181	151	176	201	44	20
25	129	154	179	90	115	140	162	187	212	140	165	190	162	187	212	50	22

Note: Unlabeled the same size as standard type.

## Accessory Dimensions

### LB Accessory

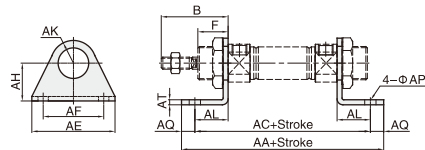

Model\Sign	AA	AC	AE	AF	AH	AK	AL	AP	AQ	AT	B	F
FJ-IA12LB	88	76	42	32	20.5	12.5	13	6	6	4	38	17
FJ-IA16LB	94	82	42	32	20.5	12.5	13	6	6	4	38	17
FJ-IA20LB	114	98	54	40	22.5	20	18	7	8	4	44	20
FJ-IA25LB	117	101	54	40	22.5	20	18	7	8	4	50	22

### FA Accessory

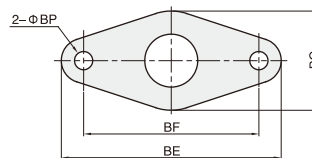
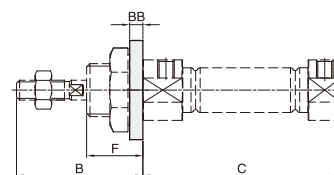

Model\Sign	B	C	BB	BC	BE	BF	F
FJ-IA12FA	38	50	4	30	53	40	17
FJ-IA16FA	38	56	4	30	53	40	17
FJ-IA20FA	44	62	5	40	66	50	20
FJ-IA25FA	50	65	5	40	66	50	22

### SDB Accessory

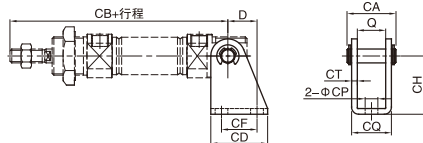

Model\Sign	D	Q	CA	CB	CD	CF	CH	CP	CQ	CT
FJ-IA12SDB	13	12.1	21.5	91	25	15	27	5.5	17.1	2.5
FJ-IA16SDB	13	12.1	21.5	98	25	15	27	5.5	17.1	2.5
FJ-IA20SDB	16	16.1	29	115	32	20	30	6.6	24.1	4
FJ-IA25SDB	16	16.1	29	126	32	20	30	6.6	24.1	4

## RAL

### Mini Type Cylinder



### Specifications

Bore size(mm)	16	20	25	32	40	50	63
Acting type	Double Acting/Single Acting						
Working medium	Clean Air(40 μ m filtration)						
Working pressure (MPa)	0.1~0.7(Double Acting) 0.2~0.7(Single Acting)		0.1~1.0(Double Acting) / 0.2~1.0(Single Acting)				
Guaranteed pressure (MPa)	1.5						
Working temperature (°C)	-20~80(No freezing)						
Speed range (mm/s)	Double Acting: 30~800			Single Acting:50~800			
Cushion type	Rubber cushion / Air cushion						
Barrel material	Aluminum alloy						
Mounting type	LB FA SDB						
Port size	M5 x 0.8	G1/8 ①			G1/4 ①		

① PT, NPT port size is optional.

### How to Order?

Series No	Cushion Type	Type No	Bore	X	Stroke	Adjustable Stroke	Magnet No	Tail Type	Mounting Type	Thread Type
RAL	C: Air cushion Blank: Rubber cushion		16 20 25 32 40 50 63		25 50 75 ...	10 20 30 40 50 75 100	Blank: No magnet S: With magnet	Blank: Swiveling tail U: Flat tail J CM: Round tail (CM is not available for Φ50, Φ63 series)	Blank: No LB FA SDB IJ YJ BJ ....	Blank: G P: PT T: NPT

Blank: Basic type  
D: Double shaft type  
J: Double shaft and adjustable stroke type  
SA: Single action extend type  
SB: Single action return type

#### Order Example:

RAL series, Double shaft and adjustable stroke type, air cushion, Bore 32mm, stroke 25mm, Adjustable stroke 20, with magnet, No Mounting type, Round tail, PT thread.  
ERP code is: RALCJ32\*25-20-S-CM-P

Note: If cylinder with several different mounting accessories, pls with this sequential coding: LB/FA/SDB /IJ/YJ/BJ

### Optional Accessories

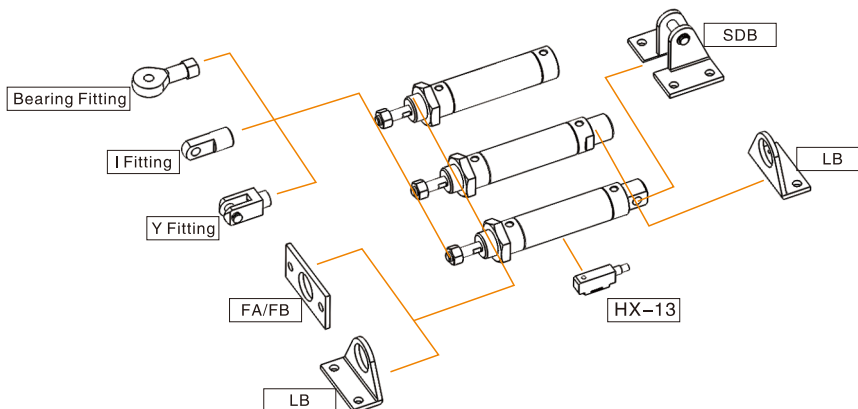

# RAL Series Mini Type Cylinder



## Stroke

	Bore (mm)	Standard Stroke (mm)	Max. Stroke (mm)
Double Acting	16~20	25 50 75 80 100 125 150 160 175 200 250 300	800
	25~63	25 50 75 80 100 125 150 160 175 200 250 300 350 400 450 500	800
Single Acting	16	25 50 75 100	100
	20~40	25 50 75 100 125 150	150

## Internal Structure

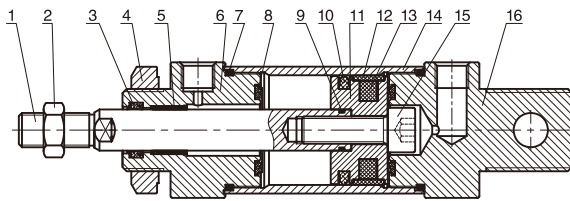

No.	Part Name	Material
1	Piston rod	S45C hard chrome carbon steel
2	Nut	Carbon steel
3	Piston rod seal	NBR
4	Nut	Carbon steel
5	Self lubricating bearing	Bronze powder
6	Head cover	Aluminum alloy
7	O-ring	NBR
8	Anti-bump cushion	TPU
9	O-ring	NBR
10	Piston seal	NBR
11	Piston	Aluminum alloy
12	Wear ring	PTFE
13	Magnet	Plastic
14	Barrel	Aluminum alloy
15	Hexagon screw	Carbon steel
16	Rear cover	Aluminum alloy

## Main Dimension

RAL  $\phi 16-\phi 63$

CA Type

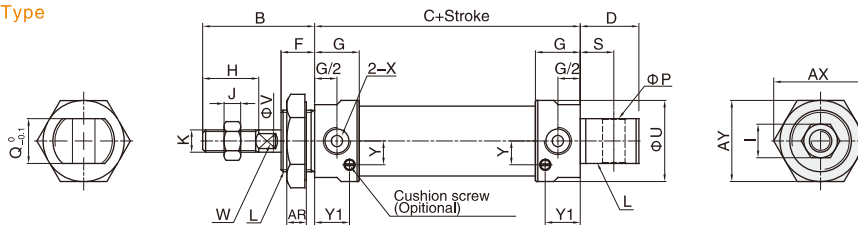

CM Type (CM is not available for  $\phi 50, \phi 63$  series)

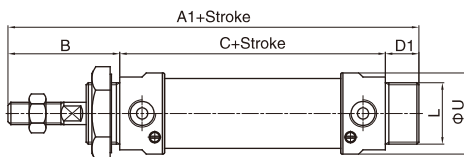

U Type

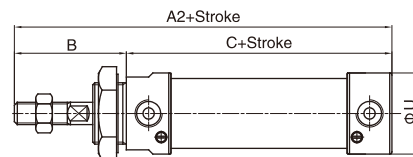

Bore\Sign	A1	A2	B	C	D	D1	F	G	H	I	J	K	L	P	Q	S	U	V	W	X	AR	AX	AY	Y	Y1
16	102	92	36	56	14	10	14	11	16	10	5	M6X1.0	M16X1.5	6	12	7	20	6	5	M5X0.8	6	25	22	6.3	8
20	122	110	40	70	21	12	12	16	20	12	6	M8X1.25	M22X1.5	8	16	12	29	8	6	1/8"	7	33	29	8.5	12.5
25	128	114	44	70	21	14	14	16	22	17	6	M10X1.25	M22X1.5	8	16	12	34	10	8	1/8"	7	33	29	10	12.5
32	128	114	44	70	27	14	14	16	22	17	6	M10X1.25	M24X2.0	10	16	15	39.5	12	10	1/8"	8	37	32	12	12
40	152	138	46	92	27	14	14	22	24	17	7	M12X1.25	M30X2.0	12	20	15	49.5	16	14	1/4"	9	47	41	16	18
50	146	146	54	92	27	22	22	24	24	19	8	M14X1.5	M36X2.0	12	20	16	55	20	18	1/4"	11	53	48	13.6	14
63	146	146	54	92	27	22	22	24	24	19	8	M14X1.5	M36X2.0	12	20	16	69	20	18	1/4"	11	53	48	19.8	14

Note: With magnet and no magnet, the dimensions are same.

## Main Dimension

RALD  $\Phi 16-\Phi 40$

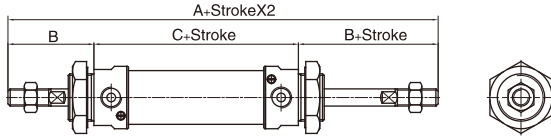

RALJ  $\Phi 16-\Phi 40$

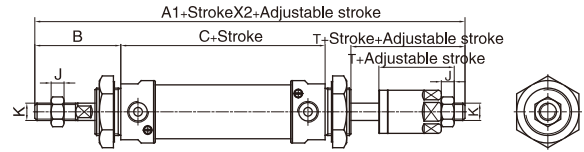

Bore\Sign	A	A1	B	C	J	K	T
16	128	127	36	56	5	M6X1.0	21
20	150	147	40	70	6	M8X1.25	25
25	158	155	44	70	6	M10X1.25	27
32	158	155	44	70	6	M10X1.25	27
40	184	180	46	92	7	M12X1.25	28

Note: Unlabeled the same size as standard type.

RALSB  $\Phi 16-\Phi 40$

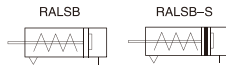

CA Type

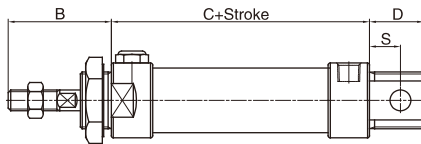

CM Type

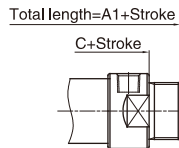

U Type

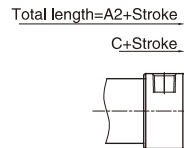

RALSA  $\Phi 16-\Phi 40$



CA Type

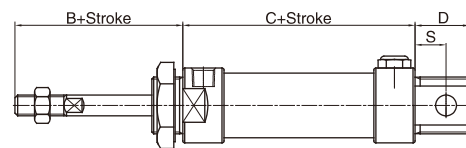

CM Type

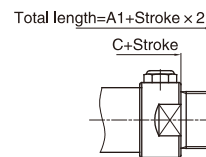

U Type

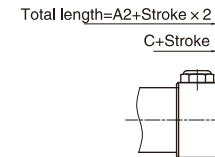

Bore\Sign	A1			A2			C			B	D	S
	0-50	51-100	101-150	0-50	51-100	101-150	0-50	51-100	101-150			
16	127	152	-	117	142	-	81	106	-	36	14	7
20	147	172	197	135	160	185	95	120	145	40	21	12
25	153	178	203	139	164	189	95	120	145	44	21	12
32	153	178	203	139	164	189	95	120	145	44	27	15
40	177	202	227	163	188	213	117	142	167	46	27	15

Note: Unlabeled the same size as standard type.

# RA Series Mini Type Cylinder



## RA

### Mini Type Cylinder

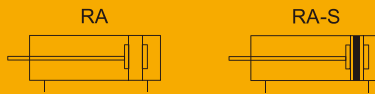

### Specifications



Bore size(mm)	16	20	25	32	40	50	63
Acting type	Double Acting/Single Acting						
Working medium	Clean Air(40 μ m filtration)						
Working pressure (MPa)	0.1~0.7(Double Acting) 0.2~0.7(Single Acting)		0.1~1.0(Double Acting) / 0.2~1.0(Single Acting)				
Guaranteed pressure (MPa)	1.5						
Working temperature (°C)	-20~80(No freezing)						
Speed range (mm/s)	Double Acting: 30~800			Single Acting:50~800			
Cushion type	Rubber cushion / Air cushion						
Barrel material	Aluminum alloy						
Mounting type	LB FA SDB						
Port size	M5 × 0.8	G1/8 ①			G1/4 ①		

① PT、NPT port size is optional.

### How to Order?

Series No	Cushion Type	Type No	Bore	X	Stroke	Adjustable Stroke	Magnet No	Tail Type	Mounting Type	Thread Type
RA	C: Air cushion Blank: Rubber cushion (Rubber cushion is not available for Φ 50, Φ 63)		16 20 25 32 40 50 63		25 50 75 ...	10 20 30 40 50 75 100	S: With magnet	Blank: Swiveling tail U: Flat tail CM: Round tail	Blank: No LB FA SDB IJ YJ BJ ....	Blank: G P: PT T: NPT
		Blank: Basic type D: Double shaft type J: Double shaft and adjustable stroke type SA: Single action extend type SB: Single action return type								

#### Order Example:

RA series, Double shaft and adjustable stroke type, air cushion, bore 32mm, stroke 25mm, adjustable stroke 20, with magnet, no mounting type, round tail, PT thread.

ERP code is: RACJ32\*25-20-S-CM-P

Note: 1. If cylinder with several different mounting accessories, please with this sequential coding: LB/FA/SDB /J/YJ/BJ

2. RA series always with magnet.

### Optional Accessories

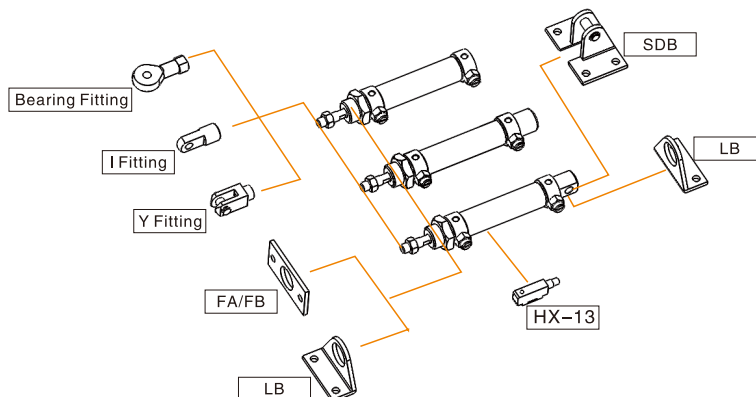

## Stroke

Bore (mm)		Standard Stroke (mm)	Max. Stroke (mm)
Double Acting	16	25 50 75 80 100 125 150 160 175 200	500
	20	25 50 75 80 100 125 150 160 175 200 250 300	600
	25~63	25 50 75 80 100 125 150 160 175 200 250 300 350 400 450 500	800
Single Acting	16	25 50 75 100	100
	20~40	25 50 75 100 125 150	150

## Internal Structure

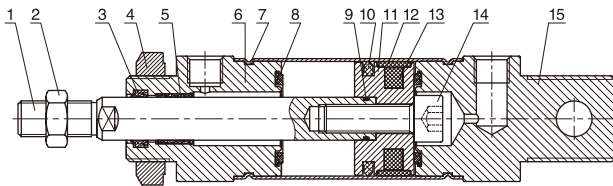

No.	Part Name	Material
1	Piston rod	S45C hard chrome carbon steel
2	Nut	Carbon steel
3	Piston rod seal	NBR
4	Nut	Carbon steel
5	Self lubricating bearing	Bronze powder
6	Head cover	Aluminum alloy
7	Barrel	Stainless Steel
8	Anti-bump cushion	TPU
9	O-ring	NBR
10	Piston seal	NBR
11	Piston	Aluminum alloy
12	Wear ring	PTFE
13	Magnet	Plastic
14	Hexagon screw	Carbon steel
15	Rear cover	Aluminum alloy

## Main Dimension

RA  $\phi 16$ – $\phi 63$

CA Type

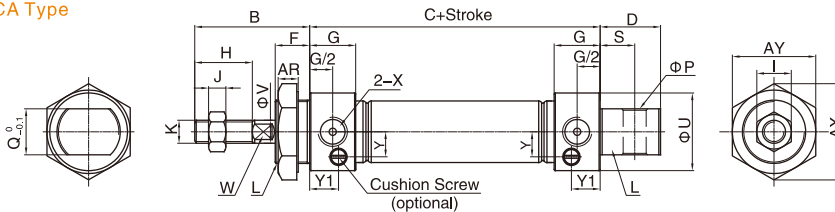

CM Type

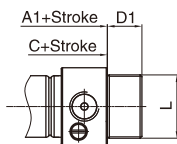

U Type

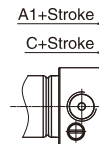

Bore\Sign	A1	B	C	D	D1	F	G	H	I	J	K	Y1	L	P	Q	S	U	V	W	X	AX	AY	Y
16	98	38	60	16	16	16	10	16	10	5	M6X1.0	7	M16X1.5	6	12	9	21	6	5	M5X0.8	25	22	6.5
20	116	40	76	21	12	12	16	20	12	6	M8X1.25	12.5	M22X1.5	8	16	12	27	8	6	1/8"	33	29	8
25	120	44	76	21	14	14	16	22	17	6	M10X1.25	12.5	M22X1.5	8	16	12	30	10	8	1/8"	33	29	10
32	120	44	76	27	14	14	16	22	17	6	M10X1.25	12	M24X2.0	10	16	15	35	12	10	1/8"	37	32	12
40	122	46	76	27	14	14	17	24	17	7	M12X1.25	13	M30X2.0	12	20	15	42	16	14	1/8"	47	41	16
50	147	52	95	27	20	20	23	24	19	8	M14X1.25	11.5	M36X2.0	12	20	16	53	20	18	1/4"	53	48	26.5
63	147	52	95	27	20	20	23	24	19	8	M14X1.25	11.5	M36X2.0	12	20	16	66	20	18	1/4"	53	48	33

Note: 1. With magnet and no magnet, the dimensions are same.

2. Rubber cushion is not available for  $\phi 50$ ,  $\phi 63$ .

# RA Series Mini Type Cylinder



## Main Dimension

### RAD $\Phi 16-\Phi 40$

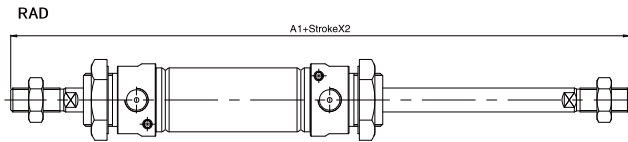

### RAJ $\Phi 16-\Phi 40$

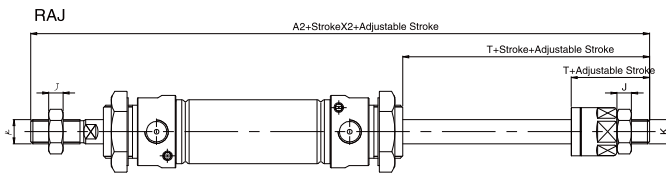

Bore\Sign	A1	A2	J	K	T
16	136	135	5	M6X1.0	21
20	156	153	6	M8X1.25	25
25	164	161	6	M10X1.25	27
32	164	161	6	M10X1.25	27
40	168	164	7	M12X1.25	28

Note: Unlabeled the same size as standard type.

### RASB $\Phi 16-\Phi 40$

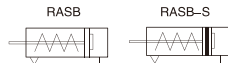

#### CA Type

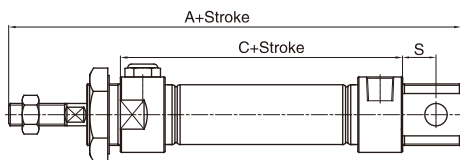

#### CM Type

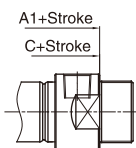

#### U Type

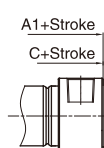

### RASA $\Phi 16-\Phi 40$



#### CA Type

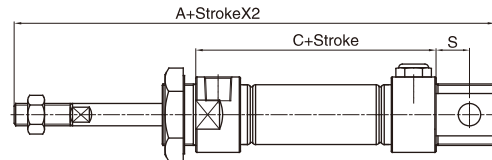

#### CM Type

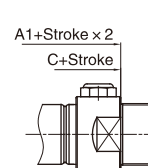

#### U Type

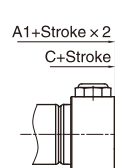

Bore\Sign	A			A1			C			S
	0-50	51-100	101-150	0-50	51-100	101-150	0-50	51-100	101-150	
16	139	164	-	123	148	-	85	110	-	9
20	162	187	212	141	166	191	101	126	151	12
25	166	191	216	145	170	195	101	126	151	12
32	172	197	222	145	170	195	101	126	151	15
40	174	199	224	147	172	197	101	126	151	15

Note: Unlabeled the same size as standard type.

## Main Dimension

### LB

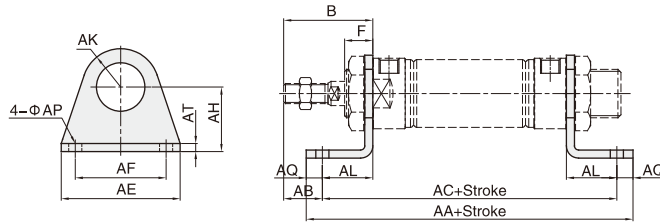

Bore\Sign	B		F		AA		AA(RALSB)			AA(RASB)			AB	
	RAL	RA	RAL	RA	RAL	RA	0-50	51-100	101-150	0-50	51-100	101-150	RAL	RA
FJ-RA16LB	36	38	14	16	96	100	121	146	-	125	150	-	22	24
FJ-RA20LB	40	40	12	12	118	124	143	168	193	149	174	199	24	24
FJ-RA25LB	44	44	14	14	118	124	143	168	193	149	174	199	28	28
FJ-RA32LB	44	44	14	14	138	144	163	188	213	169	194	219	18	18
FJ-RA40LB	46	46	14	14	162	146	187	212	237	171	196	221	19	19

Bore\Sign	AC		AC(RALSB)			AC(RASB)			AE	AF	AH	AK	AL	AP	AQ	AT
	RAL	RA	0-50	51-100	101-150	0-50	51-100	101-150								
FJ-RA16LB	84	88	109	134	-	113	138	-	44	32	20	14	14	5.5	6	3
FJ-RA20LB	102	108	127	152	177	133	158	183	54	40	25	17	16	6.5	8	3
FJ-RA25LB	102	108	127	152	177	133	158	183	54	40	25	17	16	6.5	8	3
FJ-RA32LB	122	128	147	172	197	153	178	203	59	45	32	19	26	6.5	8	3
FJ-RA40LB	146	130	171	196	221	155	180	205	64	50	36	23	27	6.5	8	3

### FA

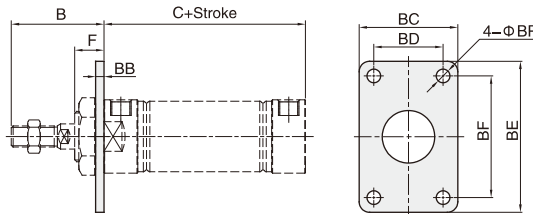

Bore\Sign	B		C		C(RALSB)			C(RASB)			BB	BC	BD	BE	BF	BP	F	
	RAL	RA	RAL	RA	0-50	51-100	101-150	0-50	51-100	101-150							RAL	RA
FJ-RA16FA	36	38	56	60	81	106	-	85	110	-	3	26	-	52	40	5.5	14	16
FJ-RA20FA	40	40	70	76	95	120	145	101	126	151	4	33	-	64	50	6.5	12	12
FJ-RA25FA	44	44	70	76	95	120	145	101	126	151	4	33	-	64	50	6.5	14	14
FJ-RA32FA	44	44	70	76	95	120	145	101	126	151	4	47	33	72	58	6.5	14	14
FJ-RA40FA	46	46	92	76	117	142	167	101	126	151	4	50	36	84	70	6.5	14	14

### SDB

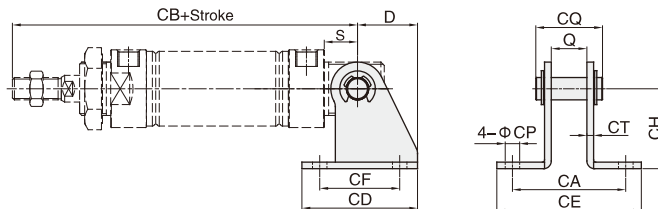

Bore\Sign	D	S		Q	CA	CB		CB(RALSB)			CB(RASB)			CD	CE	CF	CH	CP	CQ	CT
		RAL	RA			RAL	RA	0-50	51-100	101-150	0-50	51-100	101-150							
FJ-RA16SDB	18	7	9	12.1	42.1	99	107	124	149	-	132	157	-	36	55.1	24	25.5	5.5	22.5	3
FJ-RA20SDB	24.5	12	12	16.1	51.1	122	128	147	172	197	153	178	203	48	66.1	32	32	6.5	27	3
FJ-RA25SDB	24.5	12	12	16.1	51.1	126	132	151	176	201	157	182	207	48	66.1	32	32	6.5	27	3
FJ-RA32SDB	27	15	15	16.1	50.1	129	135	154	179	204	160	185	210	52	65.1	36	35.5	6.5	27.5	3
FJ-RA40SDB	27	15	15	20.1	52.1	153	137	178	203	228	162	187	212	56	69.1	40	40	6.5	32.5	3

# SJ Series Stainless Steel Mini Cylinder



## SJ

### Mini Type Cylinder



### Specifications

Bore size(mm)	6	10	12	16
Acting type	Double Acting			
Working medium	Clean Air(40 μ m filtration)			
Working pressure (MPa)	0.1~0.7			
Guaranteed pressure (MPa)	1.0			
Working temperature (°C)	-20~80(No freezing)			
Speed range (mm/s)	50~750			
Cushion type	Rubber cushion on both ends			
Port size	M5x0.8			

### How to Order?

Series No.	Type No.	Bore X Stroke	Magnet No.	Tail Type
SJ	Blank: Basic type D: Double shaft type J: Double shaft and adjustable stroke type	6 10 12 16	10 15 20 ...	Blank: No magnet S: With magnet U: Flat tail (Radial intake type) CB: Double U-type (Radial intake type) CM: Round tail (Radial intake type) R: Axial intake type (Note: Only U or R optional for Ø6)

#### Order Example:

SJ series cylinder, basic type, 10mm bore, 50mm stroke, with magnet, flat tail, the ERP code is: SJ10x50-S-U

### Optional Accessories

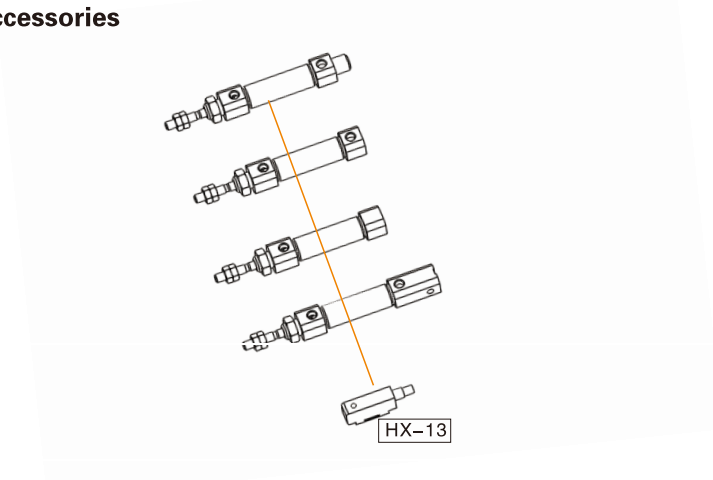

### Stroke

	Bore (mm)	Standard Stroke (mm)	Max. Stroke (mm)
	Double Acting	6	10 15 20 25 30 40 50 60
10		10 15 20 25 30 40 50 60 75 80 100 125 150	150
12		10 15 20 25 30 40 50 60 75 80 100 125 150 160 175 200	200
16		10 15 20 25 30 40 50 60 75 80 100 125 150 160 175 200	200

3

SJ

## Internal Structure

SJØ6

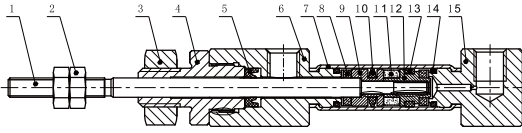

No.	Part name	Material
1	Piston rod	S45C hard chrome carbon steel
2	Nut	Carbon steel
3	Nut	Carbon steel
4	Piston seal	NBR
5	Head cover	Aluminum alloy
6	Barrel	Stainless steel
7	Anti-bump cushion	TPU
8	Piston	Ø10:SUS304 Ø16: Aluminum alloy
9	Piston seal	NBR
10	Magnet	RbFeB
11	Magnet Base	Ø10:SUS304 Ø16: Aluminum alloy
12	Wear ring	PTFE
13	Anti-bump cushion	TPU
14	O-ring	NBR
15	Rear cover	Aluminum alloy

SJØ10、Ø12、Ø16

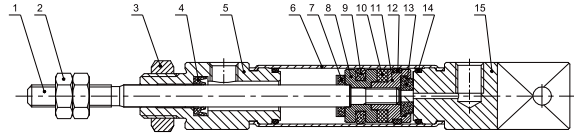

No.	Part name	Material
1	Piston rod	S45C hard chrome carbon steel
2	Nut	Carbon steel
3	Nut	Carbon steel
4	Head cover dust ring	NBR
5	Head cover	Aluminum alloy
6	Barrel	Stainless steel
7	Anti-bump cushion	TPU
8	Piston	Ø10:SUS304 Ø16: Aluminum alloy
9	Piston seal	NBR
10	Magnet	RbFeB
11	Magnet Base	Ø10:SUS304 Ø16: Aluminum alloy
12	Wear ring	PTFE
13	Anti-bump cushion	TPU
14	O-ring	NBR
15	Rear cover	Aluminum alloy

## Main Dimension

SJØ6

U Type

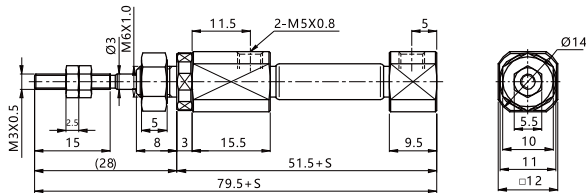

R Type

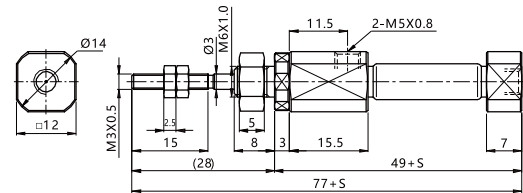

SJØ10、Ø12、Ø16

CB Type

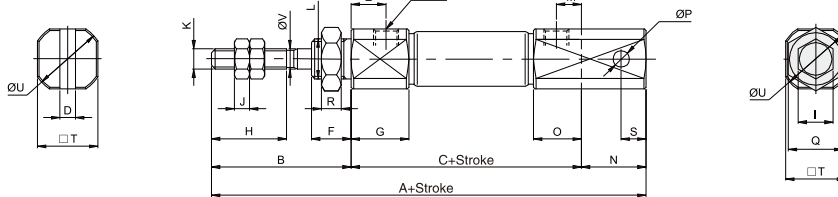

U Type

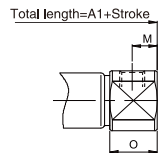

CM Type

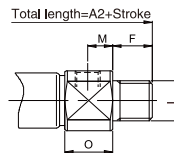

R Type

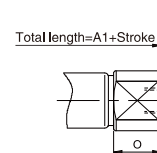

Bore\Sign	A	A1	A2	B	C	D	E	F	G	H	I	J	K	L	M	N	O	P	Q	R	S	T	U	V	X
10	87	74	82	28	46	3.2	7	8	11.5	15	7	3	M4X0.7	M8X1.0	5	13	9.5	3.3	11	4	5	12	14	4	M5X0.8
12	92	74	82	28	46	6.5	7.5	8	12	15	8	4	M5X0.8	M10X1.0	5	18	9.5	5	14	4	8	15	17	5	M5X0.8
16	93	75	83	28	47	6.5	7.5	8	12.3	15	8	4	M5X0.8	M10X1.0	5	18	9.5	5	14	4	8	18.3	19.7	5	M5X0.8

# SM Series Stainless Steel Mini Cylinder



## SM

### Mini Type Cylinder

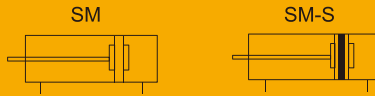

### Specifications



Bore size(mm)	20	25	32	40
Acting type	Double Acting/Single Acting			
Working medium	Clean Air(40 μ m filtration)			
Working pressure (MPa)	0.1~1.0(Double Acting) / 0.2~1.0(Single Acting)			
Guaranteed pressure (MPa)	1.5			
Working temperature (°C)	-20~80(No freezing)			
Speed range (mm/s)	Double Acting: 30~800		Single Acting:50~800	
Cushion type	Rubber cushion / Air cushion			
Barrel material	Aluminum alloy			
Mounting type	LB FA SDB			
Port size	G1/8 ①			G1/4 ①

① PT、NPT port size is optional.

### How to Order?

Series	Cushion Type	Type Code	Bore X Stroke	Adjustable Stroke	Magnet Code	Tail Type	Mounting Type	Thread Type
SM	C: Air cushion Blank: Rubber cushion		20 25 32 40	25 50 75 ...	10 20 30 40 50 75 100	Blank: No magnet S: With magnet	Blank: No bracket LB FA SDB IJ YJ	Blank: G P: PT T: NPT
		Blank: Basic type D: Double -shaft type J: Double -shaft, adjustable stroke type SA: Single acting spring extend SB: Single acting spring return				Blank: Swiveling tail U: Flat tail CM: Round tail		

#### Order Example:

SM series double shaft adjustable stroke cylinder, air cushion, bore 32mm, stroke 25mm, adjustable stroke 20mm, with magnet, no bracket, round tail, PT thread. The ERP code is: SMCJ32x25-20-S-CM-P

Note: There are many mounting types, you can chose LB/FA/SDB/IJ/YJ  
LB and Rear FA are not available for Swiveling tail.

### Optional A

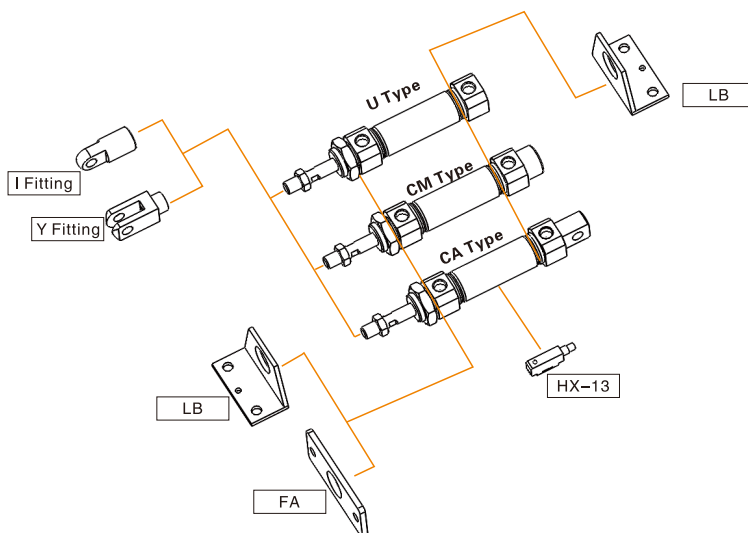

## Stroke

Bore (mm)		Standard Stroke (mm)	Max. Stroke (mm)
Double Acting	20	10 15 20 25 30 40 50 60 75 80 100 125 150 160 175 200 250 300 400 500	600
	25~40	10 15 20 25 30 40 50 60 75 80 100 125 150 160 175 200 250 300 400 500 600	800
Single Acting	20	10 15 20 25 30 40 50 60 75 80 100 125 150	150
	25~40	10 15 20 25 30 40 50 60 75 80 100 125 150	150

## Internal Structure

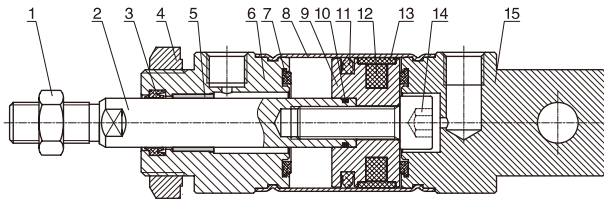

No.	Part Name	Material
1	Nut	Carbon Steel
2	Piston rod	S45C hard chrome carbon steel
3	Piston rod seal	NBR
4	Nut	Carbon Steel
5	Self lubricating Bearing	Bronze Powder
6	Head cover	Aluminum Alloy
7	Anti-bump cushion	TPU
8	Barrel	Stainless steel
9	Piston	Aluminum Alloy
10	O-ring	NBR
11	Piston seal	NBR
12	Magnet	Plastic
13	Wear ring	PTFE
14	Hexagon screw	Carbon steel
15	Rear cover	Aluminum Alloy

## Main Dimension

SM  $\Phi 20$ – $\Phi 40$

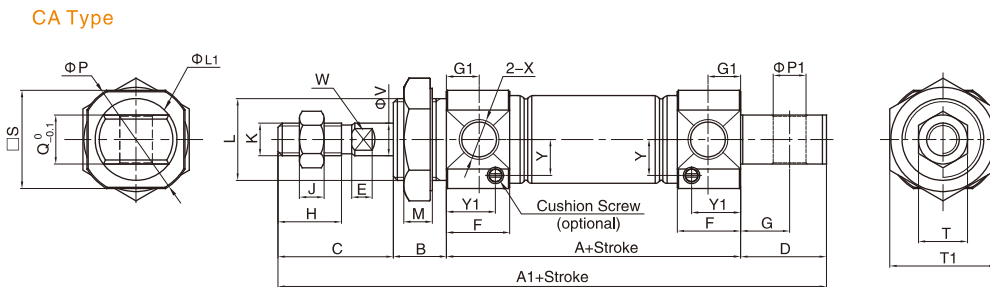

CA Type

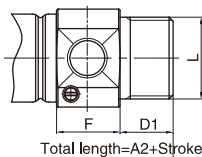

CM Type

U Type

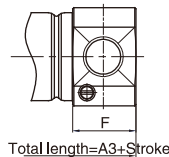

Bore/Sign	A	A1	A2	A3	B	C	D	D1	E	F	G	G1	H	J	K	L	L1	M	P	P1	Q	S	T	T1	X	V	W	Y	Y1
20	62	124	116	103	13	28	21	13	5	15.5	12	8	15.5	6	M8X1.25	M20X1.5	20	7	28	8	12	24	12	26	1/8"	8	6	8.8	12
25	62	128	120	107	13	32	21	13	5.5	15	12	8	19.5	6	M10X1.25	M26X1.5	22	8	33.5	8	12	30	17	32	1/8"	10	8	10	11.5
32	64	136	122	109	13	32	27	13	5.5	15	15	8	19.5	6	M10X1.25	M26X1.5	26	8	37.5	10	20	34.5	17	32	1/8"	12	10	12	11
40	88	165	154	138	16	34	27	16	7	22	15	11	21	8	M14X1.5	M32X2.0	32	9	46.5	10	20	42.5	19	41	1/4"	16	14	16	18

Note: With magnet and without magnet, the dimensions are same.

# SM Series Stainless Steel Mini Cylinder



## ◎ Main Dimension

SMD  $\Phi 20-\Phi 40$

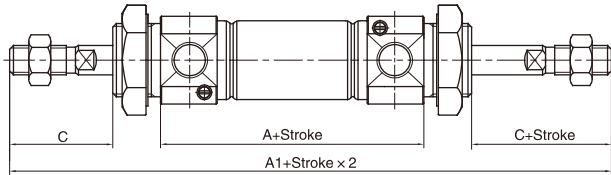

Bore\Sign	A	A1	A2	C	C1	J	K
20	62	144	141	28	25	6	M8X1.25
25	62	152	147	32	27	6	M10X1.25
32	64	154	149	32	27	6	M10X1.25
40	88	188	182	34	28	7	M12X1.25

Note: Unlabeled the same size as standard type.

SMJ  $\Phi 20-\Phi 40$

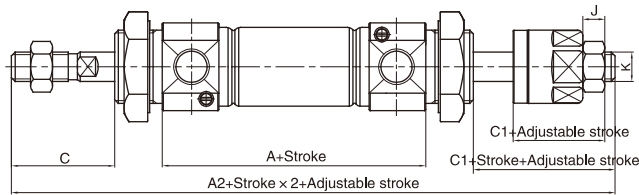

SMSB  $\Phi 20-\Phi 40$



CA Type

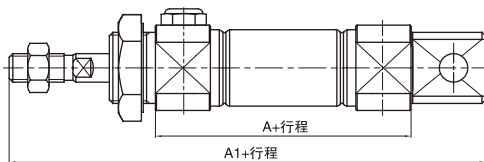

CM Type

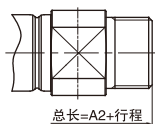

U Type

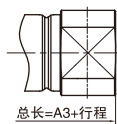

SMSA  $\Phi 20-\Phi 40$

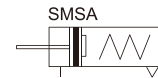

CA Type

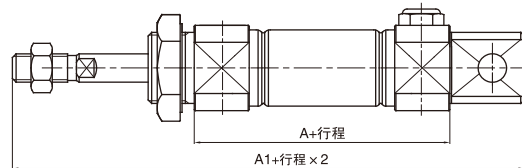

CM Type

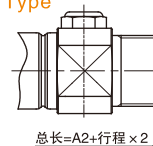

U Type



Bore\Sign	A			A1			A2			A3		
	0-50	51-100	101-150	0-50	51-100	101-150	0-50	51-100	101-150	0-50	51-100	101-150
20	87	112	137	149	174	199	141	166	191	128	153	178
25	87	112	137	153	178	203	145	170	195	132	157	182
32	89	114	139	161	186	211	147	172	197	134	159	184
40	113	138	163	190	215	240	179	204	229	163	188	213

Note: Unlabeled the same size as standard type.

## Accessory Dimensions

### LB

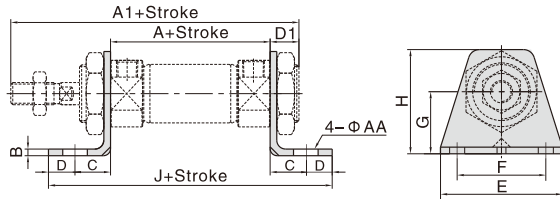

Bore/Sign	A	A1	AA	B	C	D	D1	E	F	G	H	J
FJ-SM20LB	62	116	7	3	20	8	13	55	40	25	40	118
FJ-SM25LB	62	120	7	3	20	8	13	55	40	28	47	118
FJ-SM40LB	88	154	7	3	23	10	16	75	55	30	54	154

Note: Φ 32 series borrowed Φ 25 series

### FA

Φ 20- Φ 32

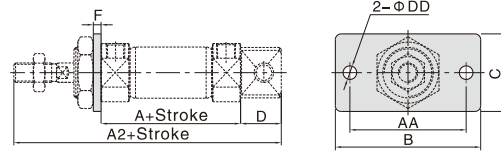

Φ 40

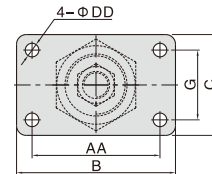

Bore/Sign	A	A2	AA	B	C	D	DD	F	G
FJ-SM20FA	62	124	60	75	34	21	7	4	-
FJ-SM25FA	62	128	60	75	40	21	7	4	-
FJ-SM40FA	88	165	66	82	52	27	7	5	36

Note: Φ 32 series borrowed Φ 25 series

### SDB

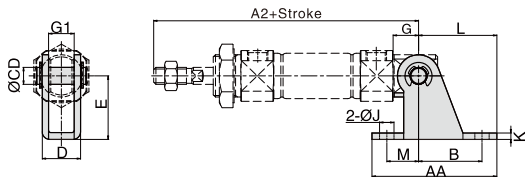

Bore/Sign	A2	AA	B	D	E	G	G1	CD	K	J	L	M
FJ-SM20SDB	115	59	30	18.1	30	12	12.1	8	3	6.8	37	15
FJ-SM32SDB	124	75	40	28.1	40	15	20.1	10	4	9	50	15

Note: Φ 25 series borrowed Φ 20 series  
Φ 40 series borrowed Φ 32 series

# EG Series Repairable Cylinder



## EG

### Mini Type Cylinder



### Specifications

Bore Size(mm)	20	25	32	40	50	63	
Acting type	Double Acting						
Working medium	Clean air(40 μ m filtration)						
Pressure range(MPa)	0.1~1.0MPa(15~145psi)(1.0~10.0bar)						
Garanteed pressure(MPa)	1.5MPa(215psi)(15bar)						
Working temperature(°C)	-20~80(No freezing)						
Speed range(mm/s)	50~1000						
Stroke range	+1.4 0						
Cushion type	Rubber cushion(Standard)/Air cushion						
Port size	M5	G1/8"			G1/4"		
Kinetic energy J	Male thread on piston rod	0.28	0.41	0.66	1.20	2.00	3.40
	Female thread on piston rod	0.11	0.18	0.29	0.52	0.91	1.54

### How to Order?

Series No	Type No	Bore	X Stroke	Magnet No	Piston Rod Thread Type	Thread Type
EG	Blank: Basic type D: Double shaft type C: Air cushion type	20 25 32 40 50 63	25 50 75 100 ...	Blank: No magnet S: With magnet	Blank: Female thread M: Male thread N: No thread	Blank: G P: PT T: NPT

#### Order Example:

EG Series basic type cylinder, 25mm bore, 50mm stroke, with magnet, male thread on piston rod, G thread.

ERP code is: EG25X50-S-M

### Optional Accessories

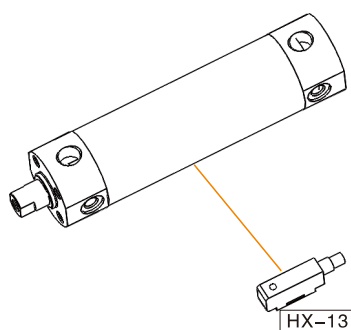

### Stroke

Bore (mm)	Standard Stroke (mm)	Max. Stroke (mm)	
Double Acting	20	25 50 75 100 125 150 175 200	201~1200
	25	25 50 75 100 125 150 175 200 250 300	301~1200
	32	25 50 75 100 125 150 175 200 250 300	301~1500
	40	25 50 75 100 125 150 175 200 250 300	301~1500
	50	25 50 75 100 125 150 175 200 250 300	301~1500
	63	25 50 75 100 125 150 175 200 250 300	301~1500

## Internal Structure

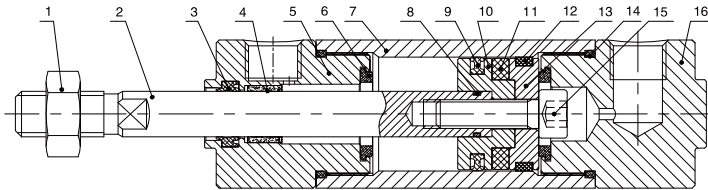

No.	Part Name	Material
1	Nut	Carbon steel(Nickel plating)
2	Piston rod	Stainless steel(EG20、25)
		Carbon steel(EG32、40、50、63)
3	Piston rod seal	TPU
4	Self-lubricating bearing	Compound material
5	Head cover	Aluminum alloy
6	Anti-bump cushion	TPU
7	Barrel	Aluminum alloy
8	O-ring	NBR
9	Piston seal	NBR(Japanese brand)
10	Piston	Aluminum alloy
		RbFeB(EG20、25)
11	Magnet	Plastic(EG32、40、50、63)
		PTFE
12	Wear ring	PTFE
13	Magnet base	Aluminum alloy
14	O-ring	NBR
15	Hex cylinder head screw	Carbon steel(Black)
16	Rear cover	Aluminum alloy

## Main Dimension

EG

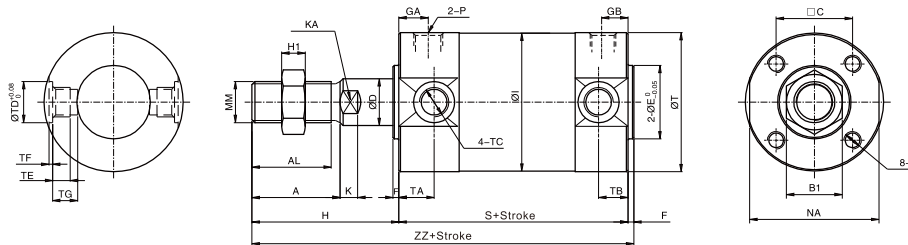

Bore	Standard Stroke Range	Long Stroke Range	A	AL	B1	C	D	E	F	H	I	J	K	KA	MM	NA
20	≤200	201~1200	18	15.5	12	14	8	12	2	35	26	M4X0.7depth7	5.5	6	M8X1.25	24
25	≤300	301~1200	22	19.5	17	16.5	10	14	2	40	31	M5X0.8depth7.5	6	8	M10X1.25	29
32	≤300	301~1500	22	19.5	17	20	12	18	2	40	38	M5X0.8depth8	6	10	M10X1.25	35.5
40	≤300	301~1500	30	27	19	26	16	25	2	50	47	M6X1.0depth12	6.5	14	M14X1.5	44
50	≤300	301~1500	35	32	27	32	20	30	2	58	58	M8X1.25depth16	7.5	18	M18X1.5	55
63	≤300	301~1500	35	32	27	38	20	32	2	58	72	M10X1.5depth16	7.5	18	M18X1.5	69

Bore	Standard Stroke Range	Long Stroke Range	P	S	GA	GB	T	H1	TA	TB	ZZ	TD	TF	TE	TG	TC
20	≤200	201~1200	M5X0.8	69(77)	13.5	13.5	26.5	6	11	11	106(114)	8	0.5	4	5.5	M5X0.8
25	≤300	301~1200	1/8"	69(77)	10	10	31.5	6	11	11	111(119)	10	1	5	6.5	M6X0.75
32	≤300	301~1500	1/8"	71(79)	10.5	9.5	38.5	6	11	10	113(121)	12	1	5.5	7.5	M8X1.0
40	≤300	301~1500	1/8"	78(87)	11.5	10	47.5	8	12	10	130(139)	14	1.25	6	8.5	M10X1.25
50	≤300	301~1500	1/4"	90(102)	13	13	58.5	11	13	12	150(162)	16	2	7.5	10	M12X1.25
63	≤300	301~1500	1/4"	90(102)	14	12	72.5	11	13	12	150(162)	18	3	11.5	14.5	M14X1.5

- Note:1、With magnet and without magnet,the dimensions are same.  
 2、Within the "( )" size is the size of long stroke;  
 3、G、PT、NPT port size is optional.

### Dimension of Female Thread

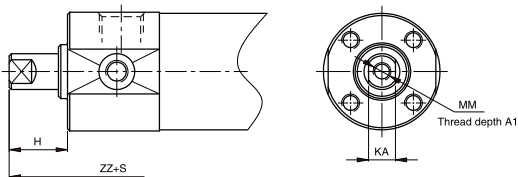

Bore/Sign	A1	H	MM	ZZ	KA
20	8	13	M4X0.7	84(92)	6
25	8	14	M5X0.8	85(93)	8
32	12	14	M6X1.0	87(95)	10
40	13	15	M8X1.25	95(104)	14
50	18	16	M10X1.5	108(120)	18
63	18	16	M10X1.5	108(120)	18

- Note:1、This figure is dimension of female thread;  
 2、Other dimensions are same as male thread.

### Dimension of Double Shaft

EGD

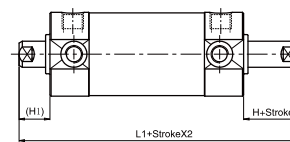
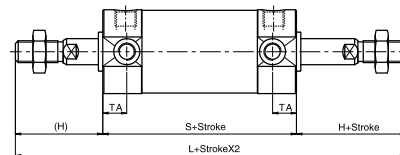

Bore/Sign	S	H	H1	L	L1	TA
20	77	35	13	147	103	11
25	77	40	14	157	105	11
32	79	40	14	159	107	11
40	87	50	15	187	117	12
50	102	58	16	218	134	13
63	102	58	16	218	134	13

# SF Series ISO21287 Compact Cylinder



## SF

### Compact Cylinder



### Specifications

Bore Size(mm)	20	25	32	40	50	63	80	100
Acting type	Double Acting/Single Acting							
Working medium	Clean Air(40 μ m filtration)							
Working pressure(MPa)	0.1~1.0(Double acting) / 0.2~1.0(Single acting)(MPa)							
Guaranteed pressure(MPa)	1.5(MPa)							
Working temperature(°C)	-20~80(No freezing)							
Speed range(mm/s)	30~500							
Cushion type	Rubber cushion							
Port size	M5X0.8				G1/8			

① NPT、PT port size is optional.

### How to Order?

Series No	Type No	Bore	X	Stroke	Adjustable Stroke	Magnet No	Piston Rod Thread Type	Thread Type
SF	Blank: Basic type D: Double shaft type J: Double shaft and adjustable stroke type SA: Single acting spring extend SB: Single acting spring return	20 25 32 ... 100		5 10 15 20 ...	10 20 30 40 50 75 100	Blank: No magnet S: With magnet	Blank: Female thread M: Male thread	Blank: G P: PT T: NPT

#### Order Example:

SF Series basic cylinder, 25mm bore, 50mm stroke, with magnet, male thread on piston rod, G thread  
ERP code is: SF25X50-S-M

### Optional Accessories

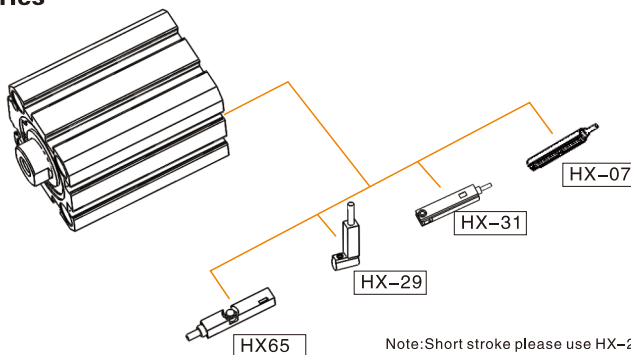

Note: Short stroke please use HX-29 series due to limited space.

### Stroke

Bore (mm)		Standard Stroke (mm)														Max. Stroke (mm)			
Double Acting	20/25	5	10	15	20	25	30	35	40	45	50	60	80	100	125	150	150		
	32~63	5	10	15	20	25	30	35	40	45	50	60	80	100	125	150		175	200
	80/100	10	15	20	25	30	35	40	45	50	60	80	100	125	150	175		200	
Single Acting	20~63	5	10	15	20	25												25	

Note: The dimensions of non-std stroke cylinder has the same dimensions as the next longer stroke std. stroke cylinder.  
e.g. 27mm stroke cylinder has the same dimensions of 30 std. stroke cylinder.  
When ordering stroke is larger than the maximum stroke, please contact us.

3  
SF

## Internal Structure

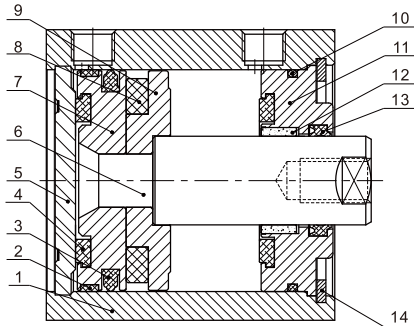

No.	Part Name	20	25	32	40	50	63	80	100	
1	Barrel	Aluminum alloy								
2	Wear ring	No				PTEE				
3	Piston seal	NBR								
4	Anti-bump cushion	TPU				NBR				
5	Rear cover	Aluminum alloy								
6	Piston rod	Stainless steel			Carbon steel					
7	Piston	Aluminum alloy								
8	Magnet	RbFeB			Plastic					
9	Magnet base	Aluminum alloy								
10	O-ring	NBR								
11	Head cover	Aluminum alloy								
12	Bearing	No			Bronze powder					
13	Piston rod seal	TPU								
14	C type retainer ring	Spring steel								

## Main Dimension

Φ20、Φ25

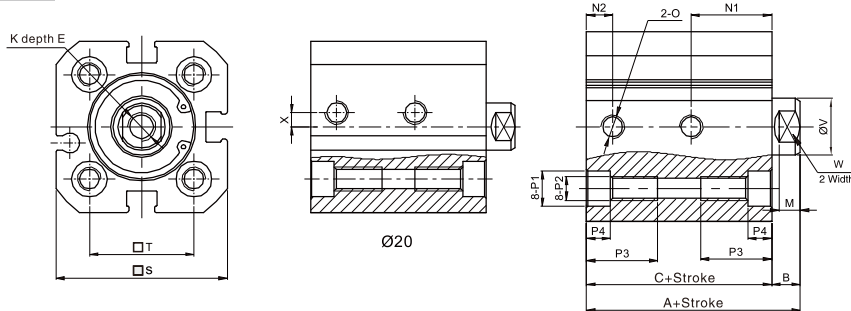

Bore/Sign	A	C	N1	N2	B	E	M	K	O	P1	P2	P3	P4	S	T	X	V	W
20	43	37	15	5.5	6	10	4	M6X1.0	M5X0.8	Φ7.3	M5X0.8	15	5	36	22	3	10	8
25	45	39	17	5.5	6	10	4.5	M6X1.0	M5X0.8	Φ7.3	M5X0.8	15	5	40	26	-	12	10

Φ32、Φ40

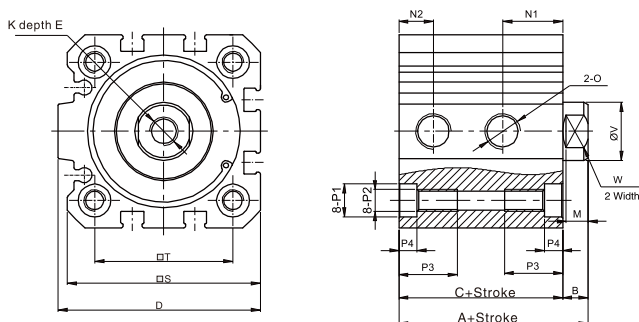

Bore/Sign	A	C	N1	N2	B	D	E	M	K
32	51	44	15	8	7	48	12	6	M8X1.25
40	52	45	16.5	9.5	7	55.5	12	6	M8X1.25
Bore/Sign	O	P1	P2	P3	P4	S	T	V	W
32	1/8"	Φ9	M6X1.0	16	5	45.5	32.5	16	14
40	1/8"	Φ9	M6X1.0	16	5	53	38	16	14

Φ50~Φ100

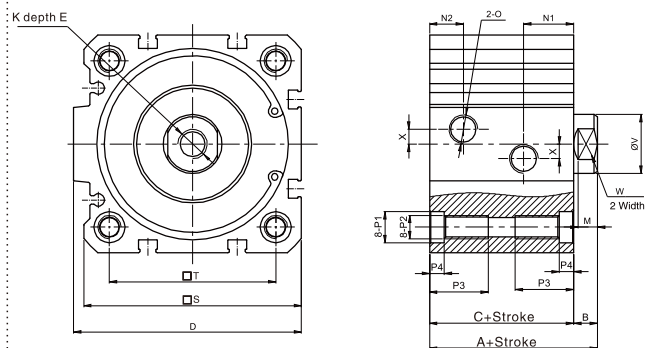

Bore/Sign	A	C	N1	N2	B	D	E	M	K	
50	53	45	16	10.5	8	65.5	16	6.5	M10X1.5	
63	57	49	17	11.5	8	77.5	16	6.5	M10X1.5	
80	64	54	17	15	10	95.5	21	8.5	M12X1.75	
100	77	67	21.5	19	10	113.5	21	8	M12X1.75	
Bore/Sign	O	P1	P2	P3	P4	S	T	X	V	W
50	1/8"	Ø10.5	M8X1.25	20	5	63	46.5	4	20	17
63	1/8"	Ø10.5	M8X1.25	20	5	74	56.5	5	20	17
80	1/8"	Ø13.7	M10X1.5	25	5	92	72	10	25	22
100	1/8"	Ø13.7	M10X1.5	25	5	109	89	14	32	27

Note: With magnet and no magnet, the dimensions are same.

# SF Series ISO21287 Compact Cylinder



## ◎ Main Dimension

### SFD

#### Φ20、Φ25

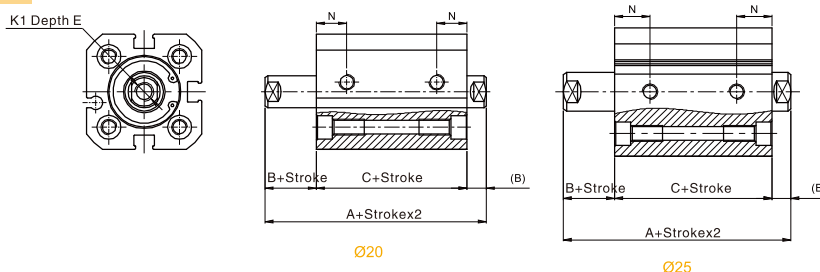

Bore/Sign	A	B	C	N	K1	E
20	49	6	37	9.5	M6X1.0	10
25	51	6	39	11	M6X1.0	10

#### Φ32、Φ40

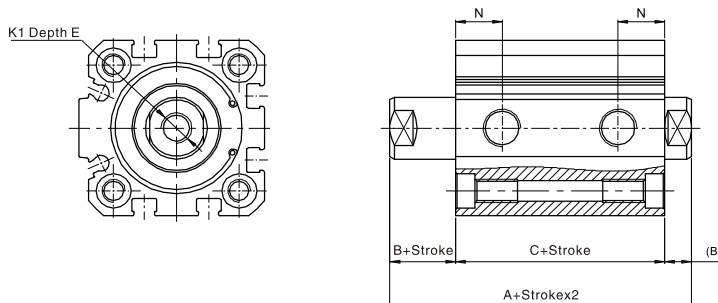

Bore/Sign	A	B	C	N	K1	E
32	58	7	44	12	M8X1.25	12
40	59	7	45	13	M8X1.25	12

#### Φ50~Φ100

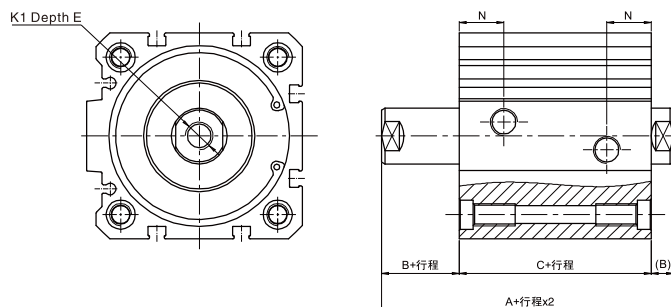

Bore/Sign	A	B	C	N	K1	E
50	61	8	45	13.5	M10X1.5	12(5 ≤ S < 15)/16(S ≥ 15)
63	65	8	49	16	M10X1.5	12(5 ≤ S < 15)/16(S ≥ 15)
80	74	10	54	16	M12X1.75	14(10 ≤ S < 25)/21(S ≥ 25)
100	87	10	67	20.5	M12X1.75	21

Note: Not marked dimension, the same as standard type. Parts of double shaft male thread type, please refer to standard dimension.

## Main Dimension

SFJ

Φ20、Φ25

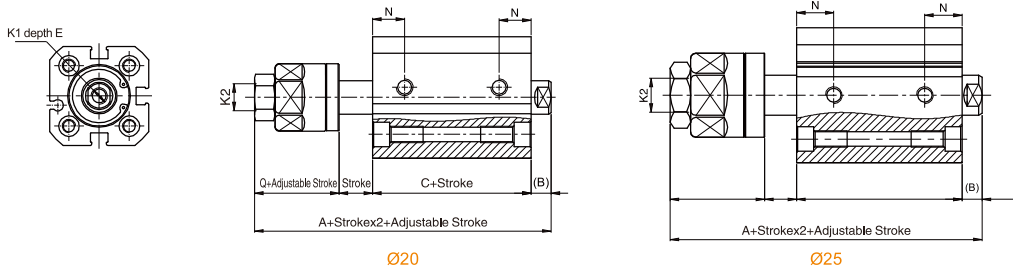

Bore/Sign	A	B	C	Q	N	K1	E	K2
20	68	6	37	25	9.5	M6X1.0	10	M8X1.25
25	72.5	6	39	28	11	M6X1.0	10	M10X1.25

Φ32、Φ40

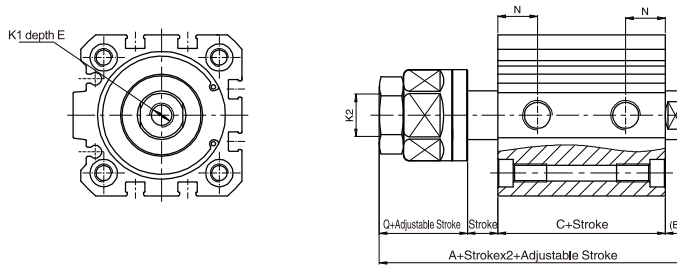

Bore/Sign	A	B	C	Q	N	K1	E	K2
32	79	7	44	30	12	M8X1.25	12	M14X1.5
40	81	7	45	29	13	M8X1.25	12	M14X1.5

Φ50~Φ100

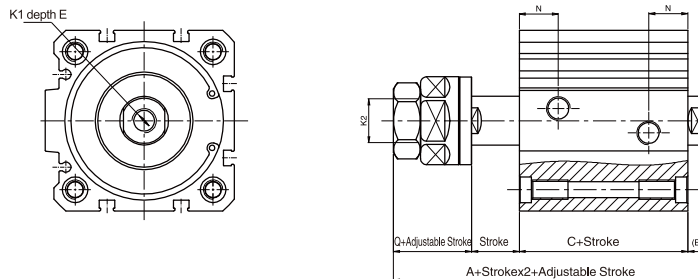

Bore/Sign	A	B	C	Q	N	K1	E	K2
50	85	8	45	32	13.5	M10X1.5	12(5≤S<15)/16(S≥15)	M18X1.5
63	88.5	8	49	32	16	M10X1.5	12(5≤S<15)/16(S≥15)	M18X1.5
80	101	10	54	37	16	M12X1.75	14(10≤S<25)/21(S≥25)	M22X1.5
100	113.5	10	67	37	20.5	M12X1.75	21	M26X1.5

Note: Not marked dimension, the same as standard type. Parts of double shaft male thread type, please refer to standard dimension.

# SF Series ISO21287 Compact Cylinder



## ◎ Main Dimension

### SFSB

#### Φ20、Φ25

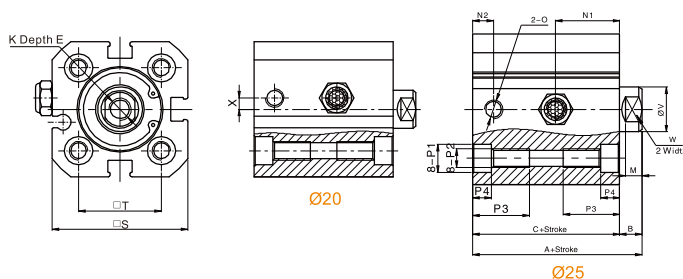

Bore/Sign	A	C	N1	N2	B	E	M	K	O	P1	P2	P3	P4	S	T	X	V	W
20	43	37	15	5.5	6	10	4	M6X1.0	M5X0.8	Φ7.3	M5X0.8	15	5	36	22	3	10	8
25	45	39	17	5.5	6	10	4.5	M6X1.0	M5X0.8	Φ7.3	M5X0.8	15	5	40	26	-	12	10

#### Φ32、Φ40

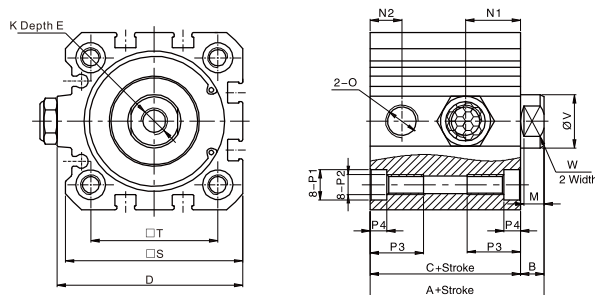

Bore/Sign	A	C	N1	N2	B	D	E	M	K	O	P1	P2	P3	P4	S	T	V	W
32	51	44	15	8	7	48	12	6	M8X1.25	1/8"	Φ9	M6X1.0	16	5	45.5	32.5	16	14
40	52	45	16.5	9.5	7	55.5	12	6	M8X1.25	1/8"	Φ9	M6X1.0	16	5	53	38	16	14

#### Φ50~Φ100

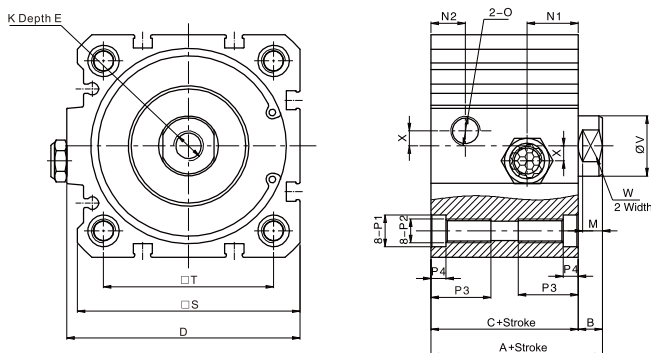

Bore/Sign	A	C	N1	N2	B	D	E	M	K	O	P1	P2	P3	P4	S	T	X	V	W
50	53	45	16	10.5	8	65.5	16	6.5	M10X1.5	1/8"	Φ10.5	M8X1.25	20	5	63	46.5	4	20	17
63	57	49	17	11.5	8	77.5	16	6.5	M10X1.5	1/8"	Φ10.5	M8X1.25	20	5	74	56.5	5	20	17

Note: With magnet and without magnet, the dimensions are same.

## ◎ Main Dimension

### SFSA

#### Φ20、Φ25

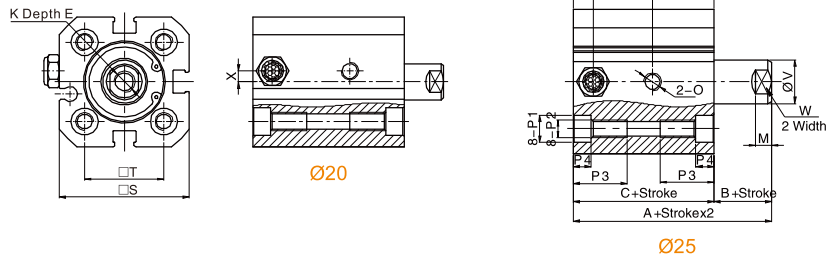

Bore/Sign	A	C	N1	N2	B	E	M	K	O	P1	P2	P3	P4	S	T	X	V	W
20	43	37	15	5.5	6	10	4	M6X1.0	M5X0.8	Φ 7.3	M5X0.8	15	5	36	22	3	10	8
25	45	39	12	5.5	6	10	4.5	M6X1.0	M5X0.8	Φ 7.3	M5X0.8	15	5	40	26	-	12	10

#### Φ32、Φ40

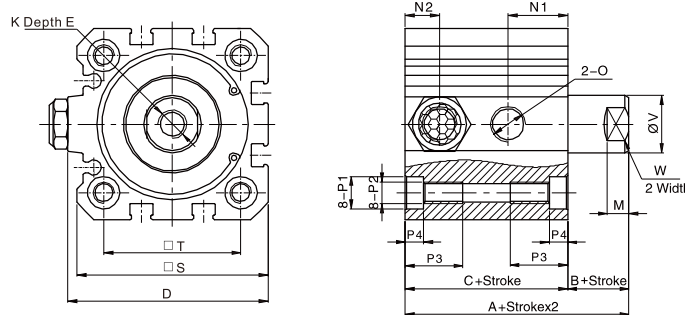

Bore/Sign	A	C	N1	N2	B	D	E	M	K	O	P1	P2	P3	P4	S	T	V	W
32	51	44	15	8	7	48	12	6	M8X1.25	1/8"	Φ9	M6X1.0	16	5	45.5	32.5	16	14
40	52	45	16.5	9.5	7	55.5	12	6	M8X1.25	1/8"	Φ9	M6X1.0	16	5	53	38	16	14

#### Φ50~Φ100

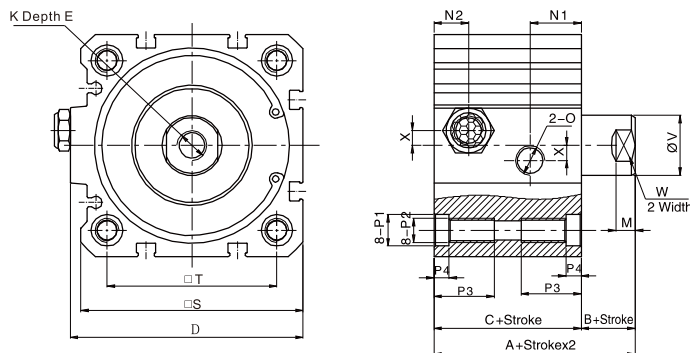

Bore/Sign	A	C	N1	N2	B	D	E	M	K	O	P1	P2	P3	P4	S	T	X	V	W
50	53	45	16	10.5	8	65.5	16	6.5	M10X1.5	1/8"	Φ 10.5	M8X1.25	20	5	63	46.5	4	20	17
63	57	49	17	11.5	8	77.5	16	6.5	M10X1.5	1/8"	Φ 10.5	M8X1.25	20	5	74	56.5	5	20	17

Note: With magnet and without magnet, the dimensions are same.

# SF Series ISO21287 Compact Cylinder



## Male Thread Dimension

SF, SFD, SFJ, SFSB

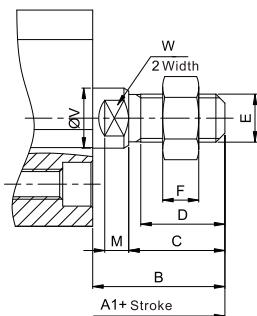

Bore/Sign	A1	B	C	D	E	F	M	V	W
20	59	22	16	14	M8X1.25	6	4	10	8
25	61	22	16	14	M8X1.25	6	4.5	12	10
32	70	26	19	16.5	M10X1.25	6	6	16	14
40	71	26	19	16.5	M10X1.25	6	6	16	14
50	75	30	22	19.5	M12X1.25	7	6.5	20	17
63	79	30	22	19.5	M12X1.25	7	6.5	20	17
80	92	38	28	25	M16X1.5	8	8.5	25	22
100	105	38	28	25	M16X1.5	8	8	32	27

Note: For SFSB cylinder,  $\Phi 80$  and  $\Phi 100$  are not optional.

SFSA型

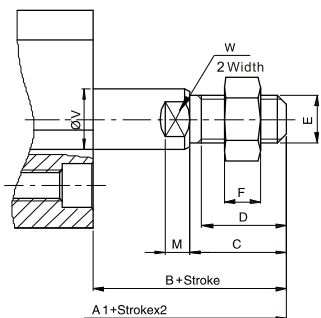

Bore/Sign	A1	B	C	D	E	F	M	V	W
20	59	22	16	14	M8X1.25	6	4	10	8
25	61	22	16	14	M8X1.25	6	4.5	12	10
32	70	26	19	16.5	M10X1.25	6	6	16	14
40	71	26	19	16.5	M10X1.25	6	6	16	14
50	75	30	22	19.5	M12X1.25	7	6.5	20	17
63	79	30	22	19.5	M12X1.25	7	6.5	20	17

## Installation Note

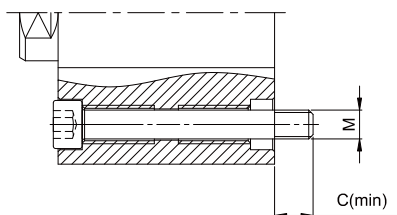

Bore/Sign	M	C
20	M4X0.7	6
25	M4X0.7	6
32	M5X0.8	7
40	M5X0.8	7
50	M6X1.0	9
63	M6X1.0	9
80	M8X1.25	12
100	M8X1.25	12

## SFM

### Guide Rod Type Cylinder

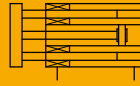

#### Specifications

Bore(mm)	20	25	32	40
Acting type	Double Acting			
Working medium	Clean Air(40 μm filtration)			
Working pressure(MPa)	0.1~1.0			
Garanteed pressure(MPa)	1.5			
Working temperature(°C)	-20~80(No freezing)			
Speed range(mm/s)	30~500			
Stroke tolerance(mm)	+1.0 0			
Cushion type	Rubber cushion			
Port size	M5X0.8		G1/8 ①	

① NPT、PT port size is optional.

#### How to Order?

Series	Bore	X	Stroke	Magnet	Thread Type
SFM	20 25 32 40		5 10 15 ...	Blank: No magnet S : With magnet	Blank: G P: PT T: NPT

#### Order Example:

SFM series basic cylinder, bore 25mm, stroke 20mm, with magnet, G thread, ERP code is: SFM25X20-S

#### Optional Accessories

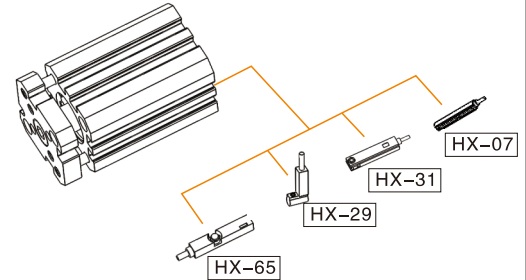

Note: Short stroke please use HX-29 series due to limited space.

#### Stroke

Bore (mm)	Standard Stroke (mm)														Max. Stroke (mm)				
Double Acting	20~40	5	10	15	20	25	30	35	40	45	50	55	60	70	75	80	90	100	100

#### Internal Structure

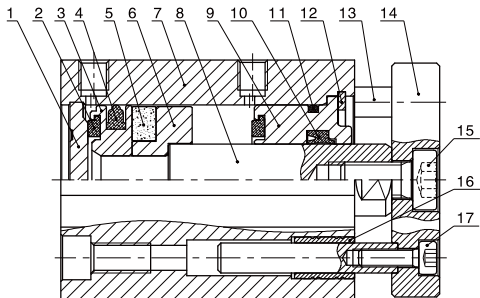

No.	Part Name	Material
1	Rear cover	Aluminum alloy
2	Anti-bump cushion	TPU
3	Piston	Aluminum alloy
4	Piston seal	NBR
5	Integrated magnet	RbFeB
6	Magnet seat	Aluminum alloy
7	Barrel	Aluminum alloy
8	Piston rod	Stainless steel/Carbon steel
9	Head cover	Aluminum alloy
10	Piston rod seal	TPU
11	O-ring	NBR
12	C type retainer ring	Spring steel
13	Guide	Stainless steel
14	Fixing plate	Aluminum alloy
15	Hexagon Socket Cap Head Screw	Carbon steel
16	Slide bearing	Brass
17	Hexagon Socket Cap Head Screw	Carbon steel

# SFM Series Compact Cylinder/Guide Rod Type



## ◎ Main Dimension

SFMΦ20、Φ25

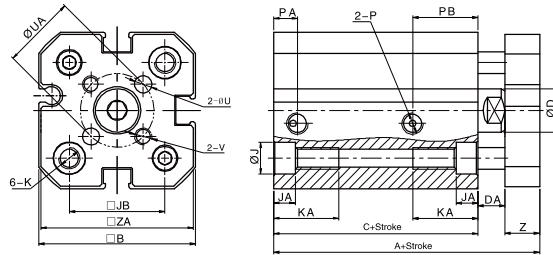

Bore/Sign	A	B	C	D	DA	J	JA	JB	K	KA	P	PA	PB	U	UA	V	Z	ZA
20	51	36	37	10	6	7.3	5	22	M5X0.8 Through holeΦ4.2	15	M5X0.8	5.5	15	4	17	M4X0.7	8	35
25	53	40	39	12	6	7.3	5	26	M5X0.8 Through holeΦ4.2	15	M5X0.8	5.5	17	5	22	M5X0.8	8	39

SFMΦ32、Φ40

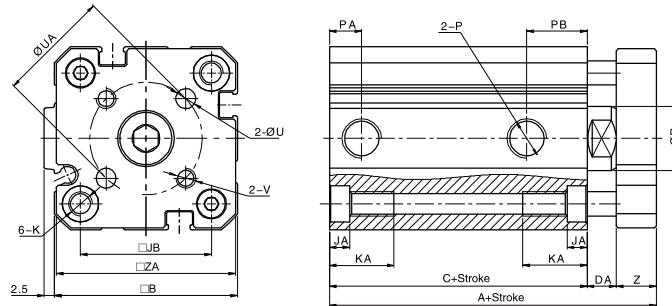

Bore/Sign	A	B	C	D	DA	J	JA	JB	K	KA	P	PA	PB	U	UA	V	Z	ZA
32	61	45.5	44	16	7	9	5	32.5	M6X1.0 Through holeΦ5.2	16	G1/8	8	15	5	28	M5X0.8	10	44.5
40	62.5	53	45	16	7.5	9	5	38	M6X1.0 Through holeΦ5.2	16	G1/8	9.5	16.5	5	33	M5X0.8	10	52

## SD

### Compact Cylinder

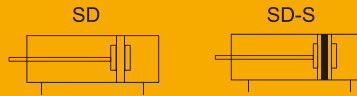

#### Specifications

Bore(mm)	12	16	20	25	32	40	50	63	80	100
Acting type	Double Acting									
Working medium	Clean Air(40 μm filtration)									
Working pressure(MPa)	0.1~1.0(Double acting) / 0.2~1.0(Single acting)									
Garanteed pressure(MPa)	1.5									
Working temperature(°C)	-20~80(No freezing)									
Speed range(mm/s)	30~500									
Cushion type	Rubber cushion									
Port size	M5 x 0.8			G1/8 ①			G1/4 ①		G3/8 ①	

① PT, NPT port size is optional.

#### How to Order?

Series No	Type No	Bore	X	Stroke	Adjustable Stroke	Magnet No	Piston Rod Thread Type	Thread Type
SD	Blank: Basic type	12		25	10	Blank: No magnet S: With magnet	Blank: Female thread M: Male thread	Blank: G P: PT T: NPT
	D: Double shaft type	16		50	20			
	J: Double shaft and adjustable stroke type	20		75	30			
		25		...	40			
	SA: Single acting spring extend	...			50			
	SB: Single acting spring return	100			75			
	T: Multi position type				100			
W: Double shaft and Multi position type								

#### Order Example:

SD Series single acting spring extend cylinder, 40mm bore, 30mm stroke, with magnet, femal thread on piston rod, G thread  
ERP code is: SDSA40X30-S

#### Optional Accessories

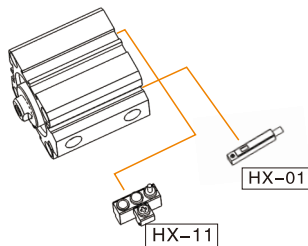

#### Stroke

Bore (mm)	Standard Stroke (mm)	Max. Stroke (mm)	
Double Acting	12/16	5 10 15 20 25 30 35 40 45 50	60
	20	5 10 15 20 25 30 35 40 45 50 55 60 65 70 75 80 85 90	150
	25	5 10 15 20 25 30 35 40 45 50 55 60 65 70 75 80 85 90 100 110 120	150
	32~100	5 10 15 20 25 30 35 40 45 50 55 60 65 70 75 80 85 90 100 110 120	200
Single Acting	12~63	5 10 15 20 25 30	30

Note:The dimensions of non-std stroke cylinder has the same dimensions as the next longer stroke std. stroke cylinder.  
e.g. 27mm stroke cylinder has the same dimensions of 30 std. stroke cylinder.

# SD Series Compact Cylinder



## Internal Structure

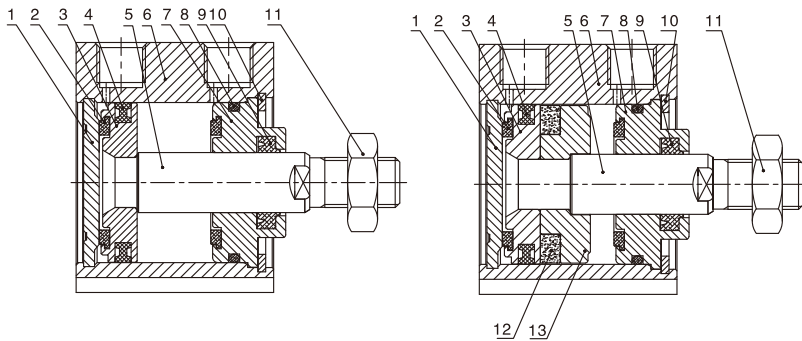

No	Part Name	Material
1	Rear cover	Aluminum alloy
2	Anti-bump cushion	Aluminum alloy
3	Piston	Aluminum alloy
4	Piston seal	S45C hard chrome carbon steel
5	Piston rod	Stainless Steel
6	Barrel	NBR
7	Head cover	NBR
8	O-ring	NBR
9	Piston rod seal	Composite material
10	C type retainer ring	RbFeb
11	Nut	Steel
12	Magnet	Carbon steel
13	Magnet base	Cu

## Main Dimension

SD  $\Phi 12-\Phi 16$

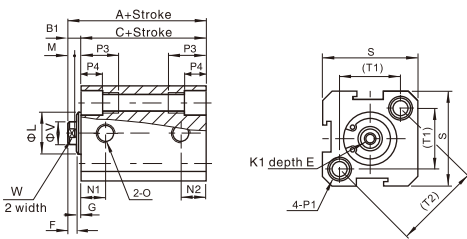

SD  $\Phi 20-\Phi 100$

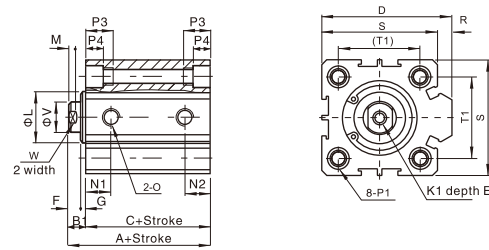

Sign Bore	A		C		B1	D	E	F	G	K1	L	M	N1		N2	O	P1					P3	P4	R	S	T1	T2	V	W							
	standard	With magnet	standard	With magnet									St=5	St>5			St=5	St>5	S=5	S>5	S=5									S>5						
12	22	32	17	27	5	-	6	4	1	M3X0.5	10.2	3	7.5	7.5	5	5	M5X0.8	Counter bore: $\Phi 6.5$ Thread: M5X0.8 Through Hole: $\Phi 4.2$	12	4.5	-	25	16.2	23	6	5										
16	24	34	18.5	28.5	5.5	-	6	4	1.5	M3X0.5	11	3	8	8	5	5.5	M5X0.8	Counter bore: $\Phi 6.5$ Thread: M5X0.8 Through Hole: $\Phi 4.2$	12	4.5	-	29	19.8	28	6	5										
20	25	35	19.5	29.5	5.5	36	8	4	1.5	M4x0.7	13	3	8.2	9	5	5.5	M5X0.8	Counter bore: $\Phi 6.5$ Thread: M5X0.8 Through Hole: $\Phi 4.2$	14	4.5	2	34	24	-	8	6										
25	27	37	21	31	6	42	10	4	2	M5X0.8	17	3	9	9	5.5	5.5	M5X0.8	Counter bore: $\Phi 6.2$ Thread: M6X1.0 Through Hole: $\Phi 5.2$	15	5.5	2	40	28	-	10	8										
32	31.5	41.5	24.5	34.5	7	50	12	4.5	2.5	M6X1.0	22	3	9	9	6.5	9	1/8"	Counter bore: $\Phi 8.2$ Thread: M6X1.0 Through Hole: $\Phi 5.2$	16	5.5	6	44	34	-	12	10										
40	33	43	26	36	7	58.5	12	4	3	M8X1.25	28	3	9.5	9.5	7.5	7.5	1/8"	Counter bore: $\Phi 10.2$ Thread: M8X1.25 Through Hole: $\Phi 6.8$	20	7.5	6.5	52	40	-	16	14										
50	37	47	28	38	9	71.5	15	5	4	M10X1.5	38	3	8	10.5	8	10.5	1/4"	Counter bore: $\Phi 11$ Thread: M8X1.25 Through Hole: $\Phi 6.8$	25	8.5	9.5	62	48	-	20	17										
63	41	51	32	42	9	84.5	15	5	4	M10X1.5	40	3	9.5	12	9.5	11	1/4"	Counter bore: $\Phi 11$ Thread: M8X1.25 Through Hole: $\Phi 6.8$	25	8.5	9.5	75	60	-	20	17										
80	52	62	41	51	11	104	20	6	5	M14X1.5	45	4	11.5	14.5	11.5	14.5	3/8"	Counter bore: $\Phi 14$ Thread: M12X1.75 Through Hole: $\Phi 9.2$	25	10.5	10	94	74	-	25	22										
100	63	73	51	61	12	124	20	7	5	M18X1.5	55	4	16	20.5	16	20.5	3/8"	Counter bore: $\Phi 17.5$ Thread: M14X2.0 Through Hole: $\Phi 11.3$	30	13	10	114	90	-	32	27										

SDW  $\Phi 12-\Phi 16$

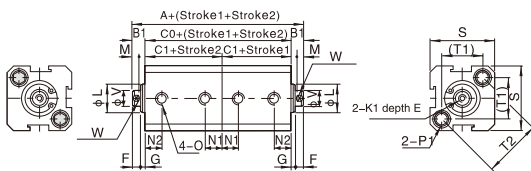

SDW  $\Phi 20-\Phi 100$

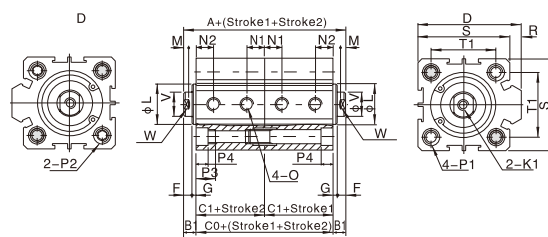

Bore/Sign	Basic Type			With Magnet			B1	D	E	F	G	K1	L	M	N2		N1		P3	P4	R	S	T1	T2	V					
	A	C0	C1	A	C0	C1									S=5	S>5	S=5	S>5												
12	44	34	17	64	54	27	5	-	6	4	1	M3x0.5	10.2	3	7.5	7.5	5	5												
16	48	37	18.5	68	57	28.5	5.5	-	6	4	1.5	M3x0.5	11	3	8	8	5	5.5												
20	50	39	19.5	70	59	29.5	5.5	36	8	4	1.5	M4x0.7	13	3	8.2	9	5	5.5												
25	54	42	21	74	62	31	6	42	10	4	2	M5x0.8	17	3	9	9	5.5	5.5												
32	63	49	24.5	83	69	34.5	7	50	12	4.5	2.5	M6x1	22	3	9	9	6.5	9												
40	66	52	26	86	72	36	7	58.5	12	4	3	M8x1.25	28	3	9.5	9.5	7.5	7.5												
50	74	56	28	94	76	38	9	71.5	15	5	4	M10x1.5	38	3	8	10.5	8	10.5												
63	82	64	32	102	84	42	9	84.5	15	5	4	M10x1.5	40	3	9.5	12	9.5	11												
80	104	82	41	124	102	51	11	104	20	6	5	M14x1.5	45	4	11.5	14.5	14.5	14.5												
100	126	102	51	146	122	61	12	124	20	7	5	M18x1.5	55	4	20.5	20.5	20.5	20.5												

Bore/Sign	O	W	P1					P2					P3	P4	R	S	T1	T2	V												
			$\Phi 6.5$ Thread: M5X0.8 Through Hole: $\Phi 4.2$	$\Phi 6.5$ Thread: M5X0.8 Through Hole: $\Phi 4.2$	Counter bore: $\Phi 6.5$ Thread: M5X0.8 Through Hole: $\Phi 4.2$	Counter bore: $\Phi 6.2$ Thread: M6X1.0 Through Hole: $\Phi 5.2$	Counter bore: $\Phi 8.2$ Thread: M6X1.0 Through Hole: $\Phi 5.2$	Counter bore: $\Phi 10.2$ Thread: M8X1.25 Through Hole: $\Phi 6.8$	Counter bore: $\Phi 11$ Thread: M8X1.25 Through Hole: $\Phi 6.8$	Counter bore: $\Phi 11$ Thread: M8X1.25 Through Hole: $\Phi 6.8$	Counter bore: $\Phi 14$ Thread: M12X1.75 Through Hole: $\Phi 9.2$	Counter bore: $\Phi 17.5$ Thread: M14X2.0 Through Hole: $\Phi 11.3$								Counter bore: $\Phi 6.5$ Through Hole: $\Phi 5.2$	Counter bore: $\Phi 8.2$ Through Hole: $\Phi 6.2$	Counter bore: $\Phi 10$ Through Hole: $\Phi 8.2$	Counter bore: $\Phi 11$ Through Hole: $\Phi 8.5$	Counter bore: $\Phi 11$ Through Hole: $\Phi 8.5$	Counter bore: $\Phi 14$ Through Hole: $\Phi 12.3$	Counter bore: $\Phi 17.5$ Through Hole: $\Phi 14.2$					
12	M5x0.8	5																													
16	M5x0.8	5																													
20	M5x0.8	6																													
25	M5x0.8	8																													
32	1/8"	10																													
40	1/8"	14																													
50	1/4"	17																													
63	1/4"	17																													
80	3/8"	22																													
100	3/8"	27																													

# SD Series Compact Cylinder



## Main Dimension

### SDD $\Phi 12$ - $\Phi 100$

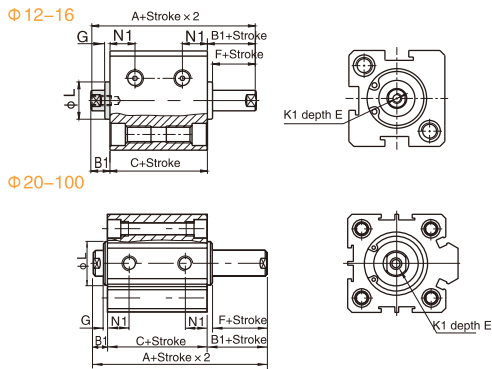

Bore	Basic Type		With Magnet		E		B1	F	G	K1	L	N1	
	A	C	A	C	S $\leq 10$	S > 10						S=5	S > 5
12	27	17	37	27	6		5	4	1	M3x0.5	10.2	5.5	6.3
16	29.5	18.5	39.5	28.5	6		5.5	4	1.5	M3x0.5	11	6	7.3
20	30.5	19.5	40.5	29.5	8		5.5	4	1.5	M4x0.7	15	6.5	7.5
25	33	21	43	31	10		6	4	2	M5x0.8	17	7	8
32	38.5	24.5	48.5	34.5	12	12	7	4	3	M6x1	22	6	9
40	40	26	50	36	12	12	7	4	3	M8x1.25	28	8	10
50	46	28	56	38	15(S $\leq 10, 11$ )	15	9	5	4	M10x1.5	38	8	10.5
63	50	32	60	42	15(S $\leq 10, 11$ )	15	9	5	4	M10x1.5	40	9.5	11.8
80	63	41	73	51	13	20	11	6	5	M14x1.5	45	14.5	14.5
100	75	51	85	61	18	20	12	7	5	M18x1.5	55	20.5	20.5

### SDJ $\Phi 12$ - $\Phi 100$

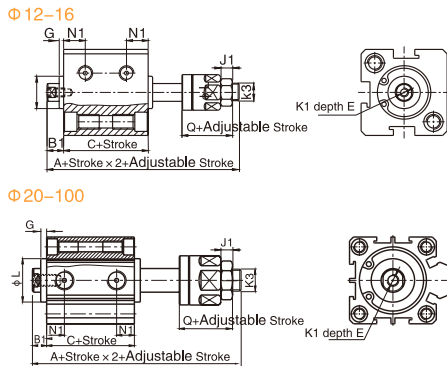

Bore	Basic Type		With Magnet		E		B1	Q	G	J1	K1	K3	L	N1	
	A	C	A	C	S $\leq 10$	S > 10								S=5	S > 5
12	40	17	50	27	6		5	17	1	4	M3x0.5	M5x0.8	10.2	5.5	6.3
16	42.5	18.5	52.5	28.5	6		5.5	17	1.5	4	M3x0.5	M5x0.8	11	6	7.3
20	47.5	19.5	57.5	29.5	8		5.5	21	1.5	5	M4x0.7	M6x1.0	15	6.5	7.5
25	54	21	64	31	10		6	25	2	6	M5x0.8	M8x1.25	17	7	8
32	61.5	24.5	71.5	34.5	12	12	7	27	3	6	M6x1.0	M10x1.25	22	6	9
40	65	26	75	36	12	12	7	29	3	8	M8x1.25	M14x1.5	28	8	10
50	73	28	83	38	15(S $\leq 10, 11$ )	15	9	32	4	11	M10x1.5	M18x1.5	38	8	10.5
63	77	32	87	42	15(S $\leq 10, 11$ )	15	9	32	4	11	M10x1.5	M18x1.5	40	9.5	11.8
80	94	41	104	51	13	20	11	37	5	13	M14x1.5	M22x1.5	45	14.5	14.5
100	105	51	115	61	18	20	12	37	5	13	M18x1.5	M26x1.5	55	20.5	20.5

### SDT $\Phi 12$ - $\Phi 100$

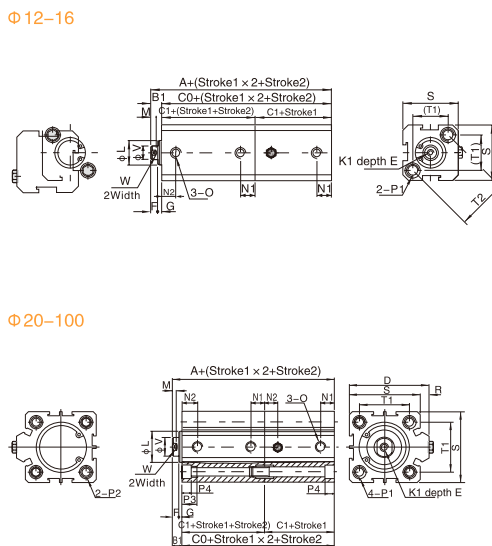

Bore	Basic Type			With Magnet			B1	D	E	F	G	K1	L	M	N1		N2	
	A	C0	C1	A	C0	C1									S=5	S > 5	S=5	S > 5
12	39	34	17	59	54	27	5	-	6	4	1	M3 x 0.5	10.2	3	5	5	7.5	7.5
16	42.5	37	18.5	62.5	57	28.5	5.5	-	6	4	1.5	M3 x 0.5	10	3	5	5.5	8	8
20	44.5	39	19.5	64.5	59	29.5	5.5	36	8	4	1.5	M4 x 0.7	13	3	5	5.5	8.2	9
25	48	42	21	68	62	31	6	42	10	4	2	M5 x 0.8	17	3	5.5	5.5	9	9
32	56	49	24.5	76	69	34.5	7	50	12	4	2.4	M6 x 1	22	3	6.5	9	9	9
40	59	52	26	79	72	36	7	58.5	12	4	3	M8 x 1.25	28	3	7.5	7.5	9.5	9.5
50	65	56	28	85	76	38	9	71.5	15	5	4	M10 x 1.5	38	3	8	10.5	8	10.5
63	73	64	32	93	84	42	9	84.5	15	5	4	M10 x 1.5	40	3	9.5	11	9.5	12
80	93	82	41	113	102	51	11	104	20	6	5	M14 x 1.5	45	4	14.5	14.5	14.5	14.5
100	114	102	51	134	122	61	12	124	20	7	5	M18 x 1.5	55	4	20.5	20.5	20.5	20.5
Bore	O	W	P1			P2		P3	P4	R	S	T1	T2	V				
12	M5x0.8	5	$\Phi 6.5$ Thread: M5X0.8 Through Hole: $\Phi 4.2$			-		12	4.5	-	25	16.2	23	6				
16	M5x0.8	5	$\Phi 6.5$ Thread: M5X0.8 Through Hole: $\Phi 4.2$			-		12	4.5	-	29	19.8	28	6				
20	M5x0.8	6	Counter bore: $\Phi 6.5$ Thread: M5X0.8 Through Hole: $\Phi 4.2$			Counter bore: $\Phi 6.5$ Through Hole: $\Phi 5.2$		14	4.5	2	34	24	-	8				
25	M5x0.8	8	Counter bore: $\Phi 6.2$ Thread: M6X1.0 Through Hole: $\Phi 4.6$			Counter bore: $\Phi 8.2$ Through Hole: $\Phi 6.2$		15	5.5	2	40	28	-	10				
32	1/8"	10	Counter bore: $\Phi 6.2$ Thread: M6X1.0 Through Hole: $\Phi 4.6$			Counter bore: $\Phi 8.2$ Through Hole: $\Phi 6.2$		16	5.5	6	44	34	-	12				
40	1/8"	14	Counter bore: $\Phi 11$ Thread: M8X1.25 Through Hole: $\Phi 6.5$			Counter bore: $\Phi 10$ Through Hole: $\Phi 8.2$		20	7.5	6.5	52	40	-	16				
50	1/4"	17	Counter bore: $\Phi 11$ Thread: M8X1.25 Through Hole: $\Phi 6.5$			Counter bore: $\Phi 11$ Through Hole: $\Phi 8.5$		25	8.5	9.5	62	48	-	20				
63	1/4"	17	Counter bore: $\Phi 11$ Thread: M8X1.25 Through Hole: $\Phi 6.5$			Counter bore: $\Phi 11$ Through Hole: $\Phi 8.5$		25	8.5	9.5	75	60	-	20				
80	3/8"	22	Counter bore: $\Phi 14$ Thread: M12X1.75 Through Hole: $\Phi 9.2$			Counter bore: $\Phi 14$ Through Hole: $\Phi 12.3$		25	10.5	10	94	74	-	25				
100	3/8"	27	Counter bore: $\Phi 17.5$ Thread: M14X2 Through Hole: $\Phi 11.3$			Counter bore: $\Phi 17.5$ Through Hole: $\Phi 14.2$		30	13	10	114	90	-	32				

# SD Series Compact Cylinder



## Main Dimension

SDSB/SDSA  $\Phi 12$ - $\Phi 63$

SDSB  
 $\Phi 12, \Phi 16$

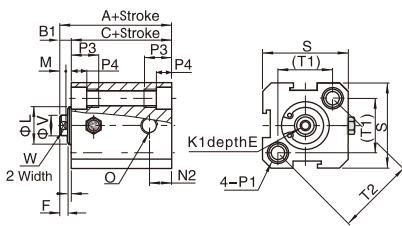

SDSB  
 $\Phi 20$ - $\Phi 63$

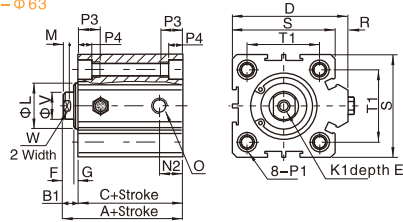

SDSA  
 $\Phi 12, \Phi 16$

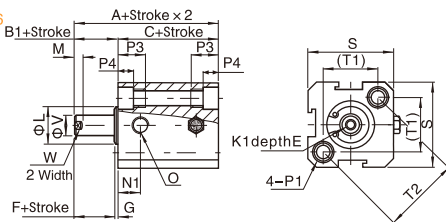

SDSA  
 $\Phi 20$ - $\Phi 63$

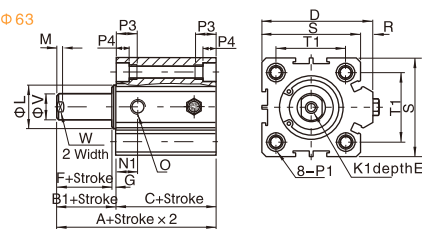

Sign	A (standard)		A (With magnet)		C (standard)		C (With magnet)		B1	D	E	F	G	K1	L	M	N1	N2
	St≤10	St>10	St≤10	St>10	St≤10	St>10	St≤10	St>10										
12	32	42	42	52	27	37	37	47	5	-	6	4	1	M3 x 0.5	10.2	3	7.5	5
16	34	44	44	54	28.5	38.5	38.5	48.5	5.5	-	6	4	1.5	M3 x 0.5	11	3	8	5.5
20	35	45	45	55	29.5	39.5	39.5	49.5	5.5	36	8	4	1.5	M4 x 0.7	13	3	9	5.5
25	37	47	47	57	31	41	41	51	6	42	10	4	2	M5 x 0.8	17	3	9	5.5
32	41.5	51.5	51.5	61.5	34.5	44.5	44.5	54.5	7	50	12	4.5	2.5	M6 x 1.0	22	3	9	9
40	43	53	53	63	36	46	46	56	7	58.5	12	4	3	M8 x 1.25	28	3	9.5	7.5
50	47	57	57	67	38	48	48	58	9	71.5	15	5	4	M10 x 1.5	38	3	10.5	10.5
63	51	61	61	71	42	52	52	62	9	84.5	15	5	4	M10 x 1.5	40	3	12	11

Bore / Sign	O	R	S	T1	T2	P1	P3	P4	V	W
12	M5 x 0.8	-	25	16.2	23	Counter bore: $\Phi 6.5$ Thread: M5 x 0.8 Through Hole: $\Phi 4.2$	12	4.5	6	5
16	M5 x 0.8	-	29	19.8	28	Counter bore: $\Phi 6.5$ Thread: M5 x 0.8 Through Hole: $\Phi 4.2$	12	4.5	6	5
20	M5 x 0.8	2	34	24	-	Counter bore: $\Phi 6.5$ Thread: M5 x 0.8 Through Hole: $\Phi 4.2$	14	4.5	8	6
25	M5 x 0.8	2	40	28	-	Counter bore: $\Phi 8.2$ Thread: M6 x 1.0 Through Hole: $\Phi 5.2$	15	5.5	10	8
32	1/8"	6	44	34	-	Counter bore: $\Phi 8.2$ Thread: M6 x 1.0 Through Hole: $\Phi 5.2$	16	5.5	12	10
40	1/8"	6.5	52	40	-	Counter bore: $\Phi 10.2$ Thread: M8 x 1.25 Through Hole: $\Phi 6.8$	20	7.5	16	14
50	1/8"	9.5	62	48	-	Counter bore: $\Phi 11$ Thread: M8 x 1.25 Through Hole: $\Phi 6.8$	25	8.5	20	17
63	1/4"	9.5	75	60	-	Counter bore: $\Phi 11$ Thread: M8 x 1.25 Through Hole: $\Phi 6.8$	25	8.5	20	17

## Male Thread Dimension

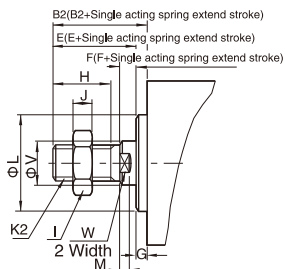

Bore / Sign	B2	E	F	G	H	I
12	17	16	4	1	10	8
16	17.5	16	4	1.5	10	8
20	20.5	19	4	1.5	13	10
25	23	21	4	2	15	12
32	25	22.5	4.5	2.5	15	17
40	35	32	4	3	25	19
50	37	33	5	4	25	27
63	37	33	5	4	25	27
80	44	39	6	5	30	32
100	50	45	7	5	35	36
Bore / Sign	J	K2	L	M	V	W
12	4	M5 x 0.8	10.2	3	6	5
16	4	M5 x 0.8	11	3	6	5
20	5	M6 x 1.0	13	3	8	6
25	6	M8 x 1.25	17	3	10	8
32	6	M10 x 1.25	22	3	12	10
40	8	M14 x 1.5	28	3	16	14
50	11	M18 x 1.5	38	3	20	17
63	11	M18 x 1.5	40	3	20	17
80	13	M22 x 1.5	45	4	25	22
100	13	M26 x 1.5	55	4	32	27

## SQ

### Compact Cylinder

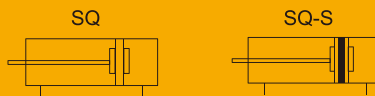

### Specifications

Bore(mm)	12	16	20	25	32	40	50	63	80	100
Acting type	Double Acting/Single Acting									
Working medium	Clean Air(40 μm filtration)									
Working pressure(MPa)	0.1~1.0(Double acting) / 0.2~1.0(Single acting)									
Garanteed pressure(MPa)	1.5									
Working temperature(°C)	-20~80(No freezing)									
Speed range(mm/s)	30~500									
Cushion type	Rubber cushion									
Port size	M5 x 0.8			G1/8 ①			G1/4 ①		G3/8 ①	

① PT、NPT port size is optional.

### How to Order?

Series No	Mounting type	Type No	Bore X	Stroke	Adjustable Stroke	Magnet No	Piston Rod Thread Type	Thread Type
SQ	Blank: Through hole A: Femal thread at both ends	Blank: Basic type D: Double shaft type J: Double shaft and adjustable stroke type SA: Single acting spring extend SB: Single acting spring return	12 16 20 25 ...	25 50 75 ...	10 20 30 40 50 75 100	Blank: No magnet S: With magnet	Blank: Female thread M: Male thread	Blank: G P: PT T: NPT

#### Order Example:

SQ Series single acting spring extend cylinder, through hole mounting type, 40mm bore, 30mm stroke, with magnet, femal thread on piston rod, G thread.  
ERP code is: SQSA40X30-S

### Optional Accessories

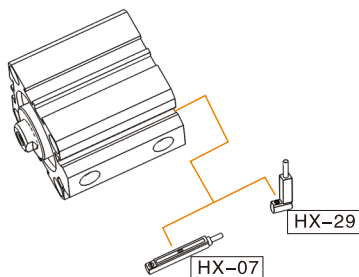

Note: Short stroke please use HX-29 series due to limited space.

### Stroke

	Bore (mm)	Standard Stroke (mm)	Max. Stroke (mm)
	Double Acting	12/16	5 10 15 20 25 30 35 40 45 50
20/25		5 10 15 20 25 30 35 40 45 50 60 70 75 80 90 100	150
32~100		5 10 15 20 25 30 35 40 45 50 60 70 75 80 90 100	100
Single Acting	12/16	5 10 15 20	20
	20~63	5 10 15 20 25 30	30

### Internal Structure

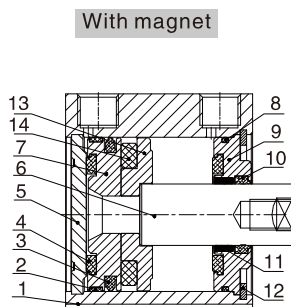
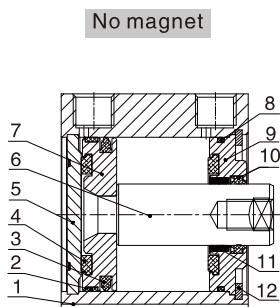

No	Part Name
1	Barrel
2	Wear ring
3	Piston seal
4	Anti-bump cushion
5	Rear cover
6	Piston rod
7	Piston
8	O-ring
9	Head cover
10	Piston rod seal
11	Self lubricating bearing
12	C type retainer ring
13	Magnet
14	Magnet base

# SQ Series Compact Cylinder



## Main Dimension

SQ  $\Phi 12-\Phi 25$  ( No magnet )

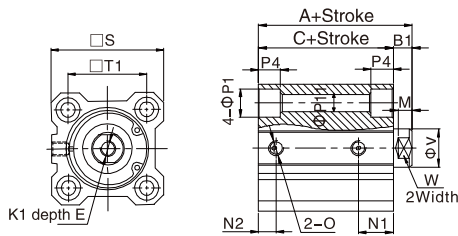

Through hole type

Thread type

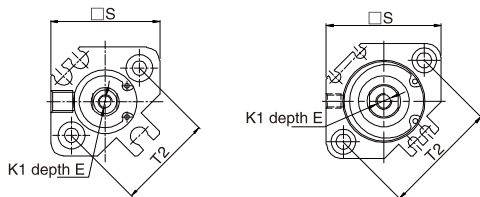

$\Phi 12$  ( With magnet )

$\Phi 16-\Phi 25$  (With magnet )

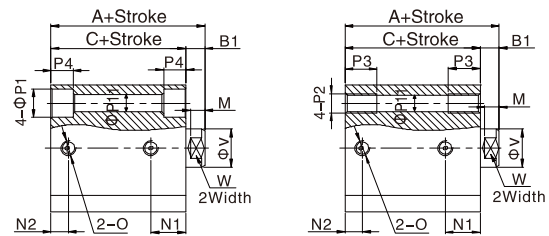

Through hole type

Thread type

Model	Basic Type						With Magnet							
	A		C		N1	N2	A	C	N1	N2	B1	D	E	M
	St≤50	St>60	St≤50	St>60										
12	20.5	-	17	-	7.5	5	31.5	28	9	5	3.5	-	6	3.5
16	22	-	18.5	-	8	5.5	34	30.5	9.5	5.5	3.5	-	8	3
20	24	34	19.5	29.5	9	5.5	36	31.5	9.5	5.5	4.5	-	7	4
25	27.5	37.5	22.5	32.5	11	5.5	37.5	32.5	11	5.5	5	-	12	4.5
Bore / Sign	K1	O	P1	P11	P2		P3	P4	S	T1	T2	V	W	
12	M3x0.5	M5x0.8	6.3	3.4	M4x0.7		7	3.5	25	15.5	22	6	5	
16	M4x0.7	M5x0.8	6.5	3.4	M4x0.7		7	3.5	29	20	28	8	6	
20	M5x0.8	M5x0.8	9	5.4	M6x1.0		10	7	36	25.5	36	10	8	
25	M6x1.0	M5x0.8	9	5.4	M6x1.0		10	7	40	28	40	12	10	

SQ  $\Phi 32-\Phi 100$

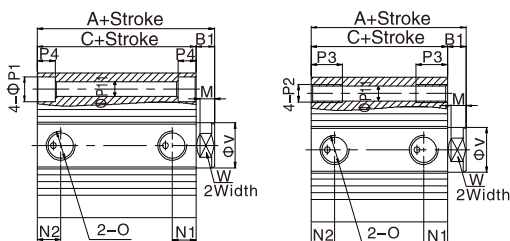

Through hole type

Thread type

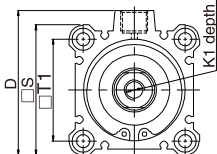

Model	Basic Type						With Magnet							
	A		C		N1	N2	A	C	N1	N2	B1	D	E	M
	St=5	St>5	St≤50	St>60										
32	30	40	23	33	7.5	6.5	40	33	10.5	7.5	7	49.5	13	6
40	36.5	46.5	29.5	39.5	11	8	46.5	39.5	11	8	7	57	13	6
50	38.5	48.5	30.5	40.5	9	9	48.5	40.5	10.5	10.5	8	71	15	6.5
63	44	54	36	46	14	9.5	54	46	15	10.5	8	84	15	6.5
80	53.5	63.5	43.5	53.5	16	14	63.5	53.5	16	14	10	104	20	8.5
100	65	75	53	63	20	17.5	75	63	20	17.5	12	123.5	26	9.5
Bore / Sign	K1	O	P1	P11	P2		P3	P4	S	T1	T2	V	W	
32	M8x1.25	1/8"	9	5.4	M6x1.0		10	7	45	34	-	16	14	
40	M8x1.25	1/8"	9	5.4	M6x1.0		10	7	52	40	-	16	14	
50	M10x1.5	1/4"	11	6.5	M8x1.25		14	8	64	50	-	20	17	
63	M10x1.5	1/4"	14	8.9	M10x1.5		18	10.5	77	60	-	20	17	
80	M16x2.0	3/8"	17.5	10.9	M12x1.75		22	13.5	98	77	-	25	22	
100	M20x2.5	3/8"	17.5	10.9	M12x1.75		22	13.5	117	94	-	32	27	

## Main Dimension

SQSA  $\Phi 12-\Phi 25$  ( No magnet )

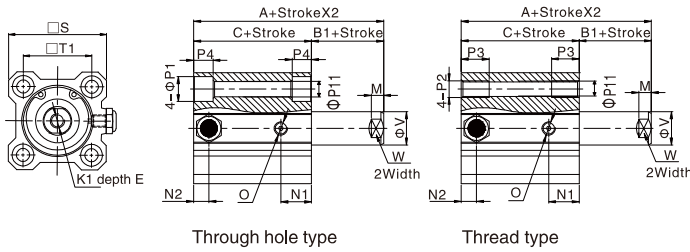

SQSB  $\Phi 12-\Phi 25$  ( No magnet )

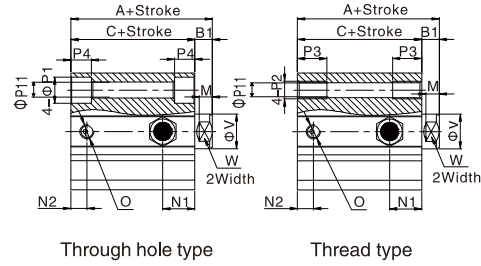

SQSA  $\Phi 12-\Phi 25$  ( With magnet )

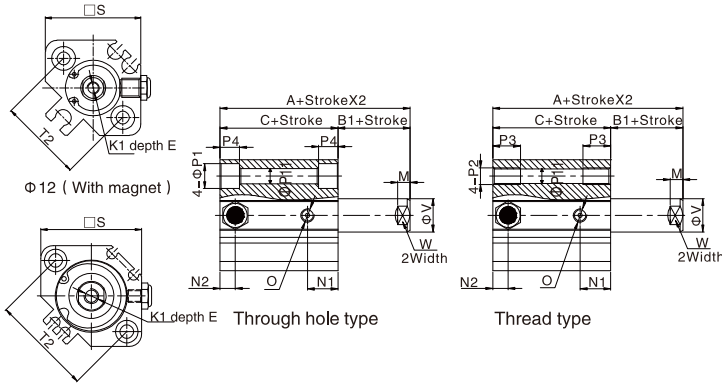

SQSB  $\Phi 12-\Phi 25$  ( With magnet )

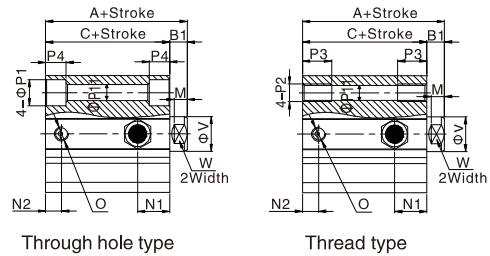

SQSA  $\Phi 32-\Phi 63$

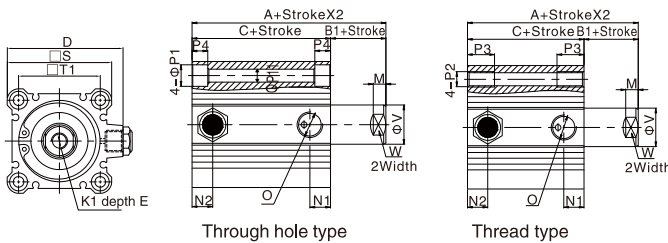

SQSB  $\Phi 32-\Phi 63$

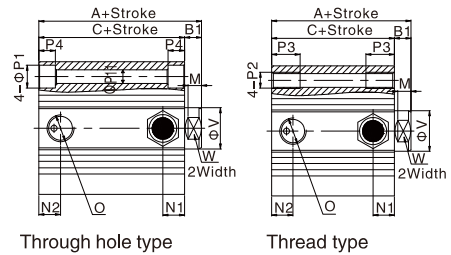

Model	Basic Type										
	A			C			N1	N2	B1	D	E
Bore /Sign	5/10	15/20	25/30	5/10	15/20	25/30					
Stroke	5/10	15/20	25/30	5/10	15/20	25/30	N1	N2	B1	D	E
12	25	30.5	-	22	27	-	7.5	5	3.5	-	6
16	27	32	-	23.5	28.5	-	8	5.5	3.5	-	8
20	29	34	39	24.5	29.5	34.5	9	5.5	4.5	-	7
25	32.5	37.5	42.5	27.5	32.5	37.5	11	5.5	5	-	12
32	35	40	45	28	33	38	10.5	7.5	7	49.5	13
40	41.5	46.5	51.5	34.5	39.5	44.5	11	8	7	57	13
50	48.5	53.5	58.5	40.5	45.5	50.5	10.5	10.5	8	71	15
63	54	59	64	46	51	56	15	10.5	8	84	15
Bore /Sign	O	P1	P11	P2	P3	P4					
12	M5x0.8	6.3	3.4	M4x0.7	7	3.5					
16	M5x0.8	6.5	3.4	M4x0.7	7	3.5					
20	M5x0.8	9	5.4	M6x1.0	10	7					
25	M5x0.8	9	5.4	M6x1.0	10	7					
32	1/8"	9	6.5	M6x1.0	10	7					
40	1/8"	9	8.9	M6x1.0	10	7					
50	1/4"	11	10.9	M8x1.25	14	8					
63	1/4"	14	10.9	M10x1.5	18	10.5					

Model	Basic Type									
	A			C			N1	N2	K1	
Bore /Sign	5/10	15/20	25/30	5/10	15/20	25/30				
Stroke	5/10	15/20	25/30	5/10	15/20	25/30	N1	N2	K1	
12	36.5	41.5	-	33	38	-	9	5	M3x0.5	
16	39	44	-	35.5	40.5	-	9.5	5.5	M4x0.7	
20	41	46	51	36.5	41.5	46.5	9.5	5.5	M5x0.8	
25	42.5	47.5	52.5	37.5	42.5	47.5	11	5.5	M6x1.0	
32	45	50	55	38	43	48	10.5	7.5	M8x1.25	
40	51.5	56.5	61.5	44.5	49.5	54.5	11	8	M8x1.25	
50	58.5	63.5	68.5	50.5	55.5	60.5	10.5	10.5	M10x1.5	
63	64	69	74	56	61	66	15	10.5	M10x1.5	
Bore /Sign	M	S	T1	T2	V	W				
12	3.5	25	15.5	22	6	5				
16	3	29	20	28	8	6				
20	4	36	25.5	36	10	8				
25	4.5	40	28	40	12	10				
32	6	45	34	-	16	14				
40	6	52	40	-	16	14				
50	6.5	64	50	-	20	17				
63	6.5	77	60	-	20	17				

# SQ Series Compact Cylinder



## Main Dimension

### SQD $\Phi 12-\Phi 25$ (No magnet)

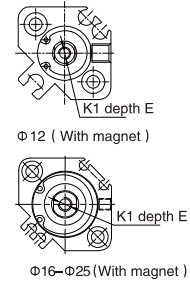
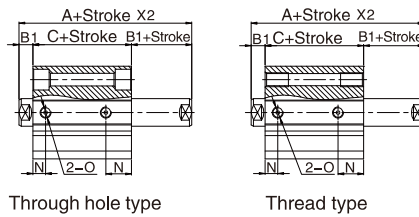
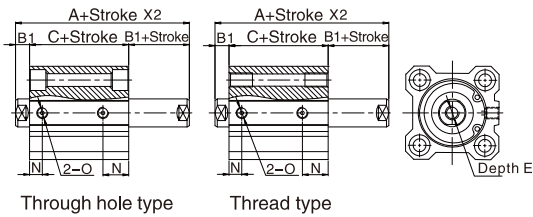

### SQD $\Phi 32-\Phi 63$

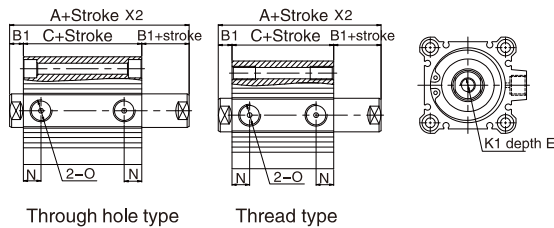

Bore /Sign	A		C		B1	E	N
	Standard	With magnet	Standard	With magnet			
12	32.2	39.4	25.2	32.4	3.5	6	9
16	33	43	26	36	3.5	8	9.5
20	35	47	26	38	4.5	7	9.5
25	39	49	29	39	5	9.5(St=5)/12(St>5)	11
32	44.5	54.5	30.5	40.5	7	9(St≤10)/13(St>10)	10
40	54	64	40	50	7	11(St≤10)/13(St>10)	13
50	56.5	66.5	40.5	50.5	8	12(St≤10)/15(St>10)	13.5
63	58	68	42	52	8	12(St≤10)/15(St>10)	16
80	71	81	51	61	10	14(St≤15)/20(St>15)	16
100	84.5	94.5	60.5	70.5	12	20(St≤25)/26(St>25)	21

Note: Not marked dimensions is same as standard type. Male thread type pls check this page.

### SQJ $\Phi 12-\Phi 25$ (No magnet)

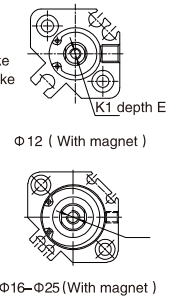
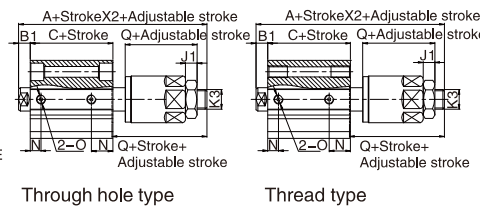
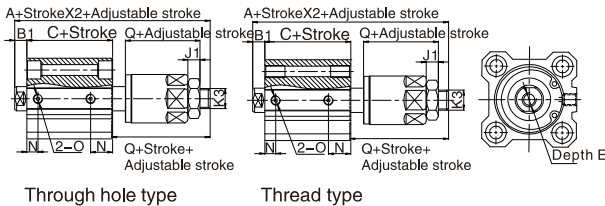

### SQJ $\Phi 32-\Phi 100$

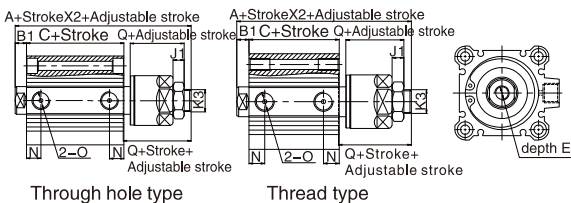

Bore /Sign	A		C		B1	E	N	Q	J1	K3
	Standard	With magnet	Standard	With magnet						
12	45.2	52.4	25.2	32.4	3.5	6	9	17	4	M5x0.8
16	50	60	26	36	3.5	8	9.5	21	5	M6x1.0
20	55	67	26	38	4.5	7	9.5	25	6	M8x1.25
25	61.5	71.5	29	39	5	9.5(St=5)/12(St>5)	11	28	6	M10x1.25
32	67	77	30.5	40.5	7	9(St≤10)/13(St>10)	10	30	8	M14x1.5
40	75.5	85.5	40	50	7	11(St≤10)/13(St>10)	13	29	8	M14x1.5
50	80.5	90.5	40.5	50.5	8	12(St≤10)/15(St>10)	13.5	32	11	M18x1.5
63	82	92	42	52	8	12(St≤10)/15(St>10)	16	32	11	M18x1.5
80	97.3	107.3	51	61	10	14(St≤15)/20(St>15)	16	37	13	M22x1.5
100	106.5	116.5	60.5	70.5	12	20(St≤25)/26(St>25)	20	37	13	M26x1.5

### Male type dimension

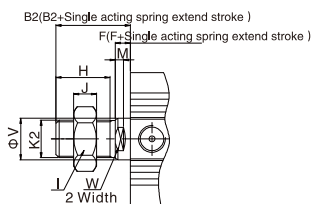

Bore /Sign	B2	F	H	I	J	K2	M	V	W
12	14	3.5	9	8	4	M5x0.8	3.5	6	5
16	15.5	3.5	10	10	5	M6x1.0	3	8	6
20	18.5	4.5	12	12	6	M8x1.25	4	10	8
25	22.5	5	15	17	6	M10x1.25	4.5	12	10
32	28.5	5	20.5	19	8	M14x1.5	4	16	14
40	28.5	5	20.5	19	8	M14x1.5	4	16	14
50	33.5	5	26	27	11	M18x1.5	4	20	17
63	33.5	5	26	27	11	M18x1.5	4	20	17
80	43.5	8	32.5	32	13	M22x1.5	6	25	22
100	43.5	8	32.5	36	13	M26x1.5	5.5	32	27

## SQ

### Compact Cylinder(Long Stroke Type)

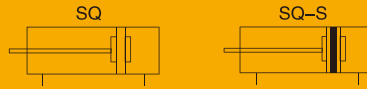

### Specifications

Bore(mm)	32	40	50	63	80	100
Acting type	Double Acting/Single Acting					
Working medium	Clean Air(40 μm filtration)					
Working pressure(MPa)	0.1~1.0(Double acting) / 0.2~1.0(Single acting)					
Garanteed pressure(MPa)	1.5					
Working temperature(°C)	-20~80(No freezing)					
Speed range(mm/s)	30~500					
Cushion type	Rubber cushion					
Port size ①	G1/8		G1/4		G3/8	

① PT、NPT port size is optional.

### How to Order?

Series No	Type No.	Bore	X Stroke	Adjustable Stroke	Magnet No-	Piston Rod Thread Type	Thread Type
SQA (Thread type)		32 40 50 ...	Details in stroke chart	10 20 30 40 50 75 100	Blank: No magnet S: With magnet	Blank: Female thread M: Male thread	Blank: G P: PT T: NPT
Blank: Basic type		100		50			
D: Double shaft type				75			
J: Double shaft and adjustable stroke type				100			
SA: Single acting spring extend							
SB: Single acting spring return							

#### Order Example:

SQA Series basic type cylinder, 40mm bore, 125mm stroke, with magnet, male thread on piston rod, G thread, ERP code is: SQA40X125-S-M

### Optional Accessories

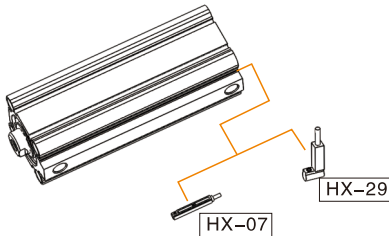

Note: Short stroke please use HX-29 series due to limited space.

### Stroke

Bore (mm)	Standard Stroke (mm)	Max. Stroke (mm)
32 40 50 63	125 150 175 200 250 300	300
80 100	125 150 175 200 250 300 350	350

Note: The dimensions of non-std stroke cylinder has the same dimensions as the next longer stroke std. stroke cylinder.  
e.g. 115mm stroke cylinder has the same dimensions of 125 std. stroke cylinder.

### Internal Structure

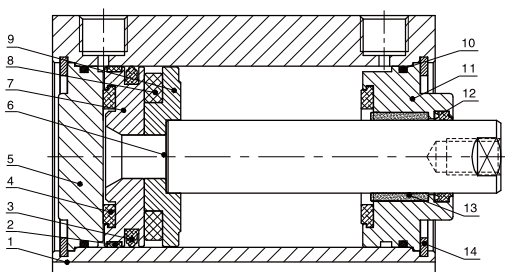

No.	Part Name	Material
1	Barrel	Aluminum alloy
2	Wear ring	PTEE
3	Piston seal	NBR
4	Anti-bump cushion	NBR/TPU
5	Rear cover	Aluminum alloy
6	Piston rod	S45C hard chrome carbon steel
7	Piston	Aluminum alloy
8	Magnet	Plasic
9	Magnet base	Aluminum alloy
10	O-ring	NBR
11	Head cover	Aluminum alloy
12	Piston rod seal	TPU
13	Self lubricating bearing	Bronze powder
14	C-type retainer ring	Spring steel

# SQ Series Compact Cylinder(Long Stroke Type)



## Main Dimension

SQA32~SQA100(S>100)

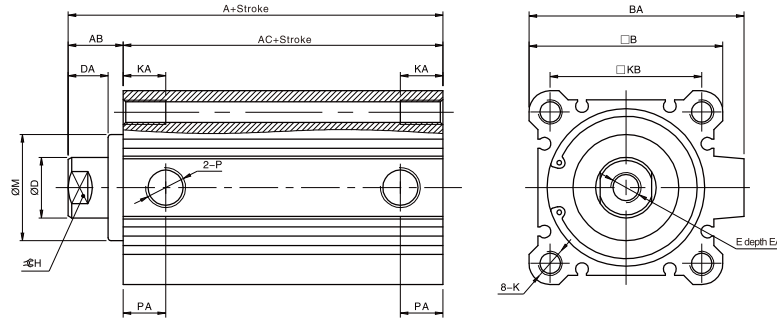

Bore/Sign	A	AB	AC	B	BA	D	DA	E	EA	H	K	KA	KB	M	P	PA
32	62.5	17	45.5	45	49.5	16	12	M8X1.25	13	14	M6X1.0	10	34	22	1/8"	12.5
40	72	17	55	52	57	16	12	M8X1.25	13	14	M6X1.0	10	40	28	1/8"	14
50	73.5	18	55.5	64	71	20	13	M10X1.5	15	17	M8X1.25	14	50	35	1/4"	14
63	75	18	57	77	84	20	13	M10X1.5	15	17	M10X1.5	18	60	35	1/4"	16.5
80	86	20	66	98	104	25	15	M16X2.0	21	22	M12X1.75	22	77	43	3/8"	19
100	97.5	22	75.5	117	123.5	32	17	M20X2.5	27	27	M12X1.75	22	94	59	3/8"	23

Note: With magnet and without magnet, the dimensions are same.

SQAD32~SQAD100(S>100)

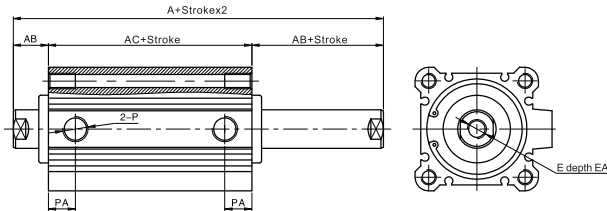

SQAJ32~SQAJ100(S>100)

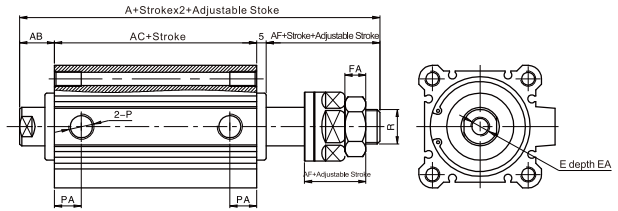

Bore/Sign	A(SQAD)		A(SQAJ)		AB	AC		AF	E	EA	FA	PA	R
	No magnet	With magnet	No magnet	With magnet		Standard	With magnet						
32	79.5	89.5	97.5	107.5	17	45.5	55.5	30	M8X1.25	13	8	12.5	M14X1.5
40	89	99	106	116	17	55	65	29	M8X1.25	13	8	14	M14X1.5
50	91.5	101.5	110.5	120.5	18	55.5	65.5	32	M10X1.5	15	11	14	M18X1.5
63	93	103	112	122	18	57	67	32	M10X1.5	15	11	16.5	M18X1.5
80	106	116	128	138	20	66	76	37	M16X2.0	21	13	19	M22X1.5
100	119.5	129.5	139.5	149.5	22	75.5	85.5	37	M20X2.5	27	13	23	M26X1.5

## Dimension of Male Thread

Φ32~Φ100(S>100)

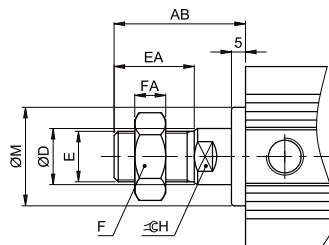

Bore/Sign	AB	D	E	EA	FA	F	H	M
32	38.5	16	M14X1.5	23.5	8	19	14	22
40	38.5	16	M14X1.5	23.5	8	19	14	28
50	43.5	20	M18X1.5	28.5	11	27	17	35
63	43.5	20	M18X1.5	28.5	11	27	17	35
80	53.5	25	M22X1.5	35.5	13	32	22	43
100	53.5	32	M26X1.5	35.5	13	36	27	59

3  
SQ  
(Long stroke)

## SQM

### Guide Rod Type Cylinder

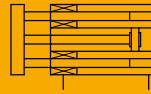

#### Specifications

Bore Size(mm)	12	16	20	25	32	40
Acting type	Double Acting					
Working medium	Clean Air (40 μ filtration)					
Working pressure (psi)	0.1~1.0					
Guaranteed pressure (psi)	1.5					
Working temperature	-20~80(No freezing)					
Speed range	30~500					
Stroke tolerance	+1.0 0					
Cushion type	Rubber cushion					
Port Size	M5X0.8				G1/8 ①	
Non-rotating tolerance	±0.2°			±0.1°		

① PT、NPT port size is optional.

#### How to Order?

Series No	Bore X Stroke	Magnet No	Thread Type
SQM	12 10 16 20 20 30 25 ... 32 40	Blank: No magnet S: With magnet	Blank: G P: PT T: NPT

Order Example:  
SQM series basic type cylinder, 25mm bore, 20mm stroke, with magnet, G thread, no mounting,  
ERP code is: SQM 25X20-S

#### Optional Accessories

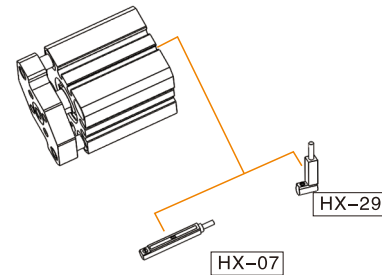

Note: Short stroke please use HX-29 series due to limited space.

#### Stroke

Bore (mm)	Standard Stroke (mm)	Max. Stroke (mm)
Double Acting	12、16 5 10 15 20 25 30	30
	20、25 5 10 15 20 25 30 35 40 45 50	50
	32、40 5 10 15 20 25 30 35 40 45 50 75 100	100

#### Internal Structure

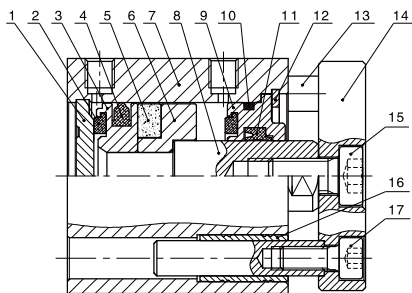

NO.	Part Name	Material
1	Back cover	Aluminum alloy
2	Anti-bump cushion	TPU
3	Piston	Aluminum alloy
4	Piston seal	NBR
5	Integral magnet	RbFeB
6	Magnet base	Aluminum alloy
7	Barrel	Aluminum alloy
8	Piston rod	Carbon steel
9	Rear cover	Aluminum alloy
10	O-ring	NBR
11	Piston rod seal	TPU
12	C type retainer ring	Spring steel
13	Rod	Stainless steel
14	Fixed plate	Aluminum alloy
15	Hex socket cap screw	Carbon steel
16	Sliding bearing	Brass
17	Hex socket cap screw	Carbon steel

# SQM Series Compact Cylinder/Guide Rod Type



## Main Dimension

### SQM $\Phi$ 12~25

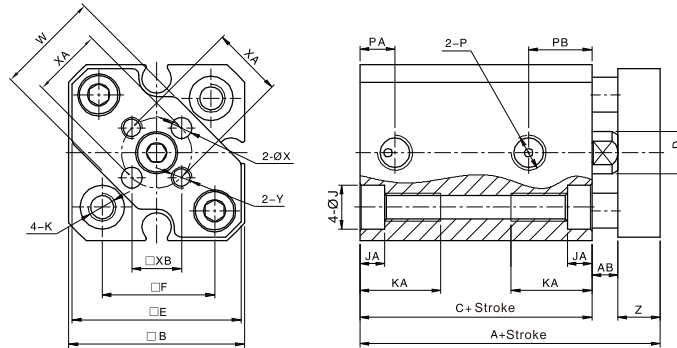

Bore/Sign	A		C		AB	B	D	E	F	J	JA	K
	Standard	With magnet	Standard	With magnet								
12	26.5	37.5	17	28	3.5	25	6	24	16	6.3	3.5	M4X 0.7 Throgh hole : $\Phi$ 3.4
16	28	40	18.5	30.5	3.5	29	8	28	20	6.5	3.5	M4X 0.7 Throgh hole : $\Phi$ 3.4
20	32	44	19.5	31.5	4.5	36	10	35	25.5	9	7	M6X 1.0 Throgh hole : $\Phi$ 5.2
25	35.5	45.5	22.5	32.5	5	40	12	39	28	9	7	M6X 1.0 Throgh hole : $\Phi$ 5.2

Bore/Sign	KA	P	PA	PB		W	X	XA	XB	Y	Z
12	11.5	M5X0.8	5	7.5	9	15	3	10	7.1	M3X0.5	6
16	11.5	M5X0.8	5.5	8	9.5	21	3	14	9.9	M3X0.5	6
20	18	M5X0.8	5.5	9	9	26	4	17	12	M4X0.7	8
25	17.5	M5X0.8	5.5	11	11	29	5	22	15.6	M5X0.8	8

### SQM $\Phi$ 32、 $\Phi$ 40

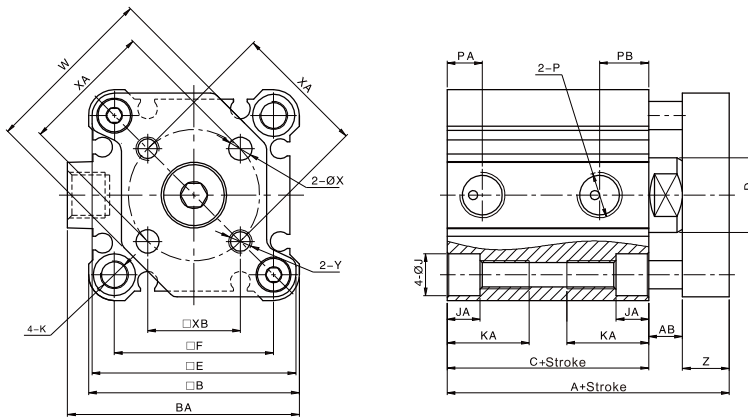

Bore/Sign	A		C		AB	B	BA	D	E	F	J	JA
	Standard	With magnet	Standard	With magnet								
32	40	50	23	33	7	45	49.5	16	43.5	34	9	3
40	46.5	56.5	29.5	39.5	7	52	57	16	50.5	40	9	3

Bore/Sign	K	KA	P	PA	PB	W	X	XA	XB	Y	Z
32	M6X 1.0 Throgh hole : $\Phi$ 5.2	17.5	1/8"	7.5	10.5	37	5	28	19.8	M5X0.8	10
40	M6X 1.0 Throgh hole : $\Phi$ 5.2	17.5	1/8"	8	11	46	5	33	23.3	M5X0.8	10

## SQK

### Rotary Clamp Cylinder



#### Specifications



Bore(mm)	16	20	25	32	40
Acting Type	Double Acting				
Working medium	Clean Air(40 μm filtration)				
Working pressure (MPa)	0.15~1.0(MPa)				
Guaranteed pressure (MPa)	1.5(MPa)				
Working temperature (°C)	-20~80(No freezing)				
Piston Speed (mm/s)	50~200				
Rotation angle	90° ± 10°				
Rotation Direction	Left rotation or right rotation				
Rotation Stroke (MM)	7.5	9.5		15	
Clamping stroke (MM)	10 20 30		10 20 30 50		
Stroke Tolerance	+1.0 0				
Cushion Type	Rubber cushion				
Port Size	M5x0.8			G1/8 ①	

① PT、NPT port size is optional.

#### How to Order?

Series No	Rotation Direction	Bore X Stroke	Magnet.No	Type No	Mounting Type	Thread Type
SQK	R:Right Rotation L:Left Rotation	16 10 20 20 25 30 32 50 40	S: With magnet  Blank: Basic Type(with arm) J: No arm		Blank: No mounting	Blank: G P : PT T : NPT

#### Order Example:

SQK series basic type cylinder, bore 25mm, stroke 20mm, right rotation, G thread, with arm, no mounting, ERP code is: SQKR25 x 20-S

#### Optional Accessories

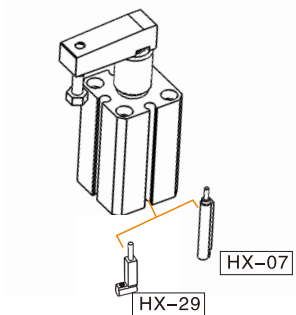

Note: Short stroke please use HX-29 series due to limited space.

#### Definition of Rotation Direction and Rotation Angle

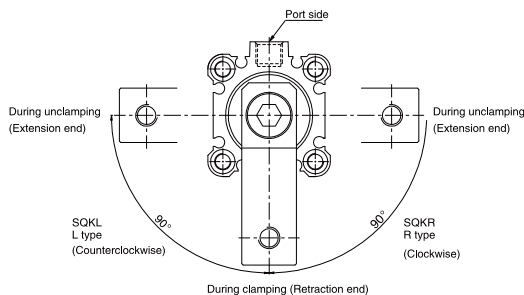

#### Stroke

	Bore(mm)	Clamping Stroke(mm)	Max.Clamping Stroke(mm)
Double acting	16、20、25	10 20 30	30
	32、40	10 20 30 50	50

# SQK Series Rotary Clamp Cylinder



## Internal Structure

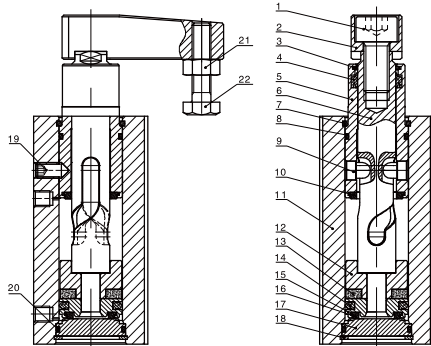

No.	Part Name	Material	No.	Part Name	Material
1	Hex Socket Cap Screw	Carbon steel	12	Magnet Base	Aluminium alloy
2	Clamping Arm	Steel	13	Intergral Magnet	NdFeB/Plastic
3	Dust Scraping Ring	Free Machining Steel	14	Piston Seal	NBR
4	Piston Rod Seal	NBR	15	Piston	Aluminium alloy
5	Head Cover	Aluminium alloy	16	Anti-collision Gasket	PTEE
6	Piston Rod	Special material	17	Rear Cover	Aluminium alloy
7	Check Ring	Spring Steel/Stainless Steel	18	Check Ring for C Type Hole	Spring Steel
8	O-ring	NBR	19	Hex Socket Tighten Screw	Carbon steel
9	Rolling Stopper Pin	Special material	20	O-ring	NBR
10	Anti-collision Gasket	TPU	21	Hex Nut	Carbon steel
11	Barrel	Aluminium alloy	22	Hex bolt	Stainless Steel

## Main Dimension

SQK  $\Phi 16$

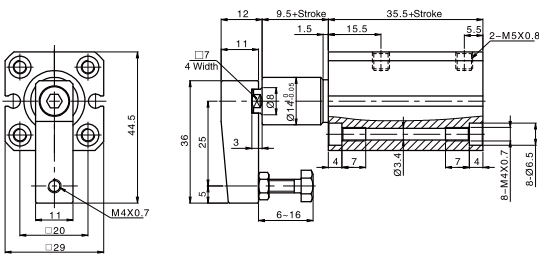

SQK  $\Phi 20$ ,  $\Phi 25$

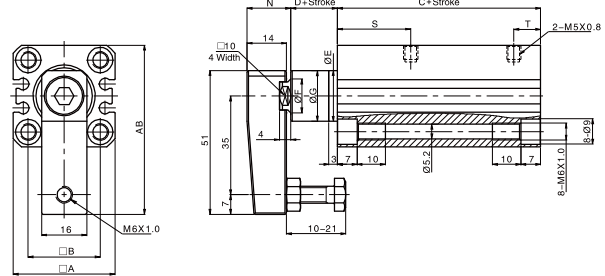

Bore/Sign	A	AB	B	C	D	E	F	G	N	S	T
20	36	60	25.5	62	6.5	18.0 <sub>+0.05</sub>	12	17.9	15.5	26	9.5
25	40	62	28	63	6.5	23.0 <sub>+0.05</sub>	12	22.5	15.5	27.5	10

SQK  $\Phi 32$ ,  $\Phi 40$

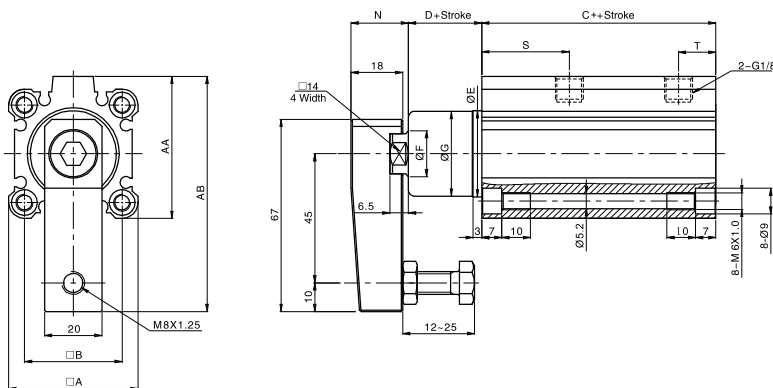

Bore/Sign	A	AA	AB	B	C	D	E	F	G	N	S	T
32	45	49.5	82	34	71.5	15.5	30.0 <sub>+0.06</sub>	16	29.5	20	30.5	13
40	52	51	86	40	65	23	30.0 <sub>+0.06</sub>	16	29.5	20	27.5	8

## Installation and Use

1. Dirty substances in the pipe must be eliminated before cylinder is connected with pipeline to prevent the entrance of impurities into the cylinder.
2. The medium used by cylinder shall be filtered to 40 μ m or below.
3. Anti-freezing measure shall be adopted under low temperature environment to prevent moisture freezing.
4. If the cylinder is dismantled and stored for a long time, please conduct anti-rust treatment to the surface. Anti-dust jam cap shall be added in air inlet and outlet ports.
5. To insure the life-span of cylinder and jig, please use flow control valve to control the speed of cylinder.
6. The method of installation are mounted by flange on top or bottom.

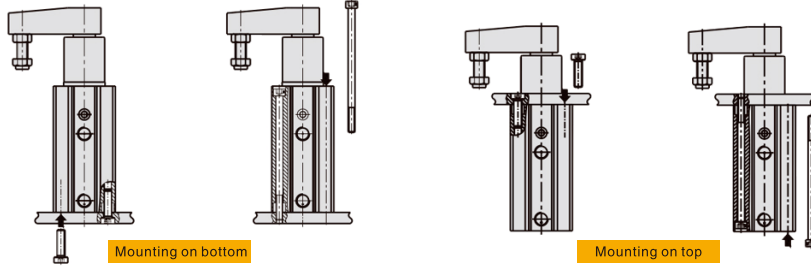

7. Please clean the piston rod and dust scraping ring to protect the cylinder.
8. Magnetic switch of SQK is same as SQ series cylinder.
9. Please install the cylinder as below diagram.

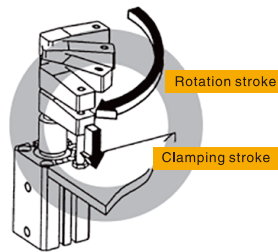

10. The installation method as the diagram below is wrong, and will injure the cylinder and shorten the cylinder life.

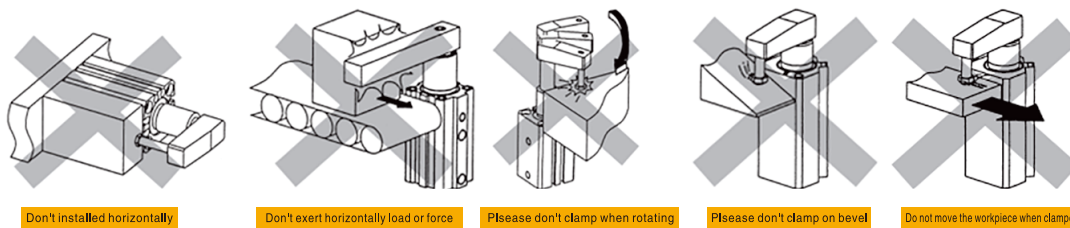

11. Please follow the diagram below on right side to assemble/disassemble the rocker by spanner and allen wrench, don't hold the body to assemble /disassemble rocker, or will damage the cylinder.

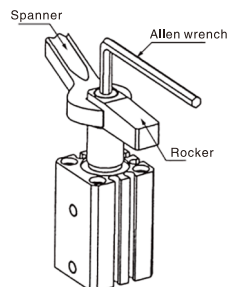

# EU Series Free Mount Cylinder



## EU

### Free Mount Cylinder

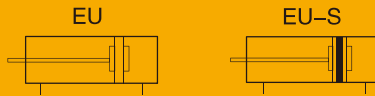

### Specifications

Bore(mm)	6	10	16	20	25	32
Acting type	Double acting/Single acting					
Working medium	Clean air(40 μm filtration)					
Working pressure(MPa)	0.1~1.0(Double acting) / 0.2~1.0(Single acting)					
Guaranteed pressure(Mpa)	1.5					
Working temperature(°C)	-20~80( No freezing)					
Speed range(mm/s)	30~500					
Cushion type	Rubber cushion					
Port size	M5 x 0.8					G1/8"①

① PT、NPT port size is optional.

### How to Order?

Series No	Type No	Bore	X Stroke	- Adjustable Stroke	- Magnet No	- Thread Type
EU	Blank: Basic type	6	5	10	Blank: No magnet S: With magnet	Blank: G P: PT T: NPT
	D: Double shaft type	10	10	20		
	J: Double shaft and adjustable stroke type	16	15	30		
	SA: Single acting spring extend	...	...	...		
	SB: Single acting spring return	32	80	...		

#### Order Example:

EU Series single acting spring return cylinder, 32mm bore, 30mm stroke, with magnet, NPT thread. ERP code is: EUSB 32X30-S-T

### Optional Accessories

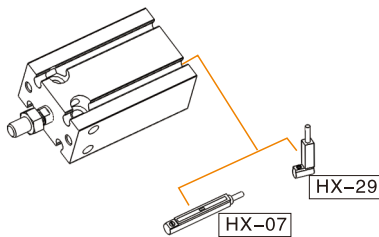

Note: Short stroke please use HX-29 series due to limited space.

### Stroke

Bore (mm)	Standard Stroke (mm)										Max. Stroke (mm)	
6	5	10	15	20	25	30	35					35
10	5	10	15	20	25	30	35	40				40
16	5	10	15	20	25	30	40	50	60			60
20	5	10	15	20	25	30	40	50	60	70	80	80
25	5	10	15	20	25	30	40	50	60	70	80	80
32	5	10	15	20	25	30	40	50	60	70	80	80

Note: 1. The maximum range of non – standard stroke is adjusted from the next longer stroke (add gasket inside), which has the same dimensions as the next longer stroke std. stroke cylinder. e.g. 23mm non – standard stroke cylinder is adjusted from 25 standard stroke cylinder, they have the same dimensions.  
2. When ordering the stroke is greater than the Max. stroke, please contact the company.

### Internal Structure

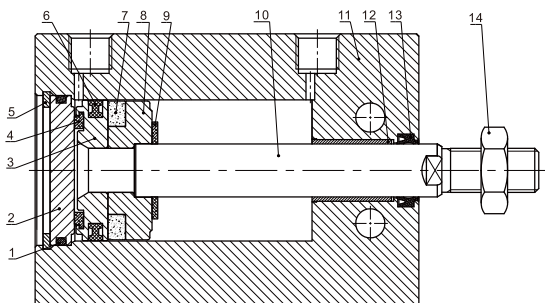

No.	Part Name	Material
1	O-ring	NBR
2	Rear cover	Aluminum alloy
3	Piston	Aluminum alloy
4	Anti-bump cushion	TPU
5	C type retainer ring	Spring steel
6	Piston seal	NBR
7	Magnet	NdFeB
8	Magnet base	Aluminum alloy
9	Anti-bump cushion	TPU/NBR
10	Piston rod	Stainless steel
11	Barrel	Aluminum alloy
12	Bearing	Compound material
13	Piston rod seal	TPU/NBR
14	Nut	Carbon steel

## Installation

Parallel-shaft model (body connected)

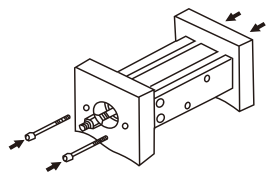

Vertical-shaft model (with through bore in the body)

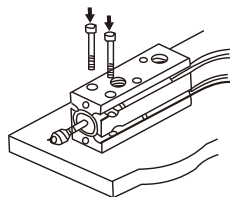

Side-connected (with through bore in the body)

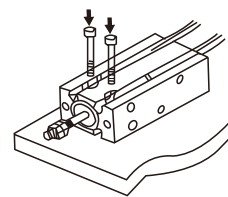

## Main Dimension

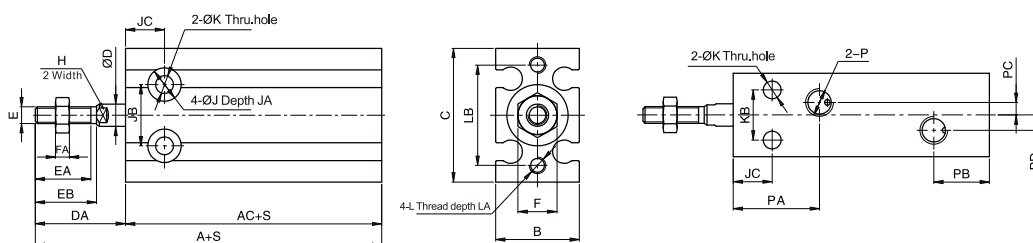

Bore/Sign	A(No magnet)	A(With magnet)	AC(No magnet)	AC(With magnet)	B	C	D	DA	E	EA	EB						
6	46	46	33	33	13	22	3	13	M3X0.5	7	8						
10	52	52	36	36	15	24	4	16	M4X0.7	10	11						
16	46	56	30	40	20	32	6	16	M5X0.8	11	12.5						
20	55	65	36	46	26	40	8	19	M6X1.0	12	14						
25	63	73	40	50	32	50	10	23	M8X1.25	15.5	18						
32	69	79	42	52	40	62	12	27	M10X1.25	19.5	22						
Bore/Sign	F	FA	H	J	JA	JB	JC	K	KB	L	LA	LB	P	PA	PB	PC	PD
6	5.5	2.5	-	5.8	4.5	10	7	3.2	7	M3X0.5	5	17	M5X0.8	15	10	-	-
10	7	3	-	5.8	4.8	11	7	3.2	9	M3X0.5	5	18	M5X0.8	15.5	10	-	-
16	8	4	5	7.5	6.5	14	7	4.3	12	M4X0.7	6	25	M5X0.8	15.5	11.5	2	2
20	10	5	6	9.5	8	16	9	5.5	16	M5X0.8	8	30	M5X0.8	21	10	4.5	5.5
25	12	6	8	9.5	9	20	10	5.5	20	M5X0.8	8	38	M5X0.8	23	10	4.5	6
32	17	6	10	11	11.5	24	11	6.6	24	M6X1.0	9	48	1/8"	23	12.5	4.5	9

Note: When bore is  $\phi 6$ , 10mm, EU cylinder with double nuts.

# EUK Series Free Mount Cylinder



## EUK

### Free Mount Cylinder

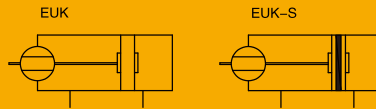

### Specifications

Bore(mm)	10	16	20	25	32
Acting type	Double acting/Single acting				
Working medium	Clean air(40 μm filtration)				
Working pressure(MPa)	0.1~1.0(Double acting) / 0.2~1.0(Single acting)				
Guaranteed pressure(Mpa)	1.5				
Working temperature(°C)	-20~80( No freezing)				
Speed range(mm/s)	Double acting: 30~500		Single acting: 50~500		
Stroke tolerance	+1.0 0				
Cushion type	Rubber cushion				
Port size	M5 x 0.8			G1/8 ①	

① PT, NPT port size is optional.

### How to Order?

Series No	Type No	Bore	X	Stroke	Adjustable Stroke	Magnet No	Thread Type
EUK	Blank: Basic type D: Double shaft type J: Double shaft and adjustable stroke type SA: Single acting spring extend SB: Single acting spring return	10 16 ... 32	5 10 15 ...	10 20 30 ...	Blank: No magnet S: With magnet	Blank: G	

#### Order Example:

EUK Series basic type cylinder, 32mm bore, 30mm stroke, with magnet, G thread, ERP code is: EUK 32X30-S

### Optional Accessories

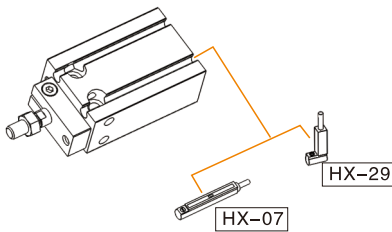

Note: Short stroke please use HX-29 series due to limited space.

### Stroke

Bore (mm)	Standard Stroke (mm)										Max. Stroke (mm)
10	5	10	15	20	25	30	35	40			40
16	5	10	15	20	25	30	40	50	60		60
20	5	10	15	20	25	30	40	50	60	70	80
25	5	10	15	20	25	30	40	50	60	70	80
32	5	10	15	20	25	30	40	50	60	70	80

Note: 1. The dimensions of non-std stroke cylinder has the same dimensions as the next longer stroke std. stroke cylinder.  
e.g. 23mm stroke cylinder has the same dimensions of 25 std. stroke cylinder  
2. When ordering the stroke is greater than the Max. stroke, please contact the company.

### Internal Structure

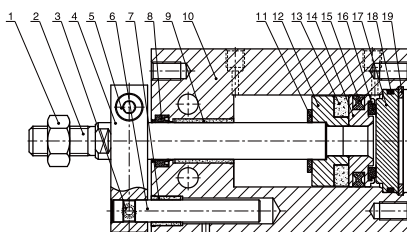

No.	Part Name	Material	No.	Part Name	Material
1	Nut	Carbon steel	11	Bumper	TPU/NBR
2	Piston rod	Stainless steel	12	Magnet holder	Aluminum alloy
3	Socket head screw	Carbon steel	13	Magnet	NdFeB
4	No-rotating plate	Aluminum alloy	14	Piston	Aluminum alloy
5	Hexagon socket cap screw	Carbon steel	15	Piston seal	NBR
6	Fixed rod	Stainless steel	16	Bumper	TPU
7	Self lubricating bearing	Compound material/brass	17	Rear cover	Aluminum alloy
8	Piston rod seal	TPU/NBR	18	O-ring	NBR
9	Bearing	Compound material	19	C-clip	Spring steel
10	Barrel	Aluminum alloy			

## Main Dimension

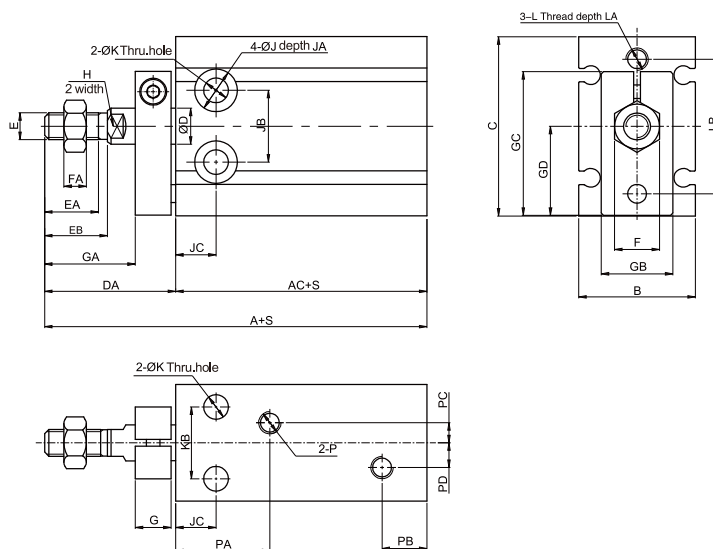

Bore/Sign	A(No magnet)	A(With magnet)	AC(No magnet)	AC(With magnet)	B	C	D	DA	E	EA	EB	F									
10	57	57	36	36	15	24	4	21	M4X0.7	10	11	7									
16	56	66	30	40	20	32	6	26	M5X0.8	11	12.5	8									
20	65	75	36	46	26	40	8	29	M6X1.0	12	14	10									
25	73	83	40	50	32	50	10	33	M8X1.25	15.5	18	12									
32	84	94	42	52	40	62	12	42	M10X1.25	19.5	22	17									
Bore/Sign	FA	G	GA	GB	GC	GD	H	J	JA	JB	JC	K	KB	L	LA	LB	P	PA	PB	PC	PD
10	3	8	12	13	20.4	11.8	-	5.8	4.8	11	7	3.2	9	M3X0.5	5	18	M5X0.8	15.5	10	-	-
16	4	8	17	13	26.3	15.7	5	7.5	6.5	14	7	4.3	12	M4X0.7	6	25	M5X0.8	15.5	11.5	2	2
20	5	8	20	16	32	19.8	6	9.5	8	16	9	5.5	16	M5X0.8	8	30	M5X0.8	21	10	4.5	5.5
25	6	10	22	19	40	24.8	8	9.5	9	20	10	5.5	20	M5X0.8	8	38	M5X0.8	23	10	4.5	6
32	6	12	29	24	49	30.8	10	11	11.5	24	11	6.6	24	M6X1.0	9	48	1/8"	23	12.5	4.5	9

## EUP

### Panel Cylinder

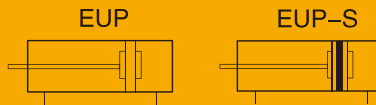

### Specifications



Bore(mm)	6	10	16
Acting Type	Double Acting		
Working Medium	Clean Air(after 40 μ m filtration)		
Working Pressure(MPa)	0.1-0.7		
Guaranteed Pressure(MPa)	1.05		
Working Temperature(°C)	-20~80(No freezing)		
Piston Speed(mm/s)	30-500		
Stroke tolerance	+1.0 0		
Cushion	Rubber cushion		
Port Size	M3×0.5		M5×0.8

### How to order?

Series No.	Type No.	Bore X Stroke	Magnet No.	Piston Rod Thread Type	Mounting Type	
EUP	Blank: Basic type H: Rear hinge seat type	6 10 16	5 10 15 ...	Blank: No magnet S: With magnet	Blank: Male thread N: No thread	Blank: No CF CR

#### Order Example:

EUP series basic type cylinder, bore 10, stroke 50, with magnet, no mounting type.  
The ERP code is: EUP10X50-S

### Optional Accessories

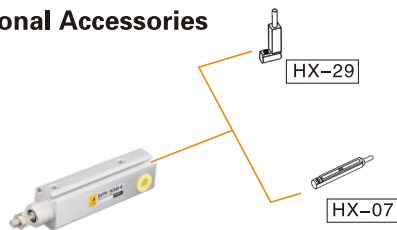

Note: Short stroke please use HX-29 series due to limited space.

### Stroke

	Bore(mm)	Standard Stroke(mm)	Max.Stroke(mm)
Double Acting	6	5 10 15 20 25	25
	10	5 10 15 20 25 30 35 40	40
	16	5 10 15 20 25 30 35 40	40

### Internal Structure

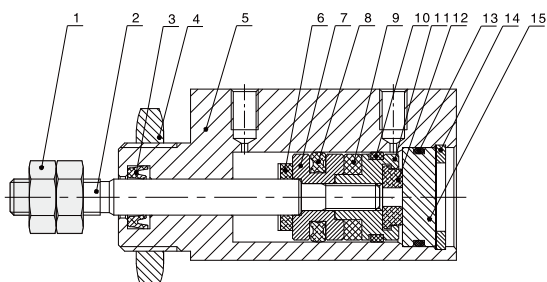

No.	Part Name	Material
1	Nut	Carbon steel
2	Piston Rod	SUS 304 hard chrome carbon steel
3	Front Cover o-ring	NBR
4	Nut	Carbon steel
5	Barrel	Aluminum Alloy
6	Anti-bump cushion	TPU 16: NBR
7	Piston	6: SUS304 10: Cu 16: Aluminum Alloy
8	Piston seal	NBR
9	Magnet	NdFeB
10	Wearing ring	PTFE
11	Magnet Seat	SUS304 16: Aluminum Alloy
12	Anti-bump cushion	TPU 16: NBR
13	O-ring	NBR
14	Snap ring	Spring steels
15	Rear Cover	Aluminum Alloy

## Main Dimensions

### EUP

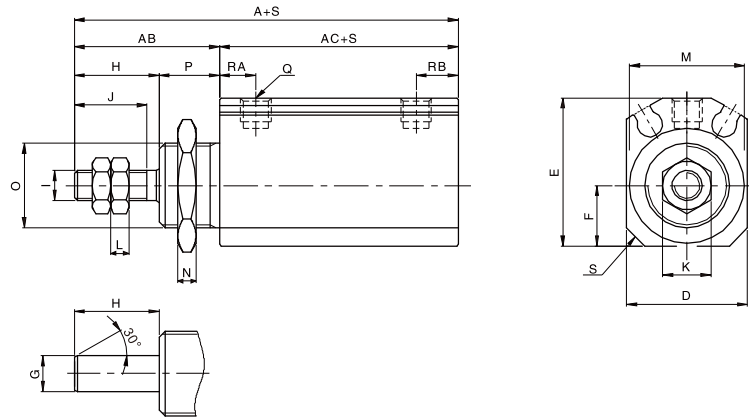

No thread piston rod

Bore/Sign	A		AB	AC		D	E	F	G	H	I	J	K	L	M	N	O	P	Q	RA	RB	S
	No magnet	With magnet		No magnet	With magnet																	
6	33	38	17	16	21	14	16.5	6	3	9	M3X0.5	7	5.5	2.5	12.7	3	M10X1.0	8	M3X0.5	4.6	6.5	2
10	39.5	44.5	20	19.5	24.5	15	19	7	4	12	M4X0.7	10	7	3	17	3	M12X1.0	8	M3X0.5	6	7	2.5
16	43.5	48.5	24	19.5	24.5	20	24.5	10	6	14	M5X0.8	12	8	3	19	3	M14X1.0	10	M5X0.8	6	7	3

### EUPH

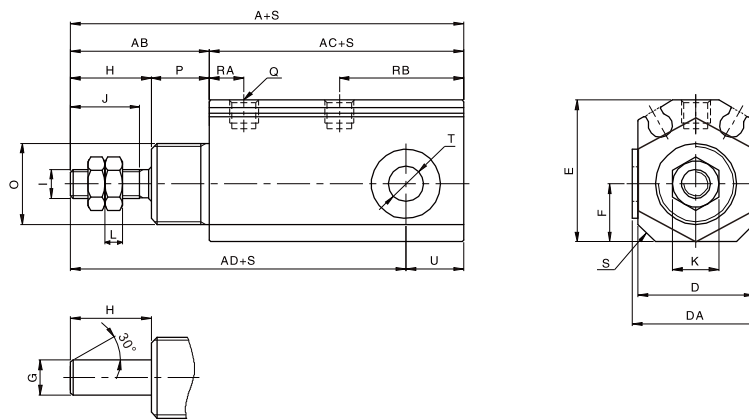

No thread piston rod

Bore/Sign	A		AB	AC		AD		D	DA	E	F	G	H	I	J	K	L
	No magnet	With magnet		No magnet	With magnet	No magnet	With magnet										
6	38	43	17	21	26	34	39	14	-	16.5	6	3	9	M3X0.5	7	5.5	2.5
10	50.5	55.5	20	30.5	35.5	44	49	15	17	19	7	4	12	M4X0.7	10	7	3
16	58	63	24	34	39	48	53	20	22	24.5	10	6	14	M5X0.8	12	8	3
Bore/Sign	O		P		Q		RA		RB		S		T		U		
6	M10X1.0		8		M3X0.5		4.6		11.5		2		$\varnothing_{3.7}^{+0.05}$		4		
10	M12X1.0		8		M3X0.5		6		18		2.5		$\varnothing_{5.0}^{+0.065}$		6.5		
16	M14X1.0		10		M5X0.8		6		21.5		3		$\varnothing_{6.0}^{+0.065}$		10		

# EUP Series Panel Cylinder



## Mounting Type

### LB

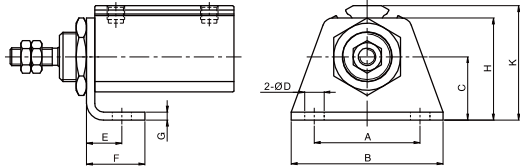

Bore/Sign	A	B	C	D	E	F	G	H	K
FJ-EUP6LB	20	28	11	3.4	6.5	10.5	1.6	19	21.5
FJ-EUP10LB	24	33	13	4.5	7	12	1.6	22	25
FJ-EUP16LB	30	43	18	5.5	10	16.5	2.3	29	32.5

### FA

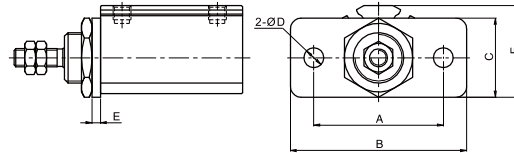

Bore/Sign	A	B	C	D	E	F
FJ-EUP6FA	24	32	16	3.4	1.6	18.5
FJ-EUP10FA	28	37	18	4.5	1.6	21
FJ-EUP16FA	36	49	22	5.5	2.3	25.5

### CR(Round head)

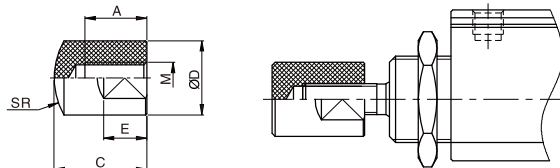

### CF(Flat head)

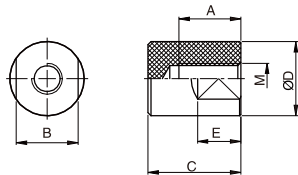

Bore/Sign	A	B	C	D	E	M	SR
FJ-EUP6CF/CR	6	6	11	8	5	M3X0.5	8
FJ-EUP10CF/CR	8	8	13	10	6	M4X0.7	10
FJ-EUP16CF/CR	10	10	15	12	7	M5X0.8	12

## Installation and Use

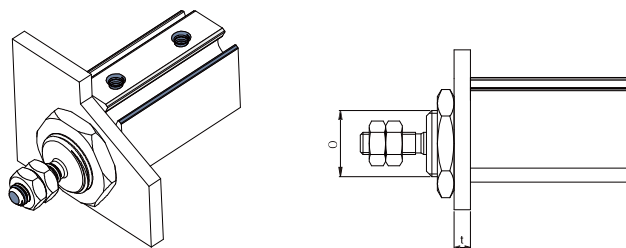

Bore	Thread specification(t)	Max. Thickness(t)	Panel hole size
6	M10X1.0	4	Ø10.5
10	M12X1.0	4	Ø12.5
16	M14X1.0	6	Ø14.5

## EUM

Minitype Free Mount Cylinder

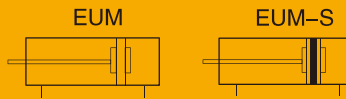

### Specifications

Bore(mm)	6	8	10	12	16	20
Acting Type	Double Acting					
Working Medium	Clean Air(after 40 μ m filtration)					
Working Pressure(MPa)	0.15~0.7					
Guaranteed Pressure(MPa)	1.05					
Working Temperature(°C)	-20~80(No freezing)					
Piston Speed(mm/s)	30~500					
Cushion	None			Rubber cushion		
Stroke tolerance	+1.0 0					
Port Size	M3 x 0.5					M5 x 0.8

### How to order?

Series No.	Type No.	Bore	X Stroke	Magnet No.	Piston Rod Thread Type	Mounting Type
EUM	Blank: Basic type	6 8 10 12 16 20	4 6 8 .....	Blank: No magnet S: With magnet	Blank: Female thread N: Male thread	Blank: Lateral mounting R: Axial mounting ( Note:ø6,ø8,ø10 is not available )

#### Order Example:

EUM series basic type cylinder, bore 10, stroke 20, with magnet, male thread  
The ERP code is: EUM10X20-S-M

### Optional Accessories

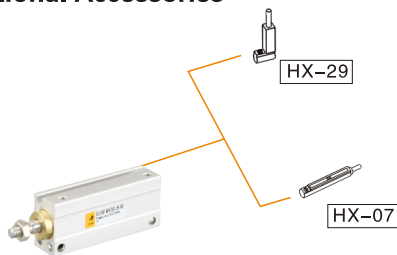

Note: Short stroke please use HX-29 series due to limited space.

### Stroke

Bore(mm)	Standard Stroke(mm)	Max.Stroke(mm)
6	4 6 8 10 15 20 25 30	30
8	4 6 8 10 15 20 25 30	30
10	4 6 8 10 15 20 25 30	30
12	5 10 15 20 25 30	30
16	5 10 15 20 25 30	30
20	5 10 15 20 25 30 35 40 45 50	50

### Internal Structure

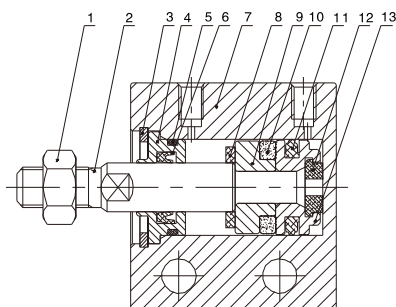

No.	Part Name	Material
1	Nut	Carbon steel
2	Piston Rod	SUS 304 hard chrome carbon steel
3	Snap ring	Spring steels
4	Head cover	Cu/Aluminum alloy
5	O-ring	NBR
6	Head cover o-ring	NBR
7	Barrel	Aluminum Alloy
8	Anti-bump cushion	NBR
9	Magnet Seat	SUS304/Aluminum alloy
10	Magnet	NdFeB
11	Piston seal	NBR
12	Anti-bump cushion	TPU
13	Piston	SUS304/Cu/Aluminum alloy

# EUM Series Minitype Free Mount Cylinder



## Main Dimensions

### Ø6-Ø10

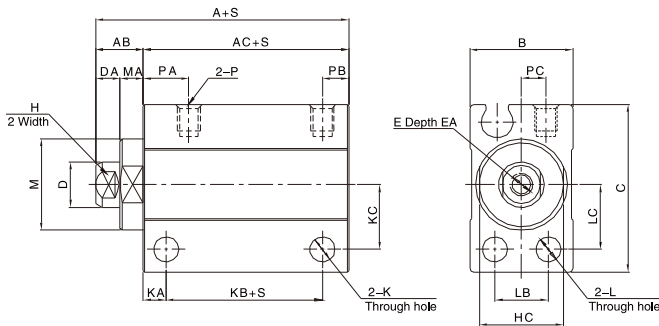

	A		AB	AC		B	C	D	DA	E	EA	H	HC
	No magnet	With magnet		No magnet	With magnet								
6	19	24	6	13	18	13	19	4	3	M2.5X0.45	5	3.5	8
8	19	24	6	13	18	13	21	5	3	M3X0.5	6	4.5	10
10	19	24	6	13	18	13.5	22	6	3	M3X0.5	6	5	11

Bore/Sign	K	KA	KB		KC	L	LB	LC	M	MA	P	PA	PB	PC
			No magnet	With magnet										
6	3.3	3	6.5	11.5	7	3.3	7	7	9	3	M3X0.5	6	3.5	3
8	3.3	3	6.5	11.5	8	3.3	7	8	11	3	M3X0.5	6	3.5	3
10	3.3	3	6.5	11.5	8.5	3.3	7	8.5	12	3	M3X0.5	6	3.5	3.2

### Ø6-Ø10 (Male Dimensions)

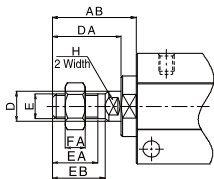

Bore/Sign	AB	D	DA	E	EA	EB	FA	H
6	12.5	4	9.5	M3X0.5	5.5	6.5	2.5	3.5
8	14.5	5	11.5	M4X0.7	7	8.5	3	4.5
10	16.5	6	13.5	M5X0.8	9	10.5	4	5

Note: Not marked dimensions are same sizes as the female type.

### Ø12-Ø20 (Lateral Type)

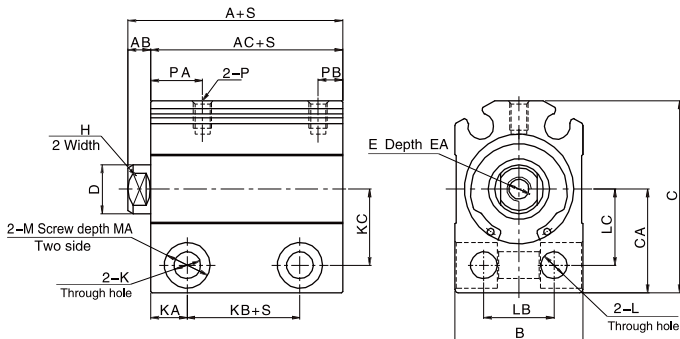

Bore/Sign	A		AB	AC		B	C	CA	D	E	EA	H	K	KA
	No magnet	With magnet		No magnet	With magnet									
12	19	24	3.5	15.5	20.5	17	28.5	15.5	6	M3X0.5	6	5	4.4	6
16	20	25	3.5	16.5	21.5	21	31.5	17	8	M4X0.7	8	6	4.4	6
20	24	29	4.5	19.5	24.5	25	38.5	21	10	M5X0.8	7	8	5.5	7

Bore/Sign	KB		KC	L	LB	LC	M	MA	P	PA	PB
	No magnet	With magnet									
12	3.5	7.5	11	4.4	8	11	7.5	7	M3X0.5	7.5	4
16	4	8.5	12.5	4.4	11.5	12.5	7.5	7	M3X0.5	8.5	4
20	5.5	9.5	15.5	5.5	13.5	15.5	9.5	9	M5X0.8	8.5	5.5

### Ø12-Ø20 (Axial Type)

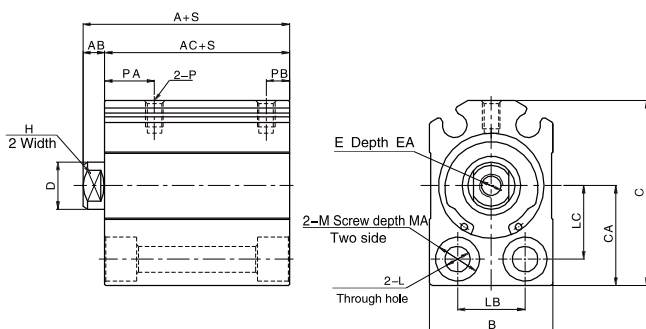

Bore/Sign	A		AB	AC		B	C	CA	D	E	EA	H
	No magnet	With magnet		No magnet	With magnet							
12	19	24	3.5	15.5	20.5	17	28.5	15.5	6	M3X0.5	6	5
16	20	25	3.5	16.5	21.5	21	31.5	17	8	M4X0.7	8	6
20	24	29	4.5	19.5	24.5	25	38.5	21	10	M5X0.8	7	8

Bore/Sign	LB	LC	M	MA	P	PA	PB
16	11.5	12.5	7.5	5.5	M3X0.5	8.5	4
20	13.5	15.5	9.5	6.5	M5X0.8	8.5	5.5

### Ø12-Ø20 (Male Dimensions)

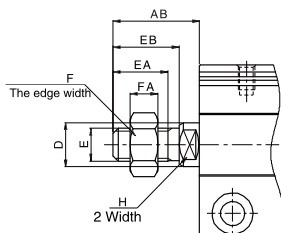

Bore/Sign	AB	D	E	EA	EB	F	FA	H
12	14	6	M5X0.8	9	10.5	8	4	5
16	15.5	8	M6X1.0	10	12	10	5	6
20	18.5	10	M8X1.25	12	14	12	6	8

Note: Not marked dimensions are same sizes as the female type.

## How to Order?





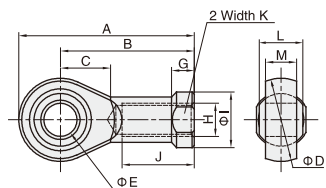
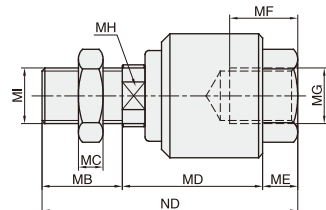
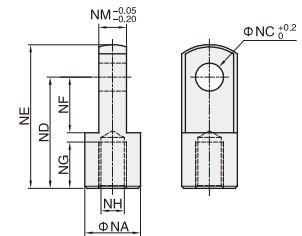
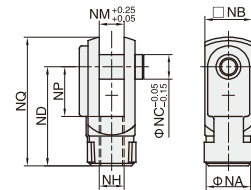
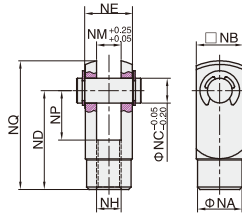

Series No.	Thread Size	Thread Length	Accessory Code
FJ: Accessory	M6: M6 M8: M8 M10: M10 M12: M12 M16: M16	M20: M20 M27: M27 M36: M36 M42: M42 M48: M48	1: 1 1.25: 1.25 1.5: 1.5 2.0: 2.0
			IJ: I fitting YJ: Y fitting YCJ: Y fitting FD: Floating fitting BJ: Bearing fitting

## Dimensions of Cylinder Accessory

		Model/Sign	NA	NB	NC	ND	NE	NH	NM	NP	NQ	Material		
Y Fitting		FJ-M6X1YJ	10	12	6	24	-	M6X1	6	12	31	Carbon steel		
		FJ-M8X1.25YJ	14	16	8	32	-	M8X1.25	8	16	42	Carbon steel		
		FJ-M10X1.25YJ	18	20	10	40	-	M10X1.25	10	20	52	Carbon steel		
		FJ-M12X1.25YJ	20	24	12	48	-	M12X1.25	12	24	62	Carbon steel		
		FJ-M16X1.5YJ	26	32	16	64	-	M16X1.5	16	32	83	Carbon steel		
		FJ-M20X1.5YJ	34	40	20	80	-	M20X1.5	20	40	105	Carbon steel		
		FJ-M27X2YJ	42	55	30	110	-	M27X2	30	55	148	Carbon steel		
		FJ-M36X2YJ	60	70	35	144	-	M36X2	35	72	188	Carbon steel		
		FJ-M42X2YJ	70	85	40	168	-	M42X2	40	84	232	Carbon steel		
		FJ-M48X2YJ	80	90	50	192	-	M48X2	50	96	265	Carbon steel		
		FJ-M12X1.25YJ-TBC	21	25	12	48	23	M12X1.25	12	22	60	Carbon steel		
		FJ-M16X1.5YJ-TBC	28	32	16	62	30	M16X1.5	16	30	78	Cast Steel		
FJ-M20X1.5YJ-TBC	36	40	20	79	38	M20X1.5	20	39	90	Cast Steel				
YC Fitting		FJ-M6X1 YCJ	10	12	6	24	-	M6X1	6	12	31	Carbon steel		
		FJ-M8X1.25 YCJ	14	16	8	32	-	M8X1.25	8	16	42	Carbon steel		
		FJ-M10X1.25 YCJ	18	20	10	40	-	M10X1.25	10	20	52	Carbon steel		
		FJ-M12X1.25 YCJ	20	24	12	48	-	M12X1.25	12	24	62	Carbon steel		
		FJ-M16X1.5 YCJ	26	32	16	64	-	M16X1.5	16	32	83	Carbon steel		
		FJ-M20X1.5 YCJ	34	40	20	80	-	M20X1.5	20	40	105	Carbon steel		
		FJ-M27X2 YCJ	42	55	30	110	-	M27X2	30	55	148	Carbon steel		
I Fitting		FJ-M6X1 IJ	12	6	24	31	12	10	M6X1	6	Carbon steel			
		FJ-M8X1.25 IJ	16	8	30	40	11	15	M8X1.25	8	Carbon steel			
		FJ-M10X1.25 IJ	20	10	40	52	15	20	M10X1.25	10	Carbon steel			
		FJ-M12X1.25 IJ	24	12	48	67	24	20	M12X1.25	12	Carbon steel			
		FJ-M16X1.5 IJ	32	16	64	89	32	23	M16X1.5	16	Carbon steel			
		FJ-M20X1.5 IJ	40	20	80	112	40	30	M20X1.5	20	Carbon steel			
		FJ-M27X2 IJ	55	30	110	155	50	55	M27X2	30	Carbon steel			
		FJ-M12X1.25IJ-TBC	23.5	12	48	60	24	20	M12X1.25	12	Carbon steel			
		FJ-M16X1.5IJ-TBC	28.5	16	62.5	78.5	31.5	25	M16X1.5	16	Carbon steel			
		FJ-M20X1.5IJ-TBC	38	20	81	100	37.5	30	M20X1.5	20	Carbon steel			
Floating Fitting		FJ-M6X1.0FD	35	13	5	17	5	8	M6X1.0	7	M6X1.0			
		FJ-M8X1.25FD	54	21	6	27	6	12	M8X1.25	8	M8X1.25			
		FJ-M10X1.25FD	59.5	21	6	30.5	8	13	M10X1.25	10	M10X1.25			
		FJ-M12X1.25FD	64.5	21	7	35.5	8	15	M12X1.25	12	M12X1.25			
		FJ-M16X1.5FD	90.5	30	8	47.5	13	23	M16X1.5	15	M16X1.5			
		FJ-M20X1.5FD	102	32	10	57	13	28	M20X1.5	22	M20X1.5			
		FJ-M27X2.0FD	120	36	12	67	17	35	M27X2.0	30	M27X2.0			
Bearing Fitting		FJ-M6X1BJ	40.5	31	11	20	6	7	M6X1	13	18	11	9	7
		FJ-M8X1.25BJ	48	36	12	24	8	7.5	M8X1.25	16	20	14	12	9
		FJ-M10X1.25BJ	57.5	44	15.5	28	10	8	M10X1.25	19	25	17	14	10.5
		FJ-M12X1.25BJ	66.5	51.5	17	32	12	9.5	M12X1.25	22	25	19	16	12
		FJ-M16X1.5BJ	85	65	25	40	16	11	M16X1.5	27	35	24	21	15
		FJ-M20X1.5BJ	102	77	30	50	20	12.5	M20X1.5	34	40	30	25	18
		FJ-M27X2BJ	145	109	40.5	70	30	18.5	M27X2	50	60	43	37	25
		FJ-M36X2BJ	168	127.5	39.5	80	35	19	M36X2	57	70	49.5	43	28.5



## Magnet Switch Table

For Cylinder Model	Bore size	Two wire electronic type	Three wire electronic NPN type	Three wire electronic PNP type	Two wire reed switch type	Reed Switch Photo
SD	Φ20-100 ( Front face installation )	HX-01D	HX-01N	HX-01P	HX-01R	
SE/SHY/SHZ/ESWT	Full series					
SQ/SQM/EU/EUK/ EUM/EUP/SF/SFM/ SQK/SG//EMQ/ELS/ ELQ/EXH/ESWT *SHY/SHZ(except Φ 10)	Full series	HX-07D HX-29D	HX-07N HX-29N	HX-07P HX-29P	HX-07R	
Note: Short stroke please use HX-29 series due to limited space.						
SD/EN	Full series ( Side installation )	HX-11D	HX-11N	HX-11P	HX-11R	
RAL/RA/IA/SJ/ SM/EG/NEG/NCM	Full series	HX-13D	HX-13N	HX-13P	HX-13R	
TBC/XBC/ VBC/LBC	Full series	HX-21D	HX-21N	HX-21P	HX-21R	
FVBC/EXSM/ EXSWM/SF/SFM	Full series	HX-31D	HX-31N	HX-31P	HX-31R	
FVBC/EXSM/ EXSWM/SF/SFM	Full series	-	-	-	HX-65R	

Item/ Model	Electronic type			Reed switch
	D	N	P	R
Wiring method	2-Wire type	3-Wire type		2-Wire type
Wire color	Black			Gray
Sensor type	Without contact			With contact
Operating voltage	10-28V DC	5-30V DC		5-240V AC/DC
Switching current	50mA max	200mA max		100mA max
Contact rating	1.4W max	6W max		10W max
Response sepeed	High frequency			Low frequency
Service life	Ultra long			Long
Shock	Almost no impact			Easy to damage
Sensing range	Almost using in all cylinders			Narrow range of sensing
Action range	4-5mm from switch on to off			7-10mm from switch on to off
Accuracy	Excellent			Ordinary

Note: According to above chart, please give priority to electronic type.

## HX-01 Magnet Switch



### How to Order?

HX	-	01	D	-	2M
Product code		Series NO.	Switch Type D: Two wire without contact switch N: NPN type P: PNP type R: Two wire reed switch		Wire length 1M:1M 2M:2M 5M:5M 10M:10M ..... QD8: QD8 Male connector QD12: QD12 Male connector

Note: The standard wire length of the quick connector is 0.15m. Other wire lengths cannot be ordered

### Dimension

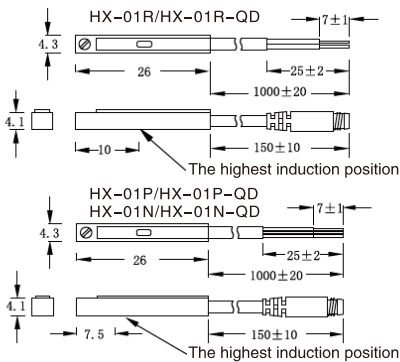

### Groove Dimension

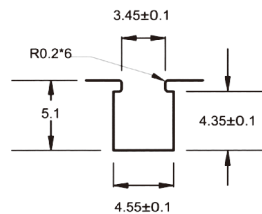

Suitable for cylinder:  
SD/SE/SHY/SHZ/ESWT

### M8/M12 male wiring diagram

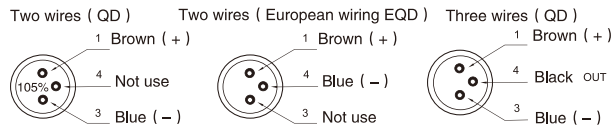

### Specifications

Type	HX-01D	HX-01N	HX-01P	HX-01R
Connect Diagram				
Parameter				
Wiring method	2-Wire Type	3-Wire Type		2-Wire Type
Switching logic		Electronic type N.O.		SPST Normally Open
Sensor type	None contact type	NPN type ( Input)	PNP type ( Output)	Reed switch
Operating voltage	10-28V DC	5-30V DC		5-240V DC/AC
Max. switching current	50mA max	200mA max.		100mA max.
Contact rating	1.4 W max	6W max.		10W max.
Current consumption	40 μA max @ 24V	8mA max @ 24V (Switch Active)		None
Voltage drop	2.8 V max.	1 V max. @ 200mA DC		2.5 V max.
Leakage current	90 μA max @ 28V	0.01mA max.		None
Indicator		Red LED		
Max. exchange frequency		1000Hz		200Hz
Temperature range		-10 - 70°C		
Shock		50G		30G
Vibration		9G		
Enclosure classification		IEC 529 IP67 (NEMA 6)		
Protection circuit	2, 4	3, 4		1
Cable	2.6Φ, 2C, Black color, oil resistance PVC	2.6Φ, 3C, Black color, oil resistance PVC		2.6Φ, 2C, Gray color, oil resistance PVC
Switch sensitive		40-750G		70G

## HX-07 Magnet Switch



### How to Order?

HX	-	07	D	-	2M
Product code		Series NO.	Switch Type D: Two wire without contact switch N: NPN type P: PNP type R: Two wire reed switch		Wire length 1M:1M 2M:2M 5M:5M 10M:10M ..... QD8: QD8 Male connector QD12: QD12 Male connector

Note: The standard wire length of the quick connector is 0.15m. Other wire lengths cannot be ordered

### Dimension

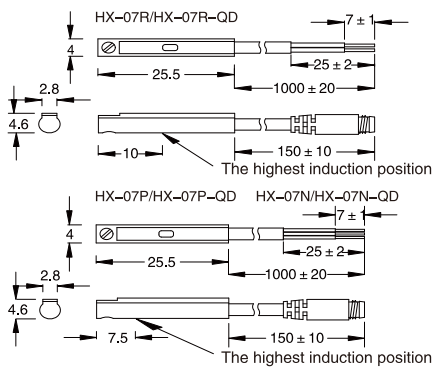

### Groove Dimension

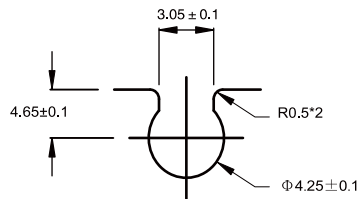

Suitable for cylinder:

- SQ/SQM/EU/EUK/
- EUM/EUP/SF/SFM/
- SQK/SG//EMQ/ELS/
- ELQ/EXH/ESWT
- \*SHY/SHZ (except  $\phi 10$ )

### M8/M12 male wiring diagram

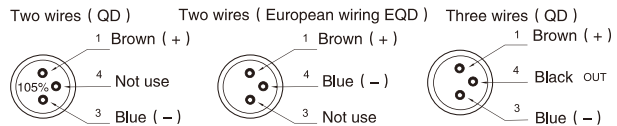

### Specifications

Type	HX-07D	HX-07N	HX-07P	HX-07R
Connect Diagram				
Parameter				
Wiring method	2-Wire Type	3-Wire Type		2-Wire Type
Switching logic		Electronic no contact type N.O.		SPST Normally Open
Sensor type	None contact type	NPN type ( Input )	PNP type ( Output )	Reed switch
Operating voltage	10-28V DC	5-30V DC		5-240V DC/AC
Max. switching current	50mA max	200mA max.		100mA max.
Contact rating	1.4 W max	6W max.		10W max.
Current consumption	40 $\mu$ A max @ 24V	8mA max @ 24V (Switch Active)		None
Voltage drop	2.8 V max.	1 V max. @ 200mA DC		2.5 V max.
Leakage current	90 $\mu$ A max @ 28V	0.01mA max.		None
Indicator		Red LED		
Max. exchange frequency		1000Hz		200Hz
Temperature range		-10 - 70°C		
Shock		50G		30G
Vibration		9G		
Enclosure classification		IEC 529 IP67 (NEMA 6)		
Protection circuit	2, 4	3, 4		1
Cable	2,6 $\phi$ , 2C, Black color, oil resistance PVC	2,6 $\phi$ , 3C, Black color, oil resistance PVC		2,6 $\phi$ , 2C, Gray color, oil resistance PVC
Switch sensitive		40-750G		70G

## HX-11 Magnet Switch



### How to Order?

HX	-	11	D	-	2M
Product code		Series NO.	Switch Type D: Two wire without contact switch N: NPN type P: PNP type R: Two wire reed switch		Wire length 1M:1M 2M:2M 5M:5M 10M:10M ..... QD8: QD8 Male connector QD12: QD12 Male connector Note: The standard wire length of the quick connector is 0.15m. Other wire lengths cannot be ordered

### Dimension

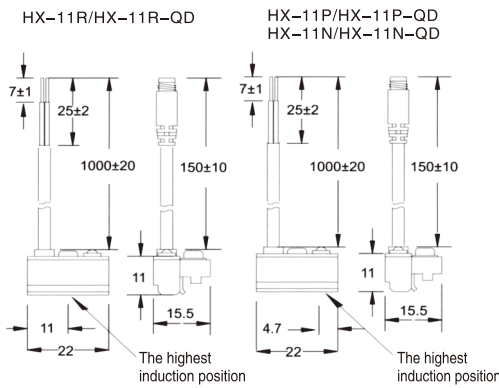

### Groove Dimension

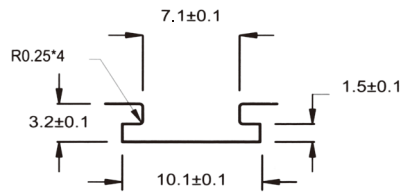

### M8/M12 male wiring diagram

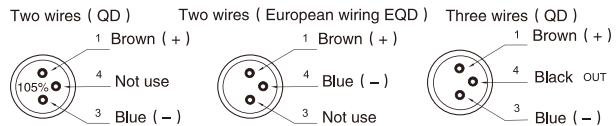

### Specifications

Type	HX-11D	HX-11N	HX-11P	HX-11R
Connect Diagram				
Parameter				
Wiring method	2-Wire Type	3-Wire Type		2-Wire Type
Switching logic		Electronic type N.O.		SPST Normally Open
Sensor type	None contact type	NPN type ( Input)	PNP type ( Output)	Reed switch
Operating voltage	10-28V DC	5-30V DC		5-240V DC/AC
Max. switching current	50mA max	200mA max.		100mA max.
Contact rating	1.4 W max	6W max.		10W max.
Current consumption	40 μA max @ 24V	20mA max @ 24V (Switch Active)		None
Voltage drop	2.8 V max.	1 V max. @ 200mA DC		2.5 V max.
Leakage current	90 μA max @ 28V	0.01mA max.		None
Indicator		Red LED		
Max. exchange frequency		1000Hz		200Hz
Temperature range		-10 - 70°C		
Shock		50G		30G
Vibration		9G		
Enclosure classification		IEC 529 IP67 (NEMA 6)		
Protection circuit	2, 4	3, 4		1
Cable	3.3Φ, 2C, Black color, oil resistance PVC	3.3Φ, 3C, Black color, oil resistance PVC		3.3Φ, 2C, Gray color, oil resistance PVC
Switch sensitive		40-750G		40-50G

## HX-13 Magnet Switch



### How to Order?

<b>HX</b>	<b>-</b>	<b>13</b>	<b>D</b>	<b>-</b>	<b>2M</b>	<b>-</b>	<b>A</b>	<b>-</b>	<b>20</b>																				
Product code		Series NO.	Switch Type D: Two wire without contact switch N: NPN type P: PNP type R: Two wire reed switch		Wirelength 1M:1M 2M:2M 5M:5M 10M:10M ..... QD8: QD8 Male connector QD12: QD12 Male connector		Bore material Blank: No binding belt A: Aluminum alloy barrel (with binding belt) S: Stainless steel barrel (with binding belt)		Bore code																				
									<table border="1"> <thead> <tr> <th>Bore material</th> <th>Bore code</th> </tr> </thead> <tbody> <tr><td rowspan="4">Aluminum alloy barrel</td><td>16: Bore16Φmm</td></tr> <tr><td>20: Bore20Φmm</td></tr> <tr><td>25: Bore25Φmm</td></tr> <tr><td>32: Bore32Φmm</td></tr> <tr><td rowspan="4">Stainless steel barrel</td><td>40: Bore40Φmm</td></tr> <tr><td>06: Bore06Φmm</td></tr> <tr><td>08: Bore08Φmm</td></tr> <tr><td>10: Bore10Φmm</td></tr> <tr><td rowspan="4"></td><td>12: Bore12Φmm</td></tr> <tr><td>16: Bore16Φmm</td></tr> <tr><td>20: Bore20Φmm</td></tr> <tr><td>25: Bore25Φmm</td></tr> <tr><td rowspan="2"></td><td>32: Bore32Φmm</td></tr> <tr><td>40: Bore40Φmm</td></tr> </tbody> </table>	Bore material	Bore code	Aluminum alloy barrel	16: Bore16Φmm	20: Bore20Φmm	25: Bore25Φmm	32: Bore32Φmm	Stainless steel barrel	40: Bore40Φmm	06: Bore06Φmm	08: Bore08Φmm	10: Bore10Φmm		12: Bore12Φmm	16: Bore16Φmm	20: Bore20Φmm	25: Bore25Φmm		32: Bore32Φmm	40: Bore40Φmm
Bore material	Bore code																												
Aluminum alloy barrel	16: Bore16Φmm																												
	20: Bore20Φmm																												
	25: Bore25Φmm																												
	32: Bore32Φmm																												
Stainless steel barrel	40: Bore40Φmm																												
	06: Bore06Φmm																												
	08: Bore08Φmm																												
	10: Bore10Φmm																												
	12: Bore12Φmm																												
	16: Bore16Φmm																												
	20: Bore20Φmm																												
	25: Bore25Φmm																												
	32: Bore32Φmm																												
	40: Bore40Φmm																												
Note: The standard wire length of the quick connector is 0.15m. Other wire lengths cannot be ordered																													

### Dimension

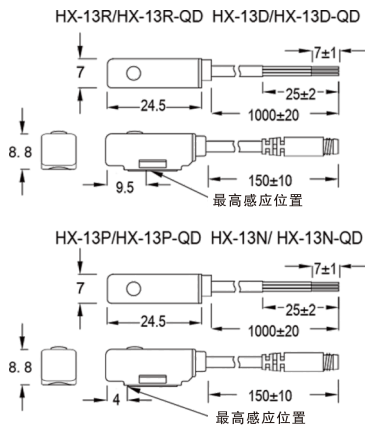

### Installation

Detailed mounting method refer to page 1.127-1.129

Suitable for cylinder:  
RAL/ RA/IA/SJ/  
SM/EG/NEG/NCM

### M8/M12 male wiring diagram

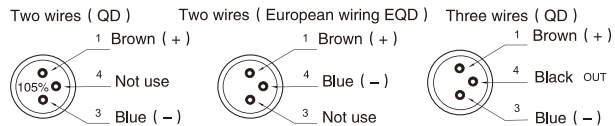

### Specifications

Type	HX-13D	HX-13N	HX-13P	HX-13R
Connect Diagram				
Parameter				
Wiring method	2-Wire Type	3-Wire Type		2-Wire Type
Switching logic		Electronic no contact type N.O.		SPST Normally Open
Sensor type	None contact type	NPN type ( Input)	PNP type ( Output)	Reed switch
Operating voltage	10-28V DC	5-30V DC		5-240V DC/AC
Max. switching current	50mA max	200mA max.		100mA max.
Contact rating	1.4 W max	6W max.		10W max.
Current consumption	40 μA max @ 24V	8mA max @ 24V (Switch Active)		None
Voltage drop	2.8 V max.	1 V max. @ 200mA DC		2.5 V max.
Leakage current	90 μA max @ 28V	0.01mA max.		None
Indicator		Red LED		
Max. exchange frequency		1000Hz		200Hz
Temperature range		-10 - 70°C		
Shock		50G		30G
Vibration		9G		
Enclosure classification		IEC 529 IP67 (NEMA 6)		
Protection circuit	2, 4	3, 4		1
Cable	3.2Φ, 2C, Black color, oil resistance PVC	3.2Φ, 3C, Black color, oil resistance PVC		3.2Φ, 2C, Black color, oil resistance PVC
Switch sensitive		45-750G		50G

## HX-21 Magnet Switch



### How to Order?

HX	-	21	D	-	2M
Product code		Series NO.	Switch Type D: Two wire without contact switch N: NPN type P: PNP type R: Two wire reed switch		Wire length 1M:1M 2M:2M 5M:5M 10M:10M ..... QD8: QD8 Male connector QD12: QD12 Male connector  Note: The standard wire length of the quick connector is 0.15m. Other wire lengths cannot be ordered

### Dimension

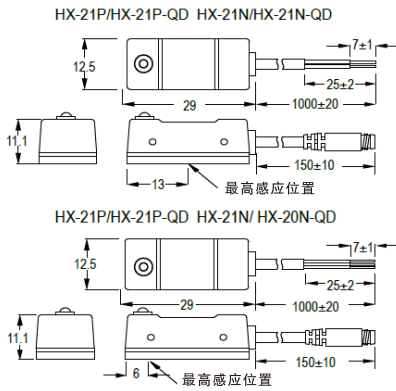

### Installation

Detailed mounting method refer to page [1.127-1.129](#)

Suitable for cylinder: TBC/XBC/VBC/LBC

### M8/M12 male wiring diagram

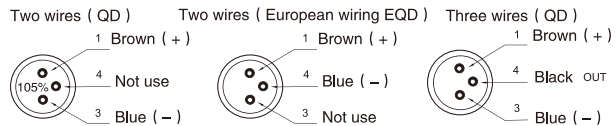

### Specifications

Type	HX-21D	HX-21N	HX-21P	HX-21R
Connect Diagram				
Parameter				
Wiring method	2-Wire Type	3-Wire Type		2-Wire Type
Switching logic		Electronic type N.O.		SPST Normally Open
Sensor type	None contact type	NPN type ( Input)	PNP type ( Output)	Reed switch
Operating voltage	5-30V DC	5-30V DC		5-240V DC/AC
Max. switching current	50mA max	200mA max.		100mA max.
Contact rating	1.4 W max	6W max.		10W max.
Current consumption	40 μA max @24V	20mA max @24V (Switch Active)		None
Voltage drop	2.8 V max.	1 V max. @200mA DC		2.5 V max.
Leakage current	90 μA max @28V	0.01mA max.		None
Indicator		Red LED		
Max. exchange frequency		1000Hz		200Hz
Temperature range		-10 - 70°C		
Shock		50G		30G
Vibration		9G		
Enclosure classification		IEC 529 IP67 (NEMA 6)		
Protection circuit	2, 4	3, 4		1
Cable	3.8Φ, 2C, Black color, oil resistance PVC	3.8Φ, 3C, Black color, oil resistance PVC		3.8Φ, 2C, Gray color, oil resistance PVC
Switch sensitive		40-750G		55-65G

## HX-29 Magnet Switch



### How to Order?

HX	-	29	D	-	2M
Product code		Series NO.	Switch Type D: Two wire without contact switch N: NPN type P: PNP type R: Two wire reed switch		Wirelength 1M:1M 2M:2M 5M:5M 10M:10M ..... QD8: QD8Male connector QD12: QD12Male connector  Note: The standard wire length of the quick connector is 0.15m. Other wire lengths cannot be ordered

### Dimension

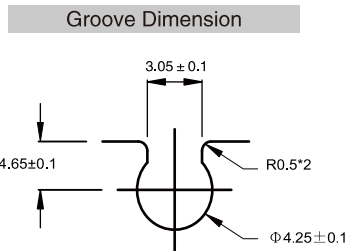
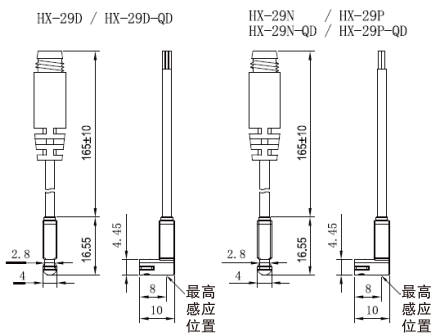

Suitable for cylinder:  
SQ/SQM/EU/EUK/  
EUM/EUP/SF/SFM/  
SQK/SG//EMQ/ELS/  
ELQ/EXH/ESWT  
\*SHY/SHZ(except Φ 10)

### M8/M12 male wiring diagram

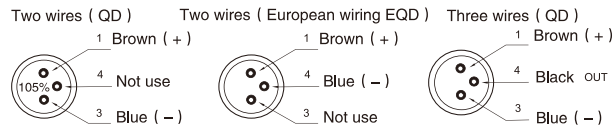

### Specifications

Type	HX-29D	HX-29N	HX-29P
Connect Diagram			
Parameter			
Wiring method	2-Wire Type	3-Wire Type	
Switching logic	Electronic no contact type N.O.		
Sensor type	None contact type	NPN type ( Input)	PNP type ( Output)
Operating voltage	10-28V DC	5-30V DC	
Max. switching current	50mA max	200mA max.	
Contact rating	1.4 W max	6W max.	
Current consumption	40 μAmax@24V	8mAmax@24V(Switch Active)	
Voltage drop	2.8 V max.	1 V max.@200mA DC	
Leakage current	90 μAmax@28V	0.01mA max.	
Indicator	Red LED		
Max. exchange frequency	1000Hz		
Temperature range	-10 - 70°C		
Shock	50G		
Vibration	9G		
Enclosure classification	IEC 529 IP67 (NEMA 6)		
Protection circuit	4	3、4	
Cable	2.6Φ,2C,Black color,oil resistance PVC	2.6Φ,3C,Black color,oil resistance PVC	
Switch sensitive	40-750G		

## HX-31 Magnet Switch



### How to Order?

<b>HX</b>	<b>-</b>	<b>31</b>	<b>D</b>	<b>-</b>	<b>2M</b>
Product code		Series NO.	Switch Type D: Two wire without contact switch N: NPN type P: PNP type R: Two wire reed switch		Wire length 1M:1M 2M:2M 5M:5M 10M:10M ..... QD8: QD8 Male connector QD12: QD12 Male connector Note: The standard wire length of the quick connector is 0.15m. Other wire lengths cannot be ordered

### Dimension

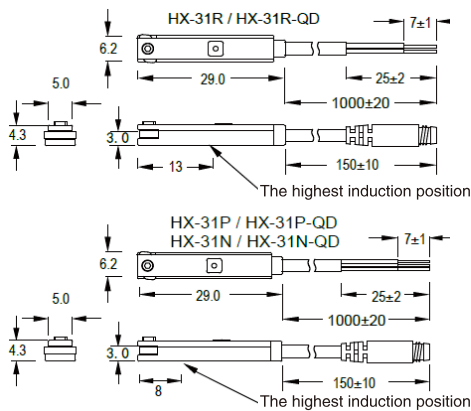

### Groove Dimension

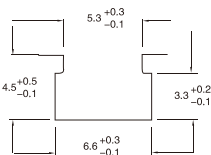

Suitable for cylinder:  
FVBC/EXSM/  
EXSWM/SF/SFM

### M8/M12 male wiring diagram

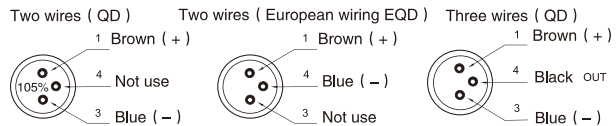

Type	HX-31D	HX-31N	HX-31P	HX-31R
Connect Diagram				
Parameter				
Wiring method	2-Wire Type	3-Wire Type		2-Wire Type
Switching logic		Electronic type N.O.		SPST Normally Open
Sensor type	None contact type	NPN type ( Input)	PNP type ( Output)	Reed switch
Operating voltage	10-28V DC	5-30V DC		5-240V DC/AC
Max. switching current	50mA max	200mA max.		100mA max.
Contact rating	1.4 W max	6W max.		10W max.
Current consumption	40 μA max @24V	14(N)/17(P)mA max (Switch Active)		None
Voltage drop	2.8 V max.	1 V max. @200mA DC		2.5 V max.
Leakage current	90 μA max @28V	0.01mA max.		None
Indicator		Red LED		
Max. exchange frequency		1000Hz		200Hz
Temperature range		-10 - 70°C		
Shock		50G		30G
Vibration		9G		
Enclosure classification		IEC 529 IP67 (NEMA 6)		
Protection circuit	2, 4	3, 4		1
Cable	2.9Φ, 2C, Black color, oil resistance PVC	2.9Φ, 3C, Black color, oil resistance PVC		2.9Φ, 2C, Gray color, oil resistance PVC
Switch sensitive		40-750G		40G

## HX-65 Magnet Switch



### How to Order?

HX	-	65	D	-	2M
Product code		Series NO.	Switch Type D: Two wire without contact switch N: NPN type P: PNP type R: Two wire reed switch		Wirelength 1M:1M 2M:2M 5M:5M 10M:10M ..... QD8: QD8 Male connector QD12: QD12 Male connector

Note: The standard wire length of the quick connector is 0.15m. Other wire lengths cannot be ordered

### Dimension

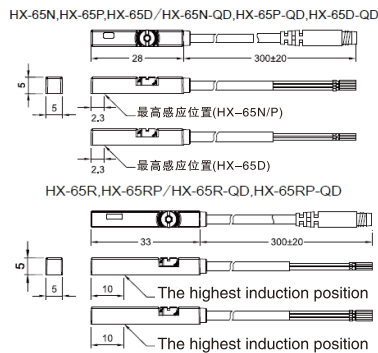

### Groove Dimension

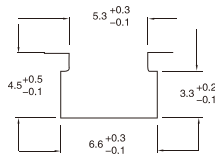

Suitable for cylinder:  
FVBC/EXSM/  
EXSWM/SF/SFM

### M8/M12 male wiring diagram

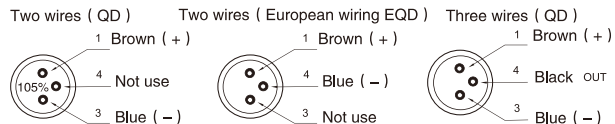

### Connect Diagram

Type	HX-65D	HX-65N	HX-65P	HX-65R
Connect Diagram				
Parameter				
Wiring method	2-Wire Type	3-Wire Type		2-Wire Type
Switching logic		Electronic no contact type N.O.		SPST Normally Open
Sensor type	None contact type	NPN type ( Input)	PNP type ( Output)	Reed switch
Operating voltage	10-28V DC	5-30V DC		5-240V DC/AC
Max. switching current	50mA max	200mA max.		100mA max.
Contact rating	1.4 W max	6W max.		10W max.
Current consumption	40 μAmax@24V	8mAmax@24V DC (Switch Active)		None
Voltage drop	2.8 V max.	1 V max.@200mA DC		2.5 V max.
Leakage current	90 μAmax@28V	0.01mA max.		None
Indicator		Red LED		
Max. exchange frequency		1000Hz		200Hz
Temperature range		-10 - 70°C		
Shock		50G		30G
Vibration		9G		
Enclosure classification		IEC 529 IP67 (NEMA 6)		
Protection circuit	2, 4	3, 4		1
Cable	2.6φ, 2C, Black color, oil resistance PVC	2.6φ, 3C, Black color, oil resistance PVC		2.6φ, 2C, Black color, oil resistance PVC
Switch sensitive		40-750G		70G

## IH/UH Bracket

### Dimension

	<p><b>IH series bracket</b> (VBC profile barrel)</p> <p>IH-32 IH-40 IH-50 IH-63 IH-80 IH-100 IH-125 IH-160 IH-200</p>
	<p><b>UH series bracket</b> (XBC profile barrel)</p> <p>UH-32 UH-40 UH-50 UH-63 UH-80 UH-100</p>

<p><b>IH-32</b></p> <p>Suitable for VBC cylinder bore <math>\Phi</math> 32</p>	<p><b>IH-40</b></p> <p>Suitable for VBC cylinder bore <math>\Phi</math> 40</p>	<p><b>IH-50</b></p> <p>Suitable for VBC cylinder bore <math>\Phi</math> 50</p>
<p><b>IH-63</b></p> <p>Suitable for VBC cylinder bore <math>\Phi</math> 63</p>	<p><b>IH-80</b></p> <p>Suitable for VBC cylinder bore <math>\Phi</math> 80</p>	<p><b>IH-100</b></p> <p>Suitable for VBC cylinder bore <math>\Phi</math> 100</p>
<p><b>IH-125</b></p> <p>Suitable for VBC cylinder bore <math>\Phi</math> 125</p>	<p><b>IH-160</b></p> <p>Suitable for VBC cylinder bore <math>\Phi</math> 160</p>	<p><b>IH-200</b></p> <p>Suitable for VBC cylinder bore <math>\Phi</math> 200</p>

<p><b>UH-32</b></p> <p>Suitable for XBC cylinder bore <math>\Phi</math> 32</p>	<p><b>UH-40</b></p> <p>Suitable for XBC cylinder bore <math>\Phi</math> 40</p>	<p><b>UH-50</b></p> <p>Suitable for XBC cylinder bore <math>\Phi</math> 50</p>
<p><b>UH-63</b></p> <p>Suitable for XBC cylinder bore <math>\Phi</math> 63</p>	<p><b>UH-80</b></p> <p>Suitable for XBC cylinder bore <math>\Phi</math> 80</p>	<p><b>UH-100</b></p> <p>Suitable for XBC cylinder bore <math>\Phi</math> 100</p>

## PM Bracket

### Dimension



PM series bracket (TBC, LBC Cylinder)  
PM-6 PM-8 PM-10 PM-12 PM-16

PM-6	PM-8	PM-10	PM-12	PM-16
Suitable for TBC32/40/50 LBC32/40 Diameter of tie-rod $\Phi 5 \sim \Phi 6$	Suitable for TBC63 LBC50/63 Diameter of tie-rod $\Phi 7 \sim \Phi 8$	Suitable for TBC80/100 LBC80/100 Diameter of tie-rod $\Phi 8.5 \sim \Phi 10$	Suitable for TBC125 LBC125 Diameter of tie-rod $\Phi 10.5 \sim \Phi 12$	Suitable for TBC160 LBC160/200 Diameter of tie-rod $\Phi 14 \sim \Phi 16$

## PAB

### Mounting Band

#### ◎ PAB series fixed steel belt (Fixed size for round body cylinder, HX-13 auto switch)

	<p><b>Step 1</b></p> <p>Put the magnetic switch in the steel belt.</p>	<p><b>Step 2</b></p> <p>Get around the steel belt and magnetic switch.</p>	<p><b>Step 3</b></p> <p>Insert the steel belt into the slot, adjust the release of the switch, tighten the screw on the steel belt.</p>	<p><b>Step 4</b></p> <p>After adjusting the position of magnetic switch, fixed steel belt</p>
	<p>PAB - S 2 0 Bore</p> <ul style="list-style-type: none"> <li>S: The Round Barrel Cylinder (stainless steel material) Applicable to bore: 06、08、10、12、16、20、25、32、40、50、63</li> <li>A: The Round Barrel Cylinder (alluminum alloy material) Applicable to bore: 16、20、25、32、40</li> </ul>			

Note: This steel belt cannot be used in EG series round cylinder

#### ◎ PAB-13 series mounting band (Universal for HX-13 auto switch)

	<p><b>PAB-13:</b> Suitable for Φ6 - Φ63</p>	<p><b>Step 1</b></p> <ol style="list-style-type: none"> <li>Loosen the screw on the steel belt first</li> <li>Make sure that three to four circle of thread at the bottom of the screw is still in the nut</li> </ol>	<p><b>Step 2</b></p> <ol style="list-style-type: none"> <li>Get the steel belt through the hole at the bottom of HX-13</li> <li>Put the screw head into the slot of the clip as below picture, then tighten the steel belt</li> <li>Mark on the round hole of the nearest PIN of the belt</li> </ol>	<p><b>Step 3</b></p> <ol style="list-style-type: none"> <li>Loosen the steel belt</li> <li>Mark the hole as below picture, and cut the belt on the second hole away from the mark hole</li> </ol>	<p><b>Step 4</b></p> <ol style="list-style-type: none"> <li>Put the belt that's just been cut down into the slot hole of the steel belt</li> <li>Put the chuck PIN onto the mark hole</li> <li>Use the thumb to press down the steel belt along the chuck, bending the belt</li> <li>Assemble the switch and the cylinder as below picture, then adjust the position of magnet switch, lock the screw, then you could fix it.</li> </ol>
					<p><b>⚠ Attention!</b></p> <p>Please don't lock the screw with too much force, otherwise might cause damage on magnet switch or cylinder.</p>

